

## Bus Navigation System Using Gsm-Gps Technology

Reshma.M\*, Saravanakumar.G\*\*, Gandhiraj.S\*\*\*

\* (Department Of Electrical And Electronics Engineering, Sasurie College Of Engineering, Vijayamangalam.)

\*\* (Department Of Electrical And Electronics Engineering, Sasurie College Of Engineering, Vijayamangalam)

\*\*\* (Assistant Professor, Department Of Electrical And Electronics Engineering, Sasurie College Of Engineering, Vijayamangalam)

### ABSTRACT

The main problem in the current scenario is the tracking of an organization buses while moving on a highway is a crucial task. A person patiently waiting for the bus may need to enquire about the position of current location of the bus. Mobile phones based bus tracking system provides a solution to this problem which helps anyone to know the location of the bus without calling or disturbing the person travelling in that bus. It also consists of accident detection system in which the vibration sensor has been used in order to detect the occurrence of the accident and once if the accidents occur then the message will be given to the system. It will track the location of the bus where it met with accident and immediately delivers the message about the accident to the emergency services such as ambulance and concerned people without time delay. The speed monitoring and controlling system in the bus will help to detect and take control actions on the speed of the bus when it get enters in the safe zones such as schools, hospitals, educational institutions for that purpose the RFID transmission and receiving system employed.

**Keywords**—GSM, GPS, RFID, Vibration sensor, Ultrasonic sensor

### I. INTRODUCTION

In these urban life transportations is very common. A lot of mishappenings occur on the road every day. Therefore the need of security and monitoring is developed. To resolve such problems, a system is developed using GPS and GSM technologies. The various problems that we face in day to day life are,

Standing for bus on the respective bus stops without knowing the arrival and departure time of the bus, for respective stops accurately and also buses available for in that route. If any accident happens the affected people have to wait for period of time to receive the emergency helps from the accident occurred. The sudden stopping of the bus due to the scarcity of the fuel in the fuel tank.

This proposed system developed for overcome and resolve the above faults. The system introduced in this paper was specially designed for Educational Institutions buses.

There are many paper presented work on the bus tracking system when the new technology got improved a small review of those papers, [9] In this proposed system in order to track vehicle the web application was developed by using the C language and contains it NMEA protocols with GGA (Global Positioning System with Fixed Data) and GLL (Geographic Position Latitude/Longitude). The GSM module will send the co-ordinates of the

Vehicle position as SMS to the user mobile number. And that mobile number has to be included in that software when it was developing. That SMS

will fed to the web application as decoded (such as in ddm.mmm) form by GPS receiver then the system will shows the position of that vehicle in the monitor screen. In order to run this application the WAMP server software must. Thus monitoring system will run only in the PC with internet connection.

[3] This system was developed with the modules such as In-Bus module and Bus-Stand module. The Bus-Stand module will send the status of the bus stand to the In-Bus module. Depending upon the report the driver will takes the decision. Thus status such as, number of passengers in bus stop and inside the bus, ETA (Estimated time of Arrival) and ETD (Estimated Time of Departure) are calculated by using IR sensors. This system mainly focused on the public transportation.

[1] Thus proposed system will help to detect the position of a failure bus. In order to provide the help in minimum time and also it will provide the short path and route through the GSM messaging service. Thus project majorly deals with the getting help as soon as possible from mishappenings occurred. But thus system was maintained and carried out by only management authority with a good graphical interface.

[2] This system is an attempt of providing the better help and detection of accident. This system majorly deals with the two primary functions such as to detect the accident and automatically generate and send an SMS containing location of the accident to the emergency services and to detect the

flames and smoke in the vehicle. Noticeably this system developed for the cars only.

## II. BUS NAVIGATION SYSTEM USING GSM-GPS TECHNOLOGY SYSTEM STRUCTURE

In the process of system design the following steps are followed with proper way of the work,

### 2.1 BLOCK DIAGRAM

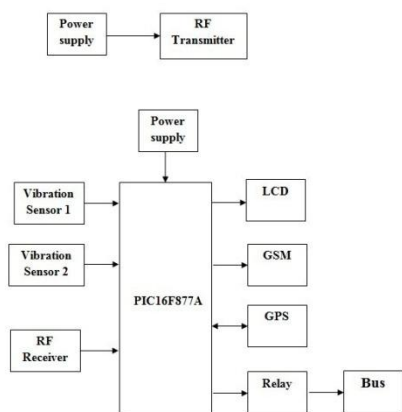

Fig 1: Block diagram of the system

### 2.2 Block Diagram Description

#### 2.2.1 Transmitter Section

The proposed system consists of PIC16F877A, Power supply, Vibration sensor, LCD, GSM Modem and GPS. The user must carry an android phone with them in order to know the status of the bus such as location of bus, its arrival time, departure time, the bus able for the particular route etc.,

The vibration sensor in the bus is used to detect occurrence of any accident and once if accident occurs then the signal will be given to the microcontroller and the microcontroller will send the message to the concerned emergency services through the GSM Modem and the GPS is used to track the location such as latitude and longitude where the accident had been taken place. The ultrasonic sensor is used to indicate the level of the fuel in digital format. The RF Transmitter will be kept in the bus and once reaches the school zone then its speed will be automatically get reduced.

#### 2.2.2 Microcontroller Pic16f877a

PIC 16F877 is a 40-pin 8-Bit CMOS FLASH Microcontroller from Microchip. The core architecture is high-performance RISC CPU with only 35 single word1 instructions. Since it follows

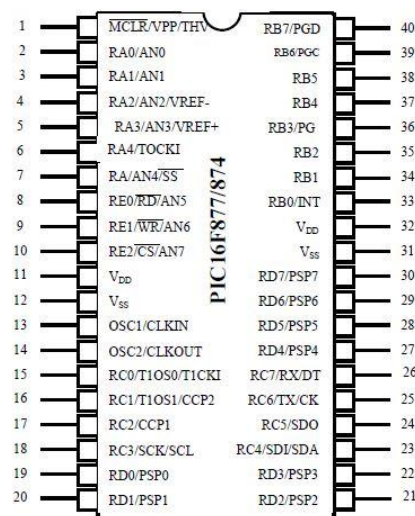

Fig 2: Pin Diagram of PIC16F877A

the RISC architecture, all single cycle instructions take only one instruction cycle except for program branches which take two cycles. 16F877 comes with 3 operating speeds with 4, 8, or 20 MHz clock input. Since each instruction cycle takes four operating clock cycles, each instruction takes 0.2 micro seconds when 20MHz oscillator is used.

It has two types of internal memories: program memory and data memory. Program memory is provided by 8K words (or 8K\*14 bits) of FLASH Memory, and data memory has two sources. One type of data memory is a 368-byte RAM (random access memory) and the other is 256-byte EEPROM (Electrically erasable programmable ROM). The core feature includes interrupt capability up to 14 sources, power saving SLEEP mode, and single 5V In-Circuit Serial Programming (ICSP) capability. The sink/source current, which indicates a driving power from I/O port, is high with 25mA. Power consumption is less than 2mA in 5V operating condition.

#### 2.2.3 VIBRATION SENSOR

The vibration sensor are used to sense any accident occurrence once if any signal is send to microcontroller then the microcontroller will send the location of the accident spot to the emergency services by getting the GPS value using GPS modem via message through GSM modem. The vibration / shock sensor detects shock intensity caused by sudden knocks or hits and continuous vibration due to any obstacles on bus. The shock levels and monitoring durations can be set for each individual sensor, enabling a user-defined profile for up to tolerance level.

#### 2.2.4 Speed Monitoring And Controlling

The RF receiver in the bus when receives any signal from the RF transmitter fixed in the school or hospital zone then the signal will be provided to the microcontroller then automatically the speed of the bus will get reduced.

#### 2.2.5 Receiver Section

The android mobile application is the receiver section of our entire system. This application makes our proposed system much more efficient than the already developed systems. With this application, the smart phone users can see the track position of the bus with internet connection.

This system has Global Positioning System (GPS) which will receive the co-ordinates from the satellites among other critical information. The system is microcontroller based that consists of a GPS and GSM along with the interfacing of all other sensing units which are all located in various places in that bus. The system is not limited to find the location of the target but also calculates the distance travelled between two stops and all other sensing functions through the smart phones.

### III. RESULTS

The position, arrival time and departure time of the bus are exactly known. The intimations regarding accidents are sent to the emergency services and concerned people with location of the accident. Speed monitoring and controlling actions are done automatically in safe zones.

### IV. CONCLUSION

This research provides passengers with information such as exact location of the bus and approximate arrival time of the bus. The advantages of the proposed system is that it provides real time updated information, reduces passenger waiting time, usage of android phones enables ease of usage and is user friendly and also the system has easy implementation and low maintenance cost.

### REFERENCES

- [1]. Prof. Devidas S. Thosar, Rishikesh K. Zade, Onkar V. B. Abrekar, Priyanka R. Chaudhari, "Bus Tracking and Bus Failure Detection Systems Using GPS" International Research Journal of Engineering and Technology Vol.2, Issue.7, October 2015.
- [2]. Pratiksha R. Shetgaonkar, Vijakumar Naik Pawar, Rajesh Gauns "Proposed Model for the Smart Accident Detection System for Smart Vehicles Using Arduino board, Smart Sensors, GPS and GSM" International Journal of Emerging Trends & Technology in Computer Science Vol.4, Issue.4, July-August 2015.
- [3]. Shita M. Dharrao, Vijay D. Choudhary, Kantilal P. Rane "Intelligent Bus Stand Monitoring and Control Using Combination of GSM, GPS & IR Sensors" International Journal of Innovative Research in Science Engineering and Technology Vol. 4, Issue 7, July 2015.
- [4]. Vigneshwaran K., Sumithra S., "An Intelligent Tracking System Based on GSM and GPS Using Smartphones" International Journal of Advanced Research in Electrical, Electronics and Instrumentation Engineering Vol.4, Issue.5, May 2015.
- [5]. Ankita Pendole, Ajay Shingare "GPS Supported City Bus Tracking & Smart Ticketing System" 978-1-4673-7910-6/04 2015 IEEE
- [6]. Avinash Kumar A., Singaravelan U., Premkumar T.V., Gnanaprakash K "Digital Fuel Level Indicator in Two-Wheeler Along with Distance to Zero Indicator" IOSR Journal of Mechanical and Civil Engineering Vol.11, Issue.2, May-April 2014.
- [7]. Rose marry John, Finky Francis, Joe Neelankavil "Smart Public Transport System" International Conference on Embedded Systems 2014, 978-1-4799-5026-3/14 2014 IEEE.
- [8]. Nimmy James, Aparna C, Teena P John "Alcohol Detection System" International Journal of Research in Computer and Communication Technology Vol.3, Issue.1, January 2014.
- [9]. Pankaj Verma, J.S Bhatia "Design And Development Of GPS-GSM Based Tracking System With Google Map Based Monitoring" International Journal Of Computer Science Engineering and Applications Vol.3, No.3, June 2013.
- [10]. K.P.Kamble, "Smart Vehicle Tracking System" International Journal of Distributed and Parallel Systems Vol.3, No.4, July 2012.