

Solar Cookers with Thermal Energy Storage Systems: A Review

Jaiswal Narayan Pravinchandra*

*Department of Mechanical Engineering, Faculty of Technology and Engineering, The M S University of Baroda, Gujarat, India,

ABSTRACT

Solar cooking technology has gained significant attention as a sustainable alternative to conventional cooking methods, particularly in developing regions where biomass and fossil fuels dominate energy consumption. These traditional methods contribute to environmental degradation, deforestation, and indoor air pollution, posing serious health and ecological concerns. Solar cookers utilize abundant solar radiation to generate heat for cooking, offering a clean, renewable, and cost-effective solution. This review examines different types of solar cookers, including box-type, parabolic, and indirect systems, along with their thermal performance and operational characteristics. A major limitation of solar cookers is their dependence on sunlight, restricting their use to daytime. To overcome this limitation, thermal energy storage (TES) systems have been integrated using sensible and latent heat storage materials. Among these, phase change materials (PCMs) demonstrate superior performance due to their high energy storage density and nearly constant heat release during phase transition. Recent advancements highlight improved efficiency through hybrid storage systems and optimized material compositions. Advanced designs such as twin-chamber cookers and steam-based systems further enhance performance and scalability. Despite these developments, challenges such as cost and weather dependency remain. Efficient TES integration is therefore crucial for improving reliability and promoting large-scale adoption.

Keywords - Box-type solar cooker, Hybrid heat storage, Off-sunshine cooking, Parabolic solar cooker, Phase change materials (PCM) Solar cooking, Thermal energy storage (TES)

Date of Submission: 01-05-2026

Date of acceptance: 09-05-2026

I. INTRODUCTION

Energy consumption for cooking constitutes a significant portion of the total household energy demand, particularly in developing countries where traditional fuels such as firewood, agricultural residues, and fossil fuels are predominantly used. These conventional cooking methods not only contribute to environmental degradation through deforestation and greenhouse gas emissions but also pose severe health risks due to indoor air pollution [3], [4]. According to various studies, a large percentage of rural households still depend on biomass fuels, leading to inefficient energy utilization and adverse socio-economic impacts [3]. Therefore, there is an urgent need to develop sustainable, clean, and cost-effective cooking technologies.

Solar cooking technology has emerged as a promising solution to address these challenges by utilizing renewable solar energy, which is abundant, free, and environmentally friendly. Solar cookers

convert solar radiation into thermal energy for cooking purposes, thereby eliminating the need for conventional fuels and reducing carbon emissions [4]. The adoption of solar cooking systems can significantly contribute to energy conservation, environmental protection, and improved public health. Moreover, solar cookers are particularly suitable for regions with high solar insolation, such as India and other tropical countries, where solar energy availability is consistent throughout the year [4].

Over the past few decades, extensive research has been conducted to develop and improve various types of solar cookers. Based on the mode of heat transfer and design configuration, solar cookers are broadly classified into direct and indirect types. Direct solar cookers, such as box-type, panel-type, and parabolic cookers, utilize solar radiation directly for cooking by concentrating or trapping heat within a confined space. Among these, box-type solar cookers are widely used due to their simplicity, low cost, and ease of operation. However, they generally

operate at moderate temperatures and require longer cooking times [2], [4].

On the other hand, concentrating solar cookers, such as parabolic dish and parabolic trough cookers, are capable of achieving higher temperatures suitable for frying and baking applications. These cookers use reflective surfaces to focus solar radiation onto a focal point, resulting in higher thermal efficiency. However, they require continuous solar tracking and careful handling due to safety concerns [2]. Indirect solar cookers represent another advanced category, where heat is transferred to the cooking vessel using a heat transfer fluid. These systems provide enhanced safety and flexibility, allowing cooking at locations away from direct sunlight [1], [2].

Despite the advantages of solar cooking technology, one of the major limitations is its dependence on solar radiation, which restricts its operation to daytime and clear weather conditions. This limitation significantly affects the reliability and user acceptance of solar cookers. To overcome this drawback, researchers have focused on integrating thermal energy storage (TES) systems into solar cookers. TES systems store excess thermal energy during peak sunshine hours and release it during off-sunshine periods, enabling cooking in the evening or even at night [5], [9].

Thermal energy storage systems can be broadly categorized into sensible heat storage and latent heat storage. Sensible heat storage materials, such as sand, water, oil, and pebbles, store energy by increasing their temperature. Although these materials are inexpensive and readily available, they require large volumes due to their low energy storage density, making the system bulky and less efficient [8], [9]. In contrast, latent heat storage systems use phase change materials (PCMs) that store and release energy during phase transitions (solid-liquid). PCMs offer higher energy storage density and nearly constant temperature during heat release, making them highly suitable for solar cooking applications [4].

Recent advancements in solar cooking technology have focused on improving the performance of TES systems through the use of hybrid storage materials and optimized system design. Studies have demonstrated that combining sensible and latent heat storage materials can

enhance heat retention and improve overall efficiency [11]. For instance, integrating PCM with materials like sand or metal particles can improve thermal conductivity and heat transfer characteristics, leading to better cooking performance during off-sunshine hours [11].

Furthermore, innovative designs such as twin-chamber solar cookers and steam-based indirect cooking systems have been developed to enhance efficiency and scalability. Twin-chamber designs allow simultaneous cooking of multiple food items without significant heat loss, making them suitable for community-level applications [10]. Similarly, steam-based solar cooking systems utilize heat transfer through steam to achieve high temperatures, enabling applications such as baking and large-scale cooking [1]. These advanced designs demonstrate the potential of solar cooking technology to replace conventional cooking systems in both domestic and commercial settings.

In addition to technological advancements, performance evaluation of solar cookers has also gained significant attention. Parameters such as thermal efficiency, cooking power, figures of merit (F1 and F2), and exergy efficiency are commonly used to assess the performance of solar cookers [3]. These performance indicators help in comparing different designs and identifying areas for improvement. Optimization of design parameters, such as absorber plate area, insulation thickness, and reflector geometry, plays a crucial role in enhancing the efficiency of solar cookers [3], [7].

Although considerable progress has been made in the development of solar cookers, several challenges still hinder their widespread adoption. These include high initial cost, intermittent availability of solar radiation, lack of awareness, and limitations in thermal energy storage technologies. Addressing these challenges requires continued research and development efforts, focusing on cost reduction, material innovation, and system integration.

This review paper aims to provide a comprehensive overview of solar cooking technologies with a particular focus on thermal energy storage systems. It examines different types of solar cookers, various TES materials and configurations, and recent advancements in design and performance optimization. The paper also

highlights the challenges and future prospects of solar cooking technology, emphasizing the importance of integrating efficient TES systems to enhance reliability and promote large-scale adoption.

II. EXPERIMENTAL SET UP AND METHODOLOGY

All headings from the Introduction to Acknowledgements are numbered sequentially using 1, 2, 3, etc. Subheadings

Tesfy et al [1], presents a solar thermal Injera baking setup using a parabolic dish concentrator (2.54 m² aperture) that focuses sunlight onto a receiver. A closed-loop system with a stainless-steel pipe and coiled heat exchanger circulates water, producing high-pressure steam (~250 °C) via natural boiling–condensation. This steam transfers heat to the baking stove for indirect cooking. The setup includes valves, pressure relief system, thermocouples, and manual/auto tracking, enabling efficient heat transport with minimal losses.

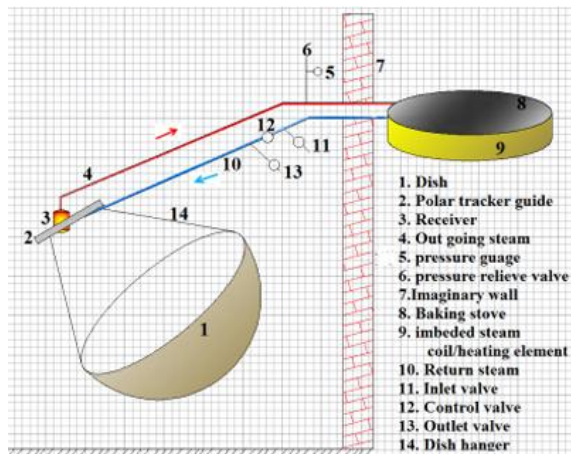

Fig 1. Polar mounted parabolic dish concentrator^[1]

Anilkumar et al [3], presents a **box-type solar cooker setup** with a rectangular insulated steel box, double-glazed glass cover, aluminium absorber plate, and an external reflector. Sensible heat storage materials (iron grits, sand, brick powder, charcoal) are placed beneath the absorber to retain heat. Methodology involves **design using heat loss and energy balance equations (via MATLAB)**, followed by fabrication and experimental tests such

as stagnation, load (sensible heat), and heat retention tests, along with evaluation of thermal efficiency and performance indicators (F1, F2).

Table 1. Thermo-Physical Properties of Heat Storage material ^[3]

Properties	Materials			
	Sand	Iron grits	Brick	Charcoal
Density (kg/m ³)	1515	1550	1920	450
Specific heat (J/kg K)	800	460	835	709

Anilkumar et al [4], uses a polar-mounted parabolic dish solar concentrator with a fixed receiver and tracking system to focus solar energy and generate pressurized steam in a closed-loop pipeline, which transfers heat to the Injera baking stove. Methodology involves system design, theoretical heat-loss modeling, and experimental testing under no-load and load conditions. Temperature data is recorded using thermocouples, and performance is evaluated through stagnation temperature, heating time, and actual baking trials under varying solar conditions.



Fig 2. Solar box cooker with encapsulated PCM ^[4]

Saini et al [5], uses a parabolic solar collector coupled with a thermal energy storage unit. Experiments were conducted during sunshine and off-sunshine hours by circulating heat transfer fluid. Temperatures at key points were measured to evaluate cooking performance, heat retention, and efficiency, comparing system behavior with and without stored thermal energy.

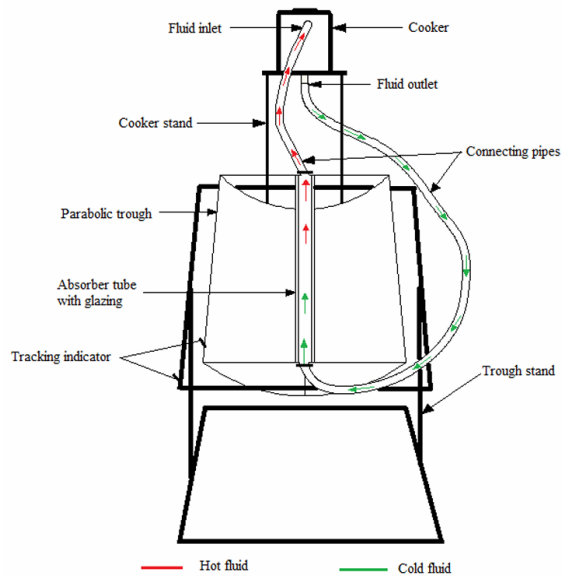

Fig 3. Schematic diagram of solar cooker based on parabolic trough collector with thermal storage unit [5]

Saxena et al [6], demonstrates solar box cooker integrated with low-cost thermal storage (sand-carbon mixture) and reflectors. Experiments included stagnation and load tests. Methodology involved measuring temperatures, solar input, and cooking performance, while evaluating thermal efficiency, heat loss, cooking power, and figures of merit under real outdoor conditions.



Fig 4. Schematic diagram of solar cooker based on parabolic trough collector with thermal storage unit [6]

Sekhon et al [10], presents a twin-chamber community solar cooker consisting of two insulated cooking chambers connected to a solar concentrator/collector system. The setup includes reflectors, absorber surfaces, and heat transfer pathways for uniform heating. Methodology involves thermal modeling using energy balance equations and experimental validation by measuring temperatures, solar radiation, and cooking performance. Parameters such as heat distribution, efficiency, and cooking capacity are analyzed under varying solar conditions to evaluate system effectiveness for large-scale cooking applications.

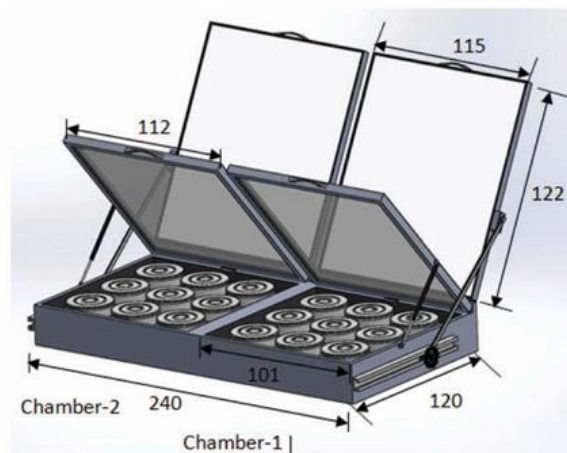

Fig 5(a) Isometric view of TCCS cooker [10]



Fig 5(b) Pictorial view of the developed twin-chamber community scale solar cooker [10]

III. RESULTS AND DISCUSSION

Theoretically the solar stove is expected to be competent with electric stove to favor energy switching. However, certain factors like intermittent nature of solar radiation, stove insulation, stove heating element and stove size affects its

performance and are considered while developing the theoretical model shown in Fig 6.

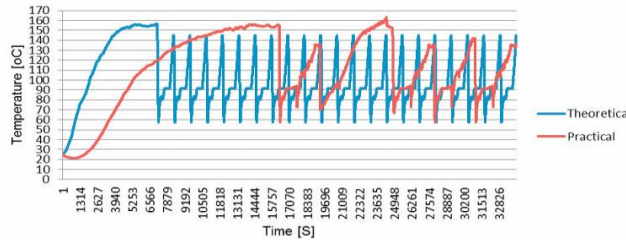

Fig. 6 Theoretical and experimental comparisons of solar stove^[1]

In different cases of water as a heat transfer fluid, it can be seen that the energy stored by PCM during charging process was in the range of 264.6kJ to 332.5kJ. Whereas, the energy stored by PCM in different cases of thermal oil as heat transfer fluid laid in the range of 401.1kJ to 445.9kJ. Overall energy stored by PCM was nearly 1.45 times more using thermal oil as heat transfer fluid as compared to energy stored using water as heat transfer fluid as shown in figure 7.

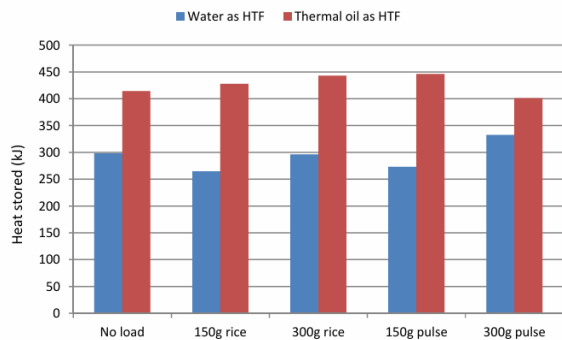

Fig. 7 Heat stored by PCM in different cases^[5]

Plot showing the variation of the collector instantaneous efficiency with time is given in figure 8.

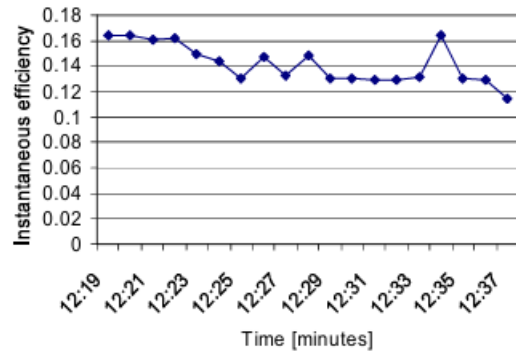

Fig. 8 Variation of instantaneous efficiency^[7]

Table 2 shows the temperature profile of solar cooker with 200gm sand as TES. It contains initial temperature when the power supply was switched on, highest temperature after 90 minutes and final temperature after 240 minutes when the final temperature show the heat retained capacity of sand for different input power viz. 12W, 30W and 42W.

Table Heat storage capacity for 200 gm sand^[8]

Time (minute)	T _{12W} (°C)	T _{30W} (°C)	T ₄₂ (°C)
0	31	34	31
90	111	197	245
180	50	65	75
240	37	41	46

Following table shows various important parameter for **Twin-chamber community solar (TCCS) cooker** with respect to time.

Table Thermal efficiency performance parameters of Twin-chamber community solar (TCCS) cooker at each hour of the day^[10]

Hour of day (3600 sec)	Heat absorbed (q_{ab})	Heat loss (q_l)	Useful heat gain (q_u)	Thermal efficiency η (%)
09:30-10:30	2.802	0.847	1.576	45.04
10:30-11:30	3.216	1.809	1.006	25.03
11:30-12:30	3.361	2.279	0.744	17.73
12:30-01:30	3.216	2.537	0.460	11.44
01:30-02:30	2.803	2.343	0.313	8.95
02:30-03:30	2.168	1.902	0.189	6.98
03:30-04:30	1.424	1.416	0.006	0.32

The experiment was conducted with inner space filled with PCM and outer space filled with sand and the results are shown in figure 9.

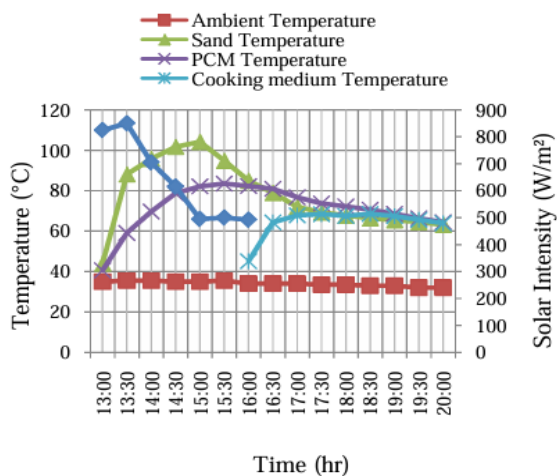

Fig 9 Variation of temperature and solar radiation intensity with time in case of solar cooker with inner space filled with PCM and outer space filled with sand^[11]

In second case the experiment was conducted with inner space filled with PCM and outer space filled with iron balls and the results are shown in figure 10.

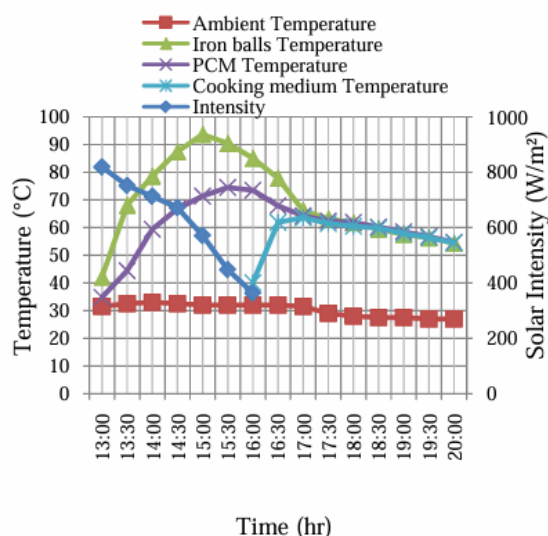

Fig 10 Variation of temperature and solar radiation intensity with time in case of solar cooker with inner space filled with PCM and outer space filled with iron balls^[11]

IV. CONCLUSION

Solar cooking technology has demonstrated significant potential as a sustainable and environmentally friendly alternative to conventional cooking methods, particularly in regions with high solar energy availability. The reviewed studies

highlight that various solar cooker designs, including box-type, parabolic, and indirect systems, offer distinct advantages in terms of cost, efficiency, and applicability [2], [4]. Among these, concentrating systems such as parabolic cookers achieve higher temperatures and improved thermal efficiency, making them suitable for a wider range of cooking applications [2], [7].

A major advancement in solar cooking technology is the integration of thermal energy storage (TES) systems, which addresses the key limitation of dependence on sunlight. The use of phase change materials (PCMs) has proven particularly effective due to their high energy storage density and ability to maintain nearly constant temperatures during heat release [4], [5]. Hybrid storage systems combining sensible and latent heat materials further enhance performance and extend cooking capability into off-sunshine hours [11].

Innovative designs such as twin-chamber cookers and steam-based systems have also shown improved efficiency and scalability for community-level applications [1], [10]. However, challenges such as high initial cost, intermittent solar availability, and material limitations persist. Overall, continued research on TES materials and system optimization is essential for improving reliability and promoting widespread adoption of solar cooking technologies.

Acknowledgements

An acknowledgement section may be presented after the conclusion, if desired.

REFERENCES

This heading is not assigned a number.

A reference list **MUST** be included using the following information as a guide. Only *cited* text references are included. Each reference is referred to in the text by a number enclosed in a square bracket (i.e., [3]). References **must be numbered and ordered according to where they are first mentioned in the paper**, NOT alphabetically.

REFERENCES

- [1]. A. H. Tesfay, M. B. Kahsay and O. J. Nydal, "Design and development of solar thermal Injera baking: Steam based direct baking," *Energy Procedia*, vol. 57, pp. 2946–2955, 2014.

- [2]. M. E. V. da Silva, L. L. P. Santana, R. D. B. Alves and K. Schwarzer, "Comparative study of two solar cookers: Parabolic reflector and flat plate collector indirect heating," *RIO 5 - World Climate & Energy Event*, Brazil, 2005.
- [3]. B. C. Anilkumar, R. Maniyeri and S. Anish, "Design, fabrication and performance assessment of a solar cooker with optimum composition of heat storage materials," *Environmental Science and Pollution Research*, 2020.
- [4]. B. C. Anilkumar and R. Maniyeri, "Design of thermal energy storage system for solar cooker: A review," *Sādhanā*, vol. 50, 2025.
- [5]. G. Saini, H. Singh, K. Saini and A. Yadav, "Experimental investigation of solar cooker during sunshine and off-sunshine hours using thermal energy storage unit based on parabolic trough collector," *International Journal of Ambient Energy*, 2015.
- [6]. A. Saxena and M. Karakilcik, "Performance evaluation of a solar cooker with low cost heat storage material," *International Journal of Sustainable and Green Energy*, 2017.
- [7]. S. I. Gilani et al., "Performance of parabolic trough collector for solar thermal applications," 2013.
- [8]. S. Joshi, "Performance of sand as heat storage material in solar cooker," *Journal of Environmental Research and Development*, 2015.
- [9]. P. Saini, V. Sharma, C. Singh and S. Singh, "Solar cookers for off-sunshine cooking," *Journal of Academia and Industrial Research*, vol. 3, no. 9, pp. 438–439, 2015.
- [10]. M. Sekhon and V. P. Sethi, "Thermal modeling and analysis of novel twin-chamber community solar cooker," *International Journal of Green Energy*, 2018.
- [11]. V. Yadav and A. Yadav, "Thermal performance evaluation of solar cooker integrated with dual heat storage unit for evening cooking," *Journal of Basic and Applied Engineering Research*, vol. 2, no. 4, pp. 235–239