

Buckling behavior of aluminum plate with circular and elliptical shapes of central cutout

Eng. Ahmed Khaled Mohamed Khaled

Buckling behavior of aluminum plate with circular and elliptical shapes of central cutout

Abstract

The present work performs mechanical buckling analyses and experimental investigation on square plates with central cutout with (circular and elliptical) shape and with different size under uniaxial compressive loading, clamped from the loaded sides and free from others. The plates were mostly used in aircraft structures, rocket and automobiles is aluminum alloy (Al-2024 T₃) because it has a high strength to weight ratio. The determination of critical buckling load of metallic plate is an important factor in determining the structural stability, which consider the best examination for buckling behavior. Experimental investigation was carried out on square plates by using strain gages. The experimental results for buckling load were compared with analytical results by using finite element structure analysis technique (F.E.M) i.e. using (ANSYS) software. Results have been presented that the square plates with circular and elliptical cutouts decrease in buckling strengths as the cutout sizes were increased.

Keywords: Buckling, Aluminum, Al-2024T3 plate, Cut-outs holes, Finite Element Method, ANSYS.

Date of Submission: 01-03-2024

Date of acceptance: 09-03-2024

I. Introduction:

The structural plates play a significant role in supporting essential components, such as aerospace vehicles, satellites, and drones, among others. These plates often contain central cutouts to accommodate various necessities, such as regions

reserved for electrical systems, millimeter-wave systems, or hydraulic systems, or for the passage of pipes that transport fluids from the tank to the engine or for the ventilation of the engine [1], as shown in Figure (1).

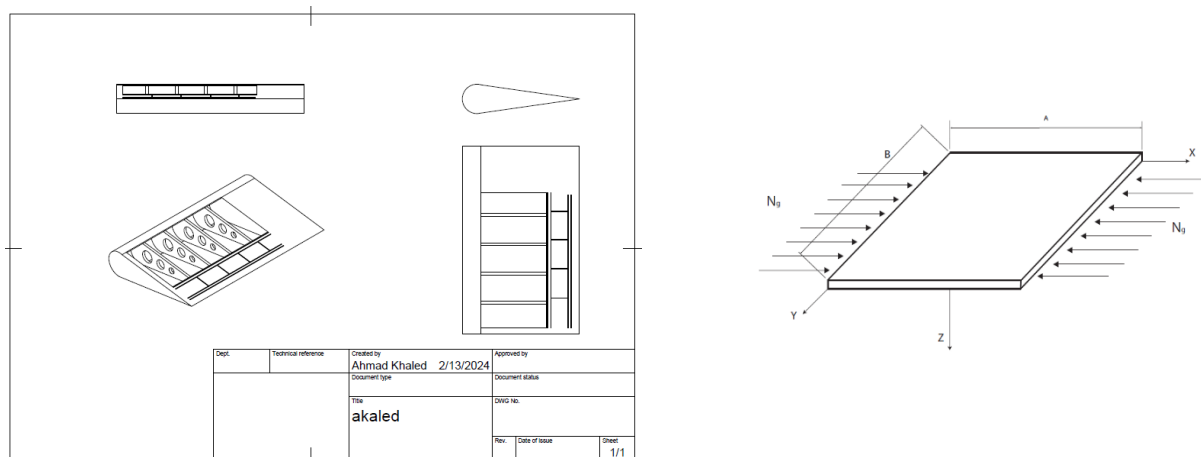

Fig (1) Illustrate the use of bracket plate in plane wing [3]

The design of these cutouts aims to reduce the weight of aerospace vehicles or drones, minimize the weight of the plate for practical purposes. For instance, the cutouts are required for air ducts and intakes or outlets for hydraulic

systems. Additionally, they are used for maintenance purposes for internal components, and they are employed in rib webs to provide lightweight reinforcement [2].

Therefore, the presence and arrangement of these openings can lead to improved system performance, which contributes to the stability of the structure body and reduces the overall weight, resulting in significant attention from researchers in recent years.

There are various studies related to this topic conducted by researchers [1990 Nemeth] [4]. These studies examine the behavior of buckling and after buckling for an aluminum alloy plate (6061-T₆) with square and rectangular shapes under different loading conditions, particularly focusing on central cutouts with various shapes.

The effects of different cutout shapes, such as circular, square, and elliptical, under applied pressure were investigated, and it was found that the stiffness and stress concentration of the plate are affected by the size of the cutout. For the plate with circular and square cutouts, the stress concentration increases with an increase in the size of the cutout. On the other hand, the elliptical-shaped cutouts showed a decrease in stress concentration compared to the circular and square ones, which indicates a better load distribution.

Furthermore, the results showed that square and rectangular plates with elliptical-shaped cutouts have a higher structural efficiency compared to plates with other shapes when subjected to loading and unloading conditions.

A study [5] was conducted on the buckling behavior of square and rectangular plates with central cutouts under uniaxial compressive loads. The plates were made of aluminum alloy (AL-2024 T₃) and analyzed using the finite element method (ANSYS). The results showed that square plates with circular and square cutouts exhibited a decrease in buckling resistance, while rectangular plates showed an increase in critical buckling load as the distance between the cutout and the plate edges increased.

Furthermore, it was observed that the buckling resistance of square plates with square cutouts decreased as the distance between the cutout and the plate edges increased. On the other hand, the buckling resistance of rectangular plates increased with an increase in the distance between the cutout and the plate edges. It was also found that the critical buckling load for square plates with square cutouts was larger than that for plates with circular cutouts, and this difference was more pronounced for larger cutout sizes.

In a study conducted by Jain [2004] [1], the use of constrained elements was employed to investigate the response of square laminated plates with cutouts to external loading. It was found that

buckling behavior of the plate containing multiple layers, as well as the presence of cutouts, can be significantly influenced by the arrangement of these elements.

Specifically, the study examined the buckling response of laminated ply-cross structures under external loading applied to both square and elliptical-shaped cutouts. The elements were strategically placed to enhance the plate's buckling resistance. The results indicated that the elliptical-shaped cutout, when properly arranged, can bear more load than the square-shaped cutout under the same applied external load conditions, especially when the plate edges are simply supported.

Additionally, (Ghannadpour 2006) [2] investigated the buckling of composite laminated plates with cross-ply Laminated) arrangements under external loading applied to both square and elliptical-shaped cutouts. The study demonstrated that, when properly designed, the elliptical-shaped cutout can enhance the plate's resistance to applied external loads more effectively than the square-shaped cutout, particularly when the plate edges are simply supported.

In a study conducted by (Komur 2010) [6] the buckling behavior of a composite plate made of glass-woven polyester, with multiple layers, was investigated under external loading applied to both square and elliptical-shaped cutouts. The elements were arranged at different angles using constrained techniques.

The results indicated that buckling response varied with an increase in the elliptical-shaped cutout's aspect ratio (c/a) when the major axis was equal to ($0.5 a$) times the minor axis. The buckling behavior gradually increased as the aspect ratio of the elliptical-shaped cutout increased, with the major axis aligned with the applied load. Additionally, increasing the inclination angle of the elliptical-shaped cutout (0° - 90°) resulted in different buckling behavior.

Furthermore, it was observed that the buckling resistance of the composite plate increased as the major axis diameter of the elliptical-shaped cutout deviated from the buckling resistance of the plate without a cutout. This behavior was influenced by the inclination angle of the major axis, highlighting the effect of the flexural behavior of the plate under external loading conditions.

In a study conducted by (Ganesan 2011) [7], the buckling behavior of symmetrically layered and laminated plates with centrally located cutouts was examined. The plates were simply supported along their opposite edges. The study investigated the effect of different sizes and shapes (rectangular,

square, and elliptical) of the central cutout on the plate's buckling response.

It was observed that the presence of a cutout reduced the buckling resistance of the plate due to stress concentration around the cutout and the reduction in the material's cross-sectional area. The effect of stress concentration was more pronounced in the case of square-shaped cutouts, while the effect of material removal increased with the distance between the cutout and the plate edges.

The results indicated that the buckling behavior varied with different shapes and sizes of the cutout. Plates with rectangular cutouts exhibited higher buckling resistance compared to other types of cutouts. Additionally, Kumar [2010] [8] demonstrated that both layered and simply supported plates exhibited higher buckling resistance and better load-bearing capacity compared to plates with fixed edges, regardless of the cutout shape and size.

1-1 :Research purpose

The main objective of the current research is to study the behavior of the elastic buckling of square-shaped metal sheets containing central openings of various shapes and sizes or without, manufactured from aluminum alloys AL-2024T₃ (square-shaped aluminum alloys containing central openings of circular and elliptical shapes and various sizes). The study aims to investigate the influence of both the dimensions and the shape of the opening on the buckling characteristics (critical buckling load) of these sheets. Practical results of the buckling load are compared with analytical results using the finite element technique. The analysis includes determining the ideal shape of the opening as well as the first critical mode of buckling, involving finding the value of the critical buckling load and its corresponding shape. Additionally, the study explores the impact of changes in the shape and size of the opening under firmly fixed conditions on the edges of the sheet exposed to axial compressive loads.

II. Practical implementation

2-1 : The used models

The utilized aluminum plate is made of (AL-2024T₃) alloy with a thickness of 1.2 mm. It is a significant commercial alloy widely used in various fields such as aerospace due to its high

strength-to-weight ratio. Additionally, it finds applications in the manufacturing of truck wheels and various fastening products for different assemblies. Typically, these alloys consist of multiple elements, with two main alloying elements primarily added to them. The use of a ternary phase diagram is common for calculating the required thermal treatments. For example, considering the AL-2024 alloy, it consists of approximately 4% copper and 1% magnesium, along with minor quantities of manganese, silicon, iron, and chromium

2-2:Model Preparation:

Square plates with distinct features were used as specimens for displacement and stress concentration analyses under specific loading and boundary conditions. The plate has a length and width ($a = b = 100$ mm) and a constant thickness of ($t = 1.2$ mm). The ratio of length to width is unity, and the plate's curvature corresponds to the curvature of the support. The plates were pierced using a punching machine, where the diameter of the central free holes (d) varied from (5 mm) to (50 mm) for ten specimens, with a constant difference of (5 mm) between consecutive diameters (a-2). As for the square plates with elliptical holes, one of the fixed hole dimensions (d_2) is (20 mm), while the other dimension (d_1) varied from (5 mm) to (50 mm) for ten specimens, with a constant (5 mm) difference between consecutive diameters. Regarding the first elliptical hole, its major axis (d_1) varied while the minor axis (d_2) remained constant, resulting in a stress change on the major axis and thus affecting the plate's width (b-2). The second elliptical hole underwent a variation in its major axis (d_1) while the minor axis (d_2) remained constant, similarly influencing the stress distribution on the major axis and the plate's width (c-2). Plasma cutting machine was used to cut square plates with elliptical central holes, followed by drawing the plate models with elliptical holes using AutoCAD_2010 software. These models were then imported into the plasma cutting machine's computer, providing instructions for cutting the specimens accordingly. The software also adjusted the external boundary conditions of the plate to its actual dimensions, considering the elliptical hole's length ($a = 120$ mm).

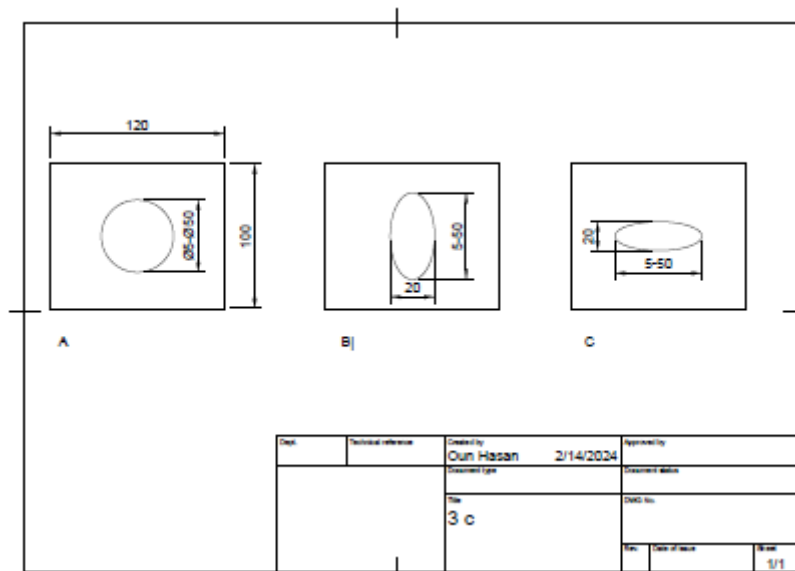

ALL dimension in mm

2-2 Model Inspection

Due to the various parameters affecting the buckling analysis process, experimental approaches have become essential for understanding the buckling behavior of square or rectangular plates containing openings. Analyzing buckling becomes complex in the case of plates containing openings because these openings create local stress concentrations, resulting in irregular stress distribution in these perforated plates. Therefore, bidirectional strain gauges were used strategically on the sides near the openings to measure strains in both directions. Compression tests were conducted on twenty-four plates containing openings with different shapes (rectangular and elliptical) and sizes to determine the influence of plate thickness and opening size on the buckling behavior of these plates. A material testing device (WP 300) with a capacity of 20 kN was used for practical experiments to measure the critical compressive stress applied uniaxially and the corresponding plate deflections. The plates were securely fixed to the testing machine, ensuring that the length of the plate was parallel to the direction of loading, and compression was applied uniformly. During testing, the lower platen moved upward due to hydraulic action, while the upper platen remained stationary. Displacement gauges were used to measure lateral deflections,

with their probes positioned at the midpoint of the plate length, as shown in the diagram (3).

Recording the applied compressive stress and lateral deflections with increasing load allows determining the critical buckling stress. The deformations occurring on the side of the openings were also recorded using strain gauges. An increase in applied load leads to a significant increase in lateral deflection, while the compressive stress remains relatively constant (the increase in stress follows the increase in critical buckling load). Therefore, recording the applied stress and lateral deflections with increasing load helps in understanding the lateral deflection behavior, with deflections ranging between 0.1-0.2 mm until a certain point where lateral deflection stabilizes, typically between 4.3-4.7 mm, with most readings equaling 4.3 mm. Analyzing the load causing buckling is facilitated by plotting the lateral deflection against the applied compressive stress. Thus, determining the critical buckling stress for plates containing openings practically and accurately relies on identifying a specific point from the plotted curve between the applied load and lateral deflection. This point is determined based on observing the lateral deflection behavior with increasing loads; as lateral deflection deviates from its previous values, we identify this point as the critical buckling stress [1].



Fig (3) : Laboratory Tensile Testing Machine capacity (20 KN) used for practical buckling test.

III. Theoretical discussion

Theoretical Aspect: In solid structures like beams and columns, as well as in plates, buckling occurs not only due to lateral deflections under concentrated loads but also due to buckling phenomena [9]. In reality, the buckling phenomenon manifests as a flexural instability phenomenon in rigid structures such as plates and solid beams. Since buckling stresses follow thermal stresses in solid materials, leading to flexural instability in the structure, they represent the elastic limit of the material [5]. When compressive loads are applied to a plate, stresses increase uniformly along the length and width of the plate. However, the plate becomes locally unstable in the central area due to bending resulting from plate curvature. Buckling of the plate occurs in two opposite directions, depending on the different boundary conditions surrounding the plate. The fundamental difference between a plate and a beam lies in the nature of the buckling phenomenon. While a beam cannot resist lateral deflection without additional support, the free edge of the plate also experiences flexural instability.

As for the plate, it experiences direct compression from the edges; hence, it resists compressive stresses without undergoing lateral deflection under the first buckling load [9]. In this context, analytical methods were also employed to determine the critical buckling load. Since buckling analysis becomes complex in plates containing openings due to their susceptibility to stress concentration and resulting irregular stress distribution in the plate, approximate analytical methods were used to determine the critical buckling load. Researchers initially attempted theoretical approximation methods; however, they eventually resorted to conventional analysis methods using finite element theory due to its high computational efficiency for complex structures. Thus, the use of finite element theory proved to be an effective tool in buckling analysis. Both conventional analysis methods and the ANSYS 13 software were used as standard tools for determining the critical buckling loads of aluminum plates with various central openings, shapes, and sizes

IV. Results and discussion

The critical buckling load for the plate containing openings was determined practically by plotting the curve between the applied load and lateral deflection. These values were then compared with those obtained using the finite element method (F.E) with the ANSYS software. It is important to understand the buckling behavior of perforated plates compared to solid plates. The characteristics of buckling for a non-perforated plate differ significantly from those of a perforated plate. In a non-perforated plate, the stress field is uniform under pure buckling, and buckling occurs according to symmetry and continuity along the plate's width. However, the stress field in a perforated plate is non-uniform due to the presence of sharp edges around the perforations. Therefore, theoretical analysis methods are not applicable, which necessitates the use of practical methods or finite element analysis (FEA) in this case.

4-1 : Effect of Circular Opening on Buckling Load .

The experimental values of the applied compressive load and lateral deflection for the

plates were recorded, and these practical values were compared with those obtained from the finite element method (F.E) as shown in Table (1). It is observed from this table that the buckling load increases proportionally with the increase in the diameter ratio of the circular opening. As the buckling load increases, the diameter ratio of the central circular opening affects the plate's buckling behavior due to stress concentration around the opening and the reduction in the effective cross-sectional area of the plate. This reduction is due to the decrease in the cross-sectional area away from the center of the plate, resulting in a decrease in the moment of inertia and a decrease in the critical buckling load leading to the instability of the structure. Buckling phenomena, as well as post-buckling behavior, are significantly influenced by the size of the opening. The practical and analytical values of the buckling load show a proportion of (35%) and (32.7%) respectively, for a range of diameter ratios (d/b) from (0) to (0.5). However, if the edges are not exposed to concentrated loads, the buckling load increases with an increase in the diameter ratio of the central circular opening, which is considered an exceptional case

Table (1): Comparison between Experimental and Analytical Values of Critical Buckling Load for Plates with Central Circular Openings.

d/b	Buckling force (KN)		Difference Ratio
	Practical values	Analytical Values	
0.00	6.3	6.2382	0.981
0.05	6.3	6.3346	-0.549
0.10	6.1	6.1576	-0.944
0.15	5.9	5.9672	-1.139
0.20	5.7	5.7534	-0.936
0.25	5.5	5.6183	-2.151
0.30	5.3	5.4024	-1.932
0.35	5.1	5.1433	-0.849
0.40	4.8	4.8485	-1.01
0.45	4.5	4.5668	-1.484
0.50	4.1	4.1917	-2.236

4-2: The Effect of the Elliptical Opening, whose diameter (d1) varies perpendicular to the applied load, on the Buckling Load Value.

The practical values of the compressive load and lateral deflection of the plates were recorded, along with the practical values of the critical buckling load under thermal buckling, and the results obtained were compared using the Finite Element method (F.E), as shown in Table (2). It is observed from this table that the thermal buckling

load varies proportionally with the increase in the diameter of the elliptical opening (d1). The thermal buckling load gradually increases with the increase in the diameter of the central elliptical opening (d1) of the plate, resulting from the concentration of stresses around the opening and the effect of the reduced material quantity in the plate. This is reflected in the reduction of the area of the section about the centroid of the plate (about the midpoint of the plate) and the consequent reduction in the

self-strain, which leads to a decrease in the stability of the structure. The practical and analytical values of the thermal buckling load show a ratio of

(28.5%) and (27.7%) respectively, for an increase in the ratio of (d1/b) from (0) to (0.5).

Table (2): Comparison between Practical and Analytical Values of the Free Thermal Buckling Load for the Plate Containing Elliptical Openings, where the diameter (d1) varies perpendicular to the applied load

d/b	Buckling force (KN)		Difference Ratio
	Practical values	Analytical Values	
0.00	6.3	6.2382	0.981
0.05	6.2	6.2609	-0.982
0.10	6.0	6.0787	-1.311
0.15	5.9	5.9672	-1.267
0.20	5.7	5.9748	-0.936
0.25	5.6	5.6013	-0.023
0.30	5.4	5.4289	-0.535
0.35	5.2	5.2047	-0.09
0.40	4.9	4.9798	-1.628
0.45	4.7	4.7358	-0.761
0.50	4.5	4.5105	-0.233

4-3- The effect of the elliptical opening, with its diameter varying (1d), in the direction of the applied load on the value of the buckling load.

The plate containing elliptical openings was examined, where the diameter (d1) of the openings changed perpendicular to the applied load, while their other diameter (d2) remained constant, with a value of (20 mm). The practical values of the compressive load with lateral deflection for the plates and the practical values of the buckling load were recorded, and the results were compared with those obtained using the finite element method (F.E), as shown in Table (3). It is observed from this table that the buckling load value for the plate containing elliptical openings with a diameter (d1) of 5 mm is generally higher than that for the plate without openings. This is because the stress concentration for the elliptical openings in this case occurs perpendicular to the applied load, due to the sharp change in the opening's edge (sharp edges of the opening). Table (3) also shows that the practical values of the free

thermal buckling load are almost equal for most of the central elliptical openings (d1), as their compressive load arrangements are ordered after the digit four (the device used to examine the buckling state in our study relies on arrangements after the fourth digit). Therefore, the analytical values of the free thermal buckling load indicate a gradual increase with the increase in the diameter of the central elliptical opening (d1) for the plate, resulting from the concentration of stresses around the opening and the effect of the removed material from the plate. Its effect is greater than the stress concentration because its value is proportional to its square. As the size of the opening (the amount of removed material from the plate) increases, the plate's buckling load decreases. This applies to both plates containing elliptical openings with a diameter (d1) equal to 25 mm and 40 mm. The practical and analytical values of the free thermal buckling load are compared by a ratio of (12.7%) and (9.7%) respectively, for an increase in the ratio (d1/b) from (0) to (0.5)

Table (3): Comparison between Practical and Analytical Values of Free Thermal Buckling Load for the Plate Containing Elliptical Openings with Varying Diameter (d1) Perpendicular to the Applied Load.

d/b	Buckling force (KN)		Difference Ratio
	Practical values	Analytical Values	
0.00	6.3	6.2382	0.981
0.05	5.9	5.9313	-0.53
0.10	5.8	5.8674	-1.162

0.15	5.8	5.8400	-0.689
0.20	5.7	5.7534	-0.936
0.25	5.7	5.7828	-1.452
0.30	5.7	5.5714	-0.901
0.35	5.7	5.7248	-0.435
0.40	5.6	5.7275	-2.276
0.45	5.6	5.6925	-01.651
0.50	5.5	5.6535	-2.791

4-4: Comparison of the Buckling Load Results for Plates Containing Circular or Elliptical Holes in Both Types.

The influence of buckling and post-buckling behavior significantly affects the hole size, where there is a decrease in the post-buckling resistance for the perforated plate until the plate continues to bear additional load after buckling, unlike the solid plates due to the presence of hot edges of the holes. A comparison was made between centrally located and elliptical holes

regarding critical buckling resistance (buckling load). The overall results obtained for plates with circular holes and their corresponding results for plates with elliptical holes are shown in Table 4. Consequently, it is concluded that the observed phenomena are due to the equalization of their sizes according to the following equation:

$$\frac{\pi d^2}{4} t = \frac{\pi d_1 d_2}{4} t \Rightarrow \frac{d}{b} = \frac{\sqrt{d_1 d_2}}{b}$$

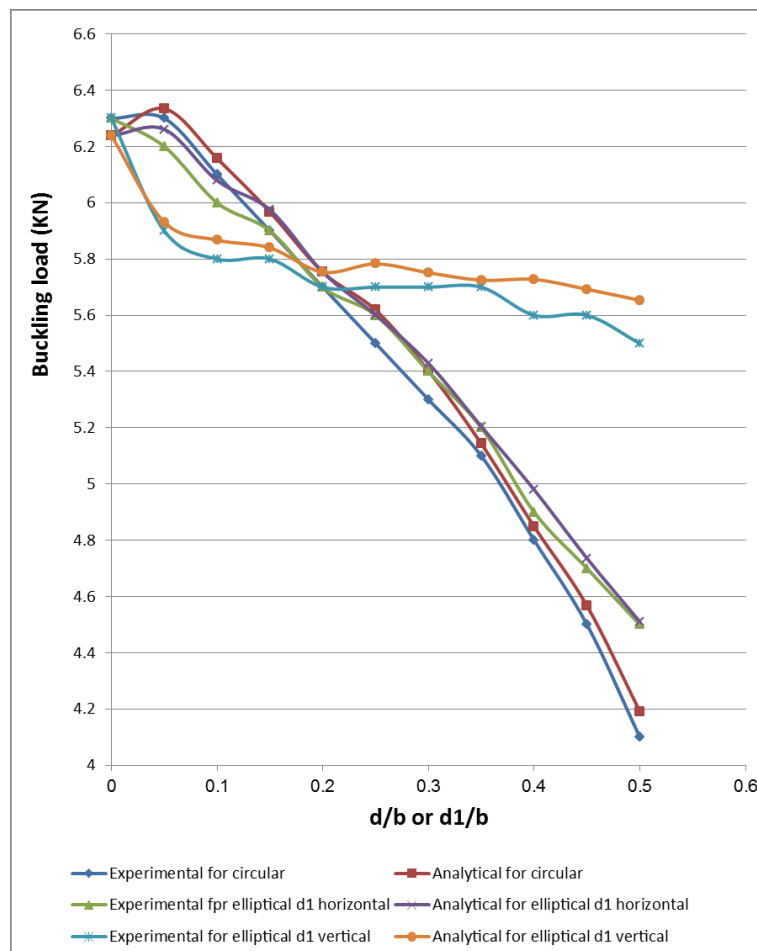
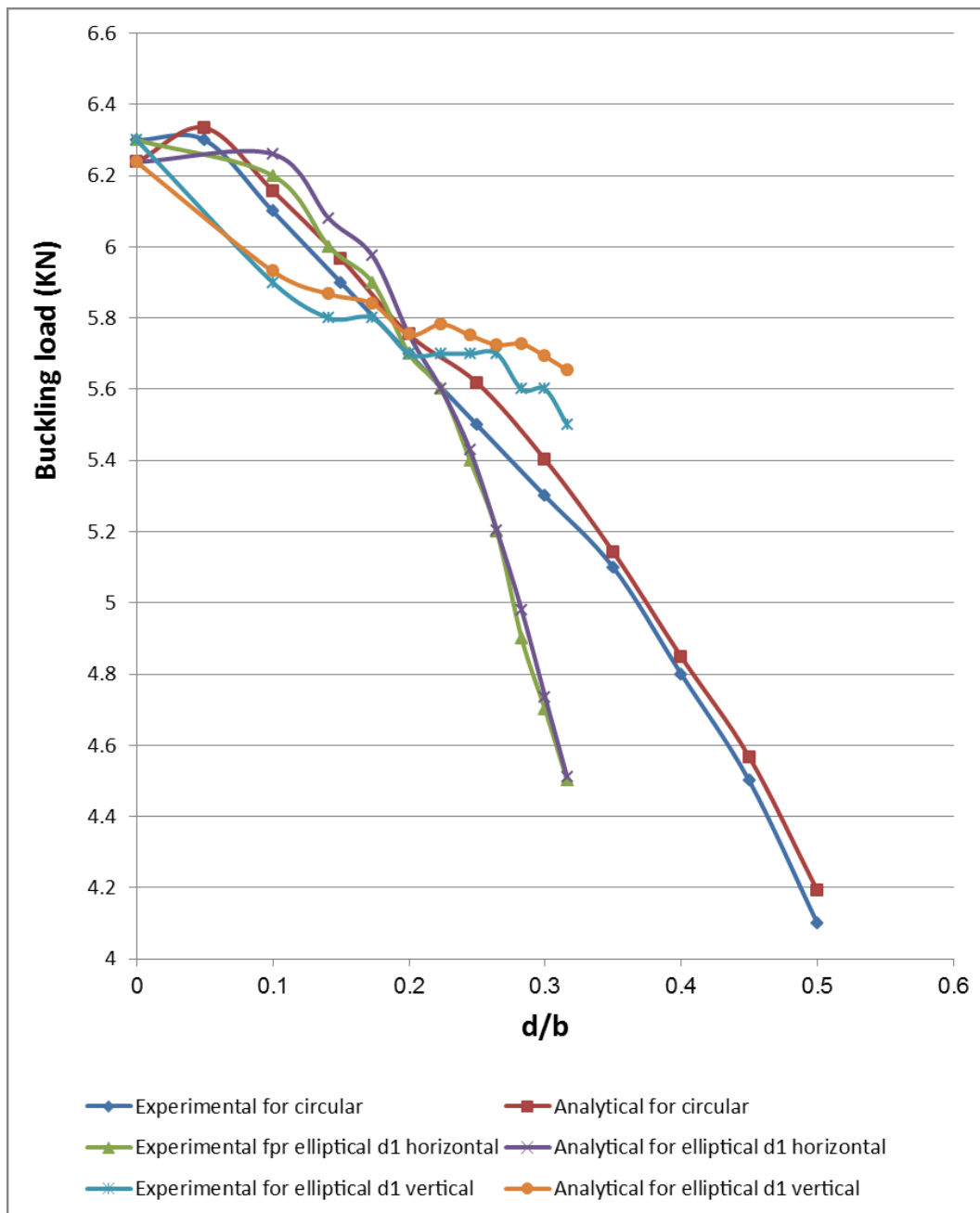

Fig (4) The relationship between the experimental and analytical values of the critical buckling load in relation to the ratio of the cutout width to the plate width

Tables (1), (2), (3), and similarly Table (4) illustrate that the buckling load of hot buckling plates with free holes is greater than the buckling load of cold buckling plates. Additionally, when the hole size is small (less than 20 mm), because the volume of the remaining material is greater than the volume of the removed material from the perforated plate on the free hole side, this affects the condition of the perforated plate on the free hole side. Consequently, when the volume of the removed material is proportional to the load-bearing capacity of the plate, the plate's load-bearing capacity decreases. As for the observation from Table (5), it shows that the perforated plates on the elliptical holes with varying orientation due to the applied load (parallel to the minor axis or parallel to the major axis) have a higher load-bearing capacity than other types of holes due to the increase in the volume of removed material. This results in a proportional decrease in the load-bearing capacity of the plate, as shown in Table (6)

and also observed in the case of perforated plates with circular holes. This is because the volume of removed material from the perforated plate with circular holes is smaller than that from the perforated plate with elliptical holes, resulting in a higher load-bearing capacity for the former. Perforated plates with elliptical holes oriented parallel to the major axis have a slightly higher load-bearing capacity, approximately by 5%, than the load-bearing capacity of hot buckling plates with either free or cold holes. This is due to the fact that the concentration of stresses on elliptical holes with a major axis orientation affects the condition of the free-hole plates differently than that of cold-hole plates. The sharp change in the geometry of these holes leads to an increase in stress concentration, thereby increasing the load-bearing capacity of the plate. As stress increases, the load-bearing capacity of the plates increases because stress increases at the holes, affecting the overall buckling condition.



With regard to ensuring the stability of the buckling load for plates containing openings, it is noted that the elliptical openings, especially those with a smooth boundary, have the highest resistance to applied load.

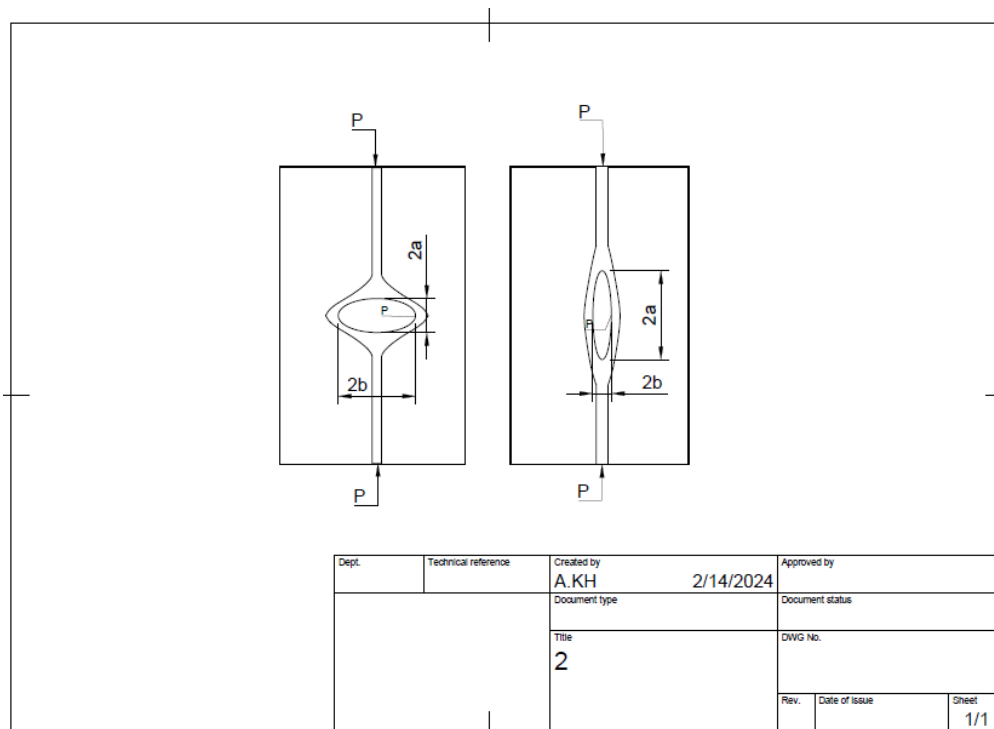

Fig: (6) Stress concentration around elliptical openings.

V. Conclusion

Upon conducting a comprehensive examination of the behavior of plates subjected to thermal buckling, both aluminum alloys AL-2024T₃, square in shape, with central perforations of various sizes, and rectangular perforations with different aspect ratios, were considered. This study investigated the effect of hole dimensions and shape on the plate's buckling behavior, including the distance between holes and the plate's thickness. The following conclusions were drawn:

Generally, the critical buckling resistance decreases as the hole size increases, regardless of whether the holes are rectangular or elliptical in shape, with varying dimensions (d_1). This applies to both cases where the load is applied parallel to the plate and cases where the load is perpendicular to the plate.

The load-bearing capacity of plates with free holes is higher than that of plates with hot buckling, whether the holes are elliptical with a major axis orientation or elliptical with a minor axis orientation. This difference is particularly noticeable when the hole size is 20 mm or smaller. Additionally, the load-bearing capacity of plates with elliptical holes with a major axis orientation is higher than that of plates with a minor axis orientation, provided that the hole size is greater than 20 mm.

Plates with elliptical holes oriented parallel to the major axis exhibit a higher load-bearing capacity than other types of holes, regardless of the hole size

Avoid using elliptical holes with a major axis orientation when subjecting the plate to compressive loads, due to the sharp change in the hole's edge, resulting in an increase in stress concentration

References:

- [1]. Jain, P., Kumar, A., "Post buckling response of square laminates with a central circular/elliptical cutout", *Composite Structures*, Vol. 65, Issue 2, 2004, India, pp. 179- 185.
- [2]. Ghannadpour, S.A.M., Najafi, A., Mohammadi, B., "On the buckling behavior of crossly laminated composite plates due to circular/elliptical cutouts", *Composite Structures*, Vol. 75, 2006, Iran, pp. 3-6.
- [3]. Varughese, B., Kishore, A., Radhakrishna, K., Rao, M.S., "Buckling and Post buckling Studies on Stiffened Composite Panels with Circular Cutouts", *National Aerospace Laboratories, Bangalore*, pp. 369-379.
- [4]. Nemeth, M.P., "Buckling and Post buckling Behavior of Compression-Loaded Isotropic with Cutouts", *NASA Technical Paper 3024*, 1990, Virginia, pp. 1-20. U.S. A
- [5]. Komur, M.A., Sen, F., Atas, A., Arslan, N., "Buckling analysis of Laminated composite plates with an elliptical/circular cutout using

- FEM", advances in Engineering software, Vol. 41, Issue 2, 2010, Turkey, pp. 161-164.
- [6]. Ganesan, C., Dash, P.K., "Elasto Buckling Behavior Of Gfrp Laminated Plate With Central Holes", *International Journal of Mechanical and Industrial Engineering*, Vol. 1, Issue 1, 2011, India, pp. 73-76.
- [7]. . Kumar, D., Singh, S.B., "Effects of boundary conditions on buckling and post buckling responses of composite laminate with various shaped cutouts", *Composite Structures*, Vol. 92, Issue 3, 2010, India, pp. 769-779.
- [8]. Kumar, A., "Buckling Analysis of Woven Glass epoxy Laminated Composite Plate", M.Sc., *Technology in Civil Engineering*, National Institute of Technology Rourkela, Rourkela-769008, Orissa, India, pp. 1-63, 2009.
- [9]. William, L.Ko., "Anomalous Buckling Characteristics of Laminated Metal-Matrix Composite Plates with Central Square Holes", *NASA Technical Paper 206559*, 1998, California/ U.S.A., pp. 1-22.