

## Speed Control of Induction Motor by Using Intelligence Techniques

S. Riaz Ahamed\*, J. N. Chandra Sekhar\*\*, Dinakara Prasad Reddy P\*\*\*

Department of EEE, Sri Venkateswara University College of Engineering, Tirupati.

### ABSTRACT

This paper gives the comparative study among various techniques used to control the speed of three phase induction motor. In this paper, indirect vector method is used to control the speed of Induction motor. Firstly Simulink Model is developed by using MATLAB/ Simulink software. PI controller, Fuzzy PI Hybrid controller, Genetic Algorithm (GA) are the techniques involved in control Induction motor and the results are compared. By converting three phase supply currents coming from stator to Flux and Torque components of current the speed responses such as rise time, overshoot, settling time and speed regulation at load have been observed and compared among the techniques. The PI controller parameters defined by an objective function are calculated by using Genetic Algorithms presented good performance compared to Fuzzy PI Hybrid controller which has parameters chosen by the human operator.

**Keywords**—Induction Motor, PI Controller, Fuzzy PI Hybrid Controller, Indirect Vector control, Genetic Algorithm

### I. Introduction

Now a day's Induction motors are the work horses of many industries which also replaced DC machines with their various advantages like lack of commutator, lower cost, reduced maintenance cost, robust, less weight and rugged structure. Because of their complex characteristics, it is not easier to control the speed of Induction motor like DC motor, so the vector control is used. It is introduced by Blaschke and Hasse has resulted in remarkable change in the field of electrical drives. Indirect vector control is used in this paper which is one of the types of vector control. It is very popular form of control of Induction motor because this control strategy can provide the same performance as achieved from a separately excited DC Motor.

The simple structure and its good performance has made the PI controller the best controller in the industry. Its functions depends on two parameters namely proportional gain Kp and Integral gain Ki. Several methods can be used to tune PI controller. The Fuzzy set theory, introduced by L.Zadeh is the mathematical tool for Fuzzy Logic Controller (FLC). It can be used in control of Induction Motor because of its advantages such as it does not need a mathematical model for the system, it is just based on linguistic rules with IF-THEN general structure which is based on human logic.

Methods such as Pole assignment method and Ziegler-Nichols method have major inconvenience as it is necessary to have prior knowledge of various parameters of the Induction motor. An optimization procedure can be developed to design the good controller. Genetic Algorithm has been employed

successfully to solve the complex optimization problems. The parameters of different controllers can be determined by using Genetic Algorithm due to their reasonable accuracy and fast convergence.

The PI controller parameters are determined by minimizing Objective Function. The goal of this work is to show that Optimization can be achieved by optimization of PI Controller parameters. This can be observed by comparing the results of Genetic Algorithm based PI controller with PI, Fuzzy PI Hybrid Controller.

### II. Dynamics Of Induction Motor

The Squirrel cage Induction Motor using the Direct axis and Quadrature axis (d-q) theory in the stationary reference frame [1-2] shown in the figures below needs less variables and analysis becomes easy.

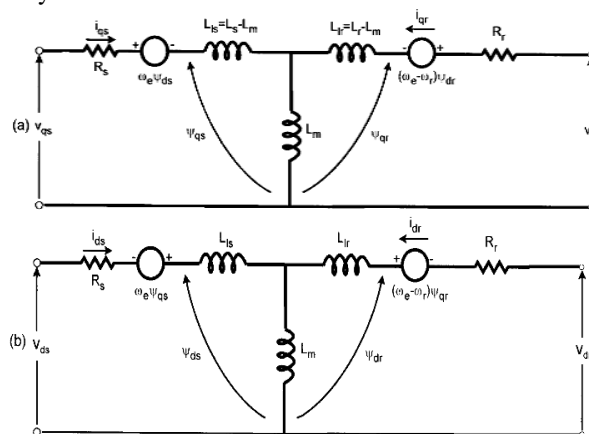

Fig. 1. Stator and rotor axis in two axis reference frame (a)q-axis and (b)d-axis

**A. Electrical system of Induction Motor**

$$\begin{bmatrix} V_{ds} \\ V_{qs} \\ 0 \\ 0 \end{bmatrix} = \begin{bmatrix} R_s + SL_s & -\omega L_s & SL_m & -\omega L_m \\ \omega L_s & R_s + SL_s & \omega L_m & SL_m \\ SL_m & -(\omega - \omega_r)L_m & R_r + SL_r & -(\omega - \omega_r)L_r \\ (\omega - \omega_r)L_m & L_m \partial & (\omega - \omega_r)L_r & R_r + SL_r \end{bmatrix} \begin{bmatrix} i_{ds} \\ i_{qs} \\ i_{dr} \\ i_{qr} \end{bmatrix}$$

$$\phi_{qs} = L_s i_{qs} + L_m i_{qr} \quad \phi_{ds}$$

$$= L_s i_{ds} + L_m i_{dr}$$

$$\phi_{qr} = L_r i_{qr} + L_m i_{qs} \quad \phi_{dr}$$

$$= L_r i_{dr} + L_m i_{ds}$$

$$L_s = L_{ls} + L_m \quad L_r = L_{lr} + L_m$$

$$T_e = \left(\frac{3}{2}\right) \left(\frac{P}{2}\right) (\phi_{ds} i_{qs} - \phi_{qs} i_{ds})$$

**A. Mechanical system of Induction Motor**

$$\frac{d}{dt} \omega_m = \frac{1}{2H} (T_e - F\omega_m - T_m)$$

$$\frac{d}{dt} \theta_m = \omega_m$$

Where,

$R_s, L_{ls}$  : Resistance and leakage inductance of stator

$R_r, L_{lr}$  : Resistance and leakage inductance of rotor

$L_m$  : The magnetizing Inductance

$L_s, L_r$  : Stator and rotor inductances

$V_{qs}, i_{qs}$  : q axis component of stator voltage and current

$V_{qr}, i_{qr}$  : q axis component of rotor voltage and current

$V_{ds}, i_{ds}$  : d axis component of stator voltage and current

$V_{dr}, i_{dr}$  : d axis component of rotor voltage and current

$\phi_{qs}, \phi_{ds}$  : q and d axis components of stator flux

$\phi_{qr}, \phi_{dr}$  : q and d axis components of rotor flux

$\omega_m$  : Angular velocity of rotor

$\theta_m$  : Angular position of rotor

P : Number of poles

p: Pairs of Poles ( $\frac{P}{2}$ )

$\omega_r$ : Electrical angular velocity ( $\omega_r \cdot p$ )

$\theta_r$ : Electrical rotor angular position ( $\theta_m \cdot p$ )

$T_e$ : Electromagnetic Torque

$T_m$ : Mechanical Torque on Shaft

J: Load Inertia Constant

F: Friction Coefficient

**III. Indirect Vector Control**

The block diagram shown below is the Indirect Vector Control Technique. Two control loops will

control induction motor drive namely Internal Pulse Width Modulation current control loop and External Speed control loop [3].

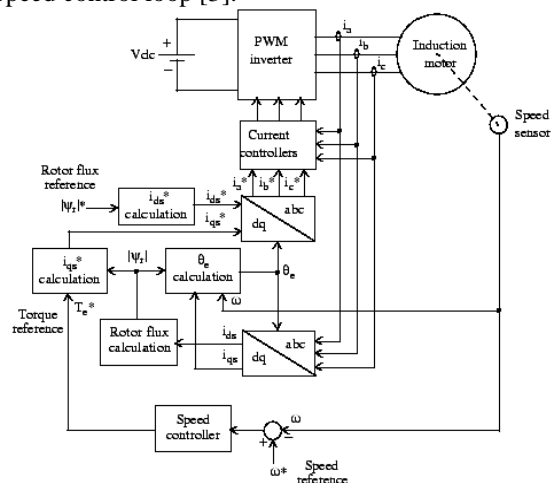

Fig. 2. Block Diagram of Indirect Vector Control Technique.

The indirect vector control method is essentially the same as direct vector control, but the unit vector signals ( $\cos\theta_e$  and  $\sin\theta_e$ ) are generated in feed forward manner using the measured rotor speed  $\omega_r$  and the slip speed  $\omega_{sl}$ . Indirect vector control is widely used in industrial applications. Current-Controlled PWM Inverter acts as three phase sinusoidal current source to Induction motor. The error between reference speed  $\omega^*$  and speed  $\omega$  is given to speed controller which outputs the command Torque  $T_e^*$ .

As shown in the Block diagram above, Torque and Rotor Flux can be independently controlled by q-axis stator current  $i_{qs}$  and d-axis stator current  $i_{ds}$  respectively.

The q-axis Stator Current Reference  $i_{qs}^*$  is calculated from Command Torque Signal  $T_e^*$  as shown in below equation.

$$i_{qs}^* = \frac{2}{3} \frac{L_r}{P L_m} \frac{T_e}{|\psi_r|_{est}}$$

$|\psi_r|_{est}$  is the Estimated Rotor Flux Linkage. It can be calculated by equation shown below.

$$|\psi_r|_{est} = \frac{L_m i_{ds}}{1 + \tau_r s}$$

Where  $\tau_r = \frac{L_r}{R_r}$  is Time Constant of Rotor.

The d-axis stator current reference  $i_{ds}^*$  is calculated from Rotor flux reference input  $|\psi_r|_{est}^*$ .

$$i_{ds}^* = \frac{|\psi_r|_{est}^*}{L_m}$$

The rotor flux position  $\theta_e$  which is required for coordinate transformation is calculated from slip frequency  $\omega_{sl}$  and rotor speed  $\omega$  as shown in equation below.

$$\theta_e = \int (\omega_{sl} + \omega) dt$$

The slip frequency  $\omega_{sl}$  is calculated from stator reference current  $i_{qs}^*$  and motor parameters.

$$\omega_{sl} = \frac{L_m R_r}{|\Psi_r|_{est} L_r} i_{qs}^*$$

The current references  $i_{qs}^*$  and  $i_{ds}^*$  are converted into three phase currents  $i_a^*, i_b^*, i_c^*$  by using Park's Transformation for the current regulators. The current regulators will use the reference currents and the measured currents to form the inverter gating signals.

To provide a good dynamic response during transient conditions, the speed controller should maintain the motor speed equal to reference speed input.

#### IV. Speed Controllers

As already mentioned, the input to the speed controller is the speed error signal, which is difference between the reference speed and actual speed. In this paper, three types of controllers are used. They are PI controller, PI-Fuzzy Hybrid Controller, Genetic Algorithm based PI controller.

##### 4.1 PI Controller

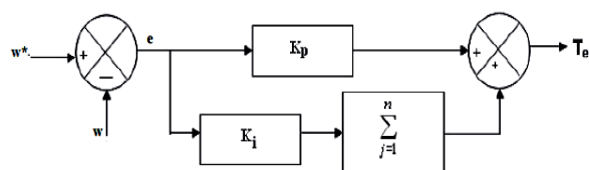

Fig. 3. Block Diagram of PI Controller

Command Torque is the output signal of controller where  $K_p$  is the proportional gain and  $K_i$  is the integral gain.

$$T_{e(n)} = T_{e(n-1)} + K_p \Delta e(n) + K_i e(n)$$

If the gains of the controller exceed a certain value, the variations in the command torque become too high and will decrease stability of the system. To overcome this problem, a limiter ahead of the PI controller is used.

$$T_{e(n+1)} = \begin{cases} T_{emax} & \rightarrow T_{e(n+1)} \geq T_{emax} \\ -T_{emax} & \rightarrow T_{e(n+1)} \leq -T_{emax} \end{cases}$$

##### 4.2 Fuzzy Logic Controller

Good Dynamic stability of induction motor is achieved when it has a good performance under transient stability conditions such as Sudden Load application or sudden load removal and sudden increase or decrease in speed. In PI controller, the tuning parameters depend on the ratings of the motor but Fuzzy logic Controller does not require any model of the motor and can handle complex nonlinearities.

The Fuzzy logic controller shown in the figure has three functional blocks

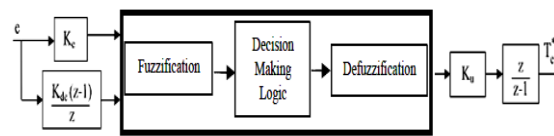

Fig. 4. Fuzzy Logic Controller.

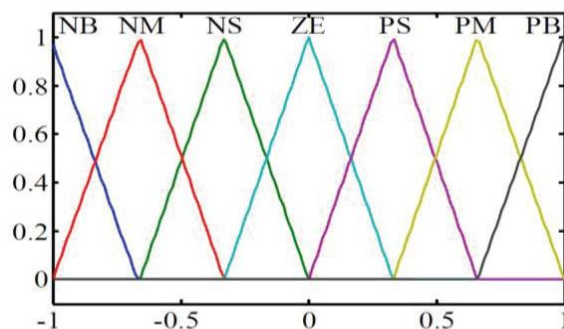

Fig.5. Input Membership Functions for error speed (e) rate of change of error speed (de)

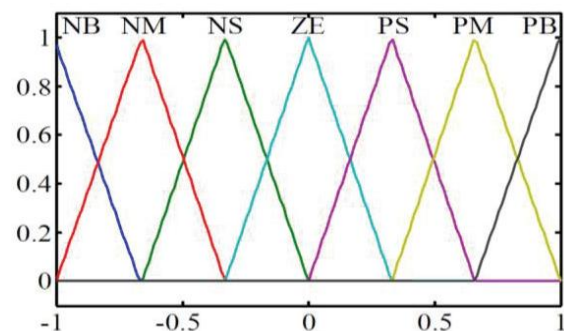

Fig.6. Output Membership Function of Fuzzy Logic Controller.

Table 1. Rule Matrix for Fuzzy Logic Controller

e \ Ce	NB	NM	NS	ZE	PS	PM	PB
NB	NM	NS	ZE	PS	PM	PB	PS
NM	NS	ZE	PS	PS	PM	PB	PM
NS	ZE	PS	PM	PB	PB	PB	ZE
ZE	NB	NM	NS	ZE	PS	PM	PB
PS	NM	NS	ZE	PS	PS	PM	PB
PM	NS	ZE	PS	PM	PM	PM	PB
PB	ZE	PS	PM	PB	PB	PB	PB

Triangular Membership functions are used to represent input and output variables such as NB – Negative Big, NM – Negative Medium, NS – Negative Small, ZE – Zero, PS – Positive Small, PM – Positive Medium, PB – Positive Big. Here, Membership functions should be normalized between -1 to +1[4].

The Fuzzy Rules are represented using IF-THEN form. MAX-MIN Inference algorithm and Center of Gravity Defuzzification Approach is used to get Crisp output from Fuzzy Logic Controller. The fuzzy

rules were designed based on the dynamic behavior of the error signal.

### 4.3 PI Fuzzy Hybrid Controller

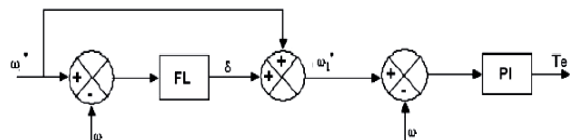

Fig. 7. Block Diagram of PI Fuzzy Hybrid Controller

This controller [3-5] has the advantages of both PI and Fuzzy Logic controller. Fuzzy logic is used for pre-compensation of reference speed, which changes reference speed given to PI controller in accordance to rotor speed as shown in figure above [3].

### 4.4 Genetic Algorithm based PI Controller

The simplified dynamic Model of Induction Motor drive [6-7] is represented by the block diagram shown below.

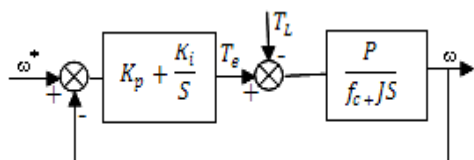

Fig. 8. Block diagram of speed system controller

If  $T_L = 0$ , then the Transfer Function is,

$$G(S) = \frac{(K_p S + K_i) \frac{P}{J}}{S^2 + \frac{f + K_p P}{L_r} S + \frac{K_i P}{J}}$$

The characteristic Equation is given as follows

$$P(S) = S^2 + \frac{f + K_p P}{J} S + \frac{K_i P}{J} = 0$$

By the imposition of two poles complex combined with real part negative,  $S_{1,2} = \rho(-1 \pm j)$ , we get the equations to find  $K_p$ ,  $K_i$  values

$$K_i = \frac{2J\rho^2}{P}$$

$$K_p = \frac{2\rho J - f}{P}$$

Where  $\rho$  is a Positive Constant.

Genetic Algorithms have been used to solve difficult problems with objective functions that do not possess “nice” properties such as continuity, differentiability, satisfaction of the Lipchitz condition etc. An objective Function is developed by above equations and minimized using Genetic Algorithm to find  $K_p$ ,  $K_i$  values.

Genetic Algorithm was first developed by John Holland and his colleagues in 1975. It is a stochastic global search method that mimics the process of Natural Evolution. The Genetic Algorithm starts with no knowledge of the correct solution and depends entirely on responses from its environment and evolution operators(i.e. Reproduction, Crossover and

Mutation) to arrive at the best solution. GA maintains and manipulates a population of solutions and implements a “Survival of the Fittest” strategy in their search for better solutions. This provides an implicit as well as explicit parallelism that allows for the exploitation of several promising areas of the solution space at the same time. By starting at several independent points and searching in parallel, the algorithm avoids local minima and convergence to sub optimal solutions. In this way, GA has been shown to be capable of locating high performance areas in complex domains without experiencing the difficulties associated with high dimensionality, as may occur with gradient descent techniques or methods that rely on derivative information.

Genetic Algorithm [8-11] mainly consists of three stages: Selection, Crossover and Mutation. New individuals were created by performing these operations which may be better than their parents. This algorithm is repeated for many generations and finally stops when reaching individuals that represent optimal solution to the problem.

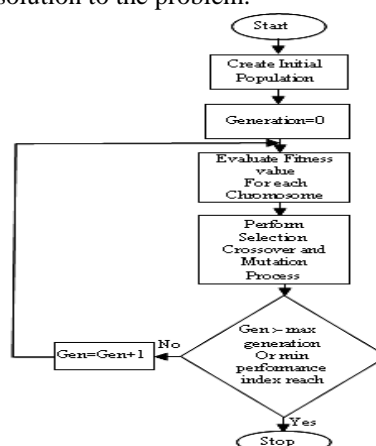

Fig. 9. Genetic Algorithm Architecture

In every generation, the genetic operators are applied to selected individuals from present population in order to create new population. Generally, the three main genetic operators of reproduction, crossover and mutation are performed. To apply these operators, different probabilities are chosen so that speed of convergence can be controlled.

Reproduction is creation of new population by simply copying the selected individuals without changing them. Also there is a probability of selection from new population by already developed solution. There are number of selection methods available based on same principle i.e. giving large probability selection for fitter chromosomes.

Once the selection process is completed, crossover operation is initiated which swaps certain parts of the two individuals in a bid to capture the good parts of old population and create better new

ones. The crossover probability indicates how often crossover is performed. Typically this operator is applied at a probability range of 0.6 to 0.8. The mutation operator plays a secondary role in the evolution .It helps to keep diversity in the population by discovering new or restoring lost genetic materials by searching the neighborhood solution space. Mutation occurs with a small probability rate of 0.1% to 10% of the entire population.

Genetic Algorithm can be used to tune the gains of PI Speed Controller as shown in figure below.

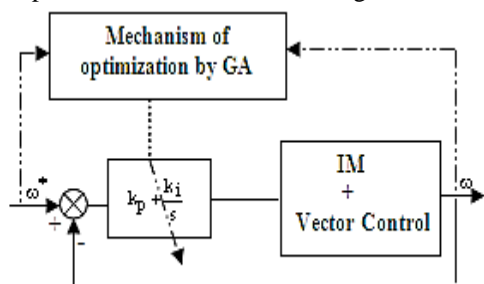

Fig.10. Structure of the technique of optimization of the PI controller by GA

The Objective Function can be written as shown below

$$\text{Fitness} = \int_0^t e^2(t)dt = \int_0^t (\omega^*(t) - \omega(t))^2 dt$$

The block of the objective function is used to estimate the performances of the PI controller by minimizing this function.

The genetic algorithm parameters chosen for the tuning purpose are shown below.

Table 2. Parameters of Genetic Algorithm

GA Property	Value
Population Size	60
Maximum no. of Generations	100
Crossover Probability	0.8
Mutation Probability	0.1
Tolerance	10 <sup>-6</sup>

After giving the above parameters to GA, the PI controller can be easily tuned and thus system performance can be improved. The parameters of the PI speed controller obtained according to the procedure of optimization by the technique of the GA are given as Kp = 11.3006, Ki = 0.5609.

### V. Simulation Results

The Simulation results for Sudden Speed variation, sudden application and removal load are observed. Initially, motor is running 120rad/sec, suddenly speed is changed to 160rad/sec at 0.2sec. Here Rise time, Peak overshoot, settling time is observed for all controllers. The Load Torque of

10N-m is applied suddenly to motor at 2sec and removed at 2.5sec. Here speed regulation at load is calculated for all controllers.

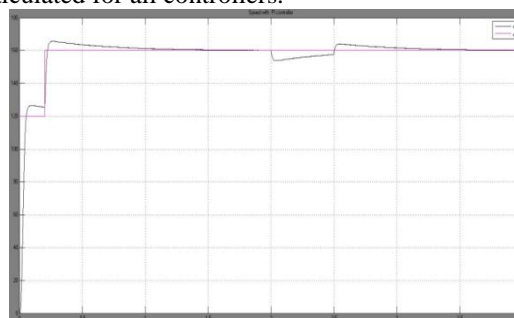

Fig.11. Speed Response with PI controller

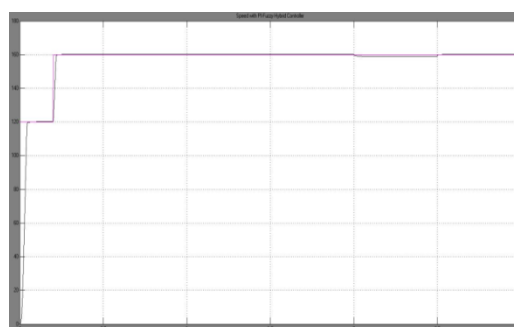

Fig. 12. Speed Response with PI-Fuzzy Hybrid Controller

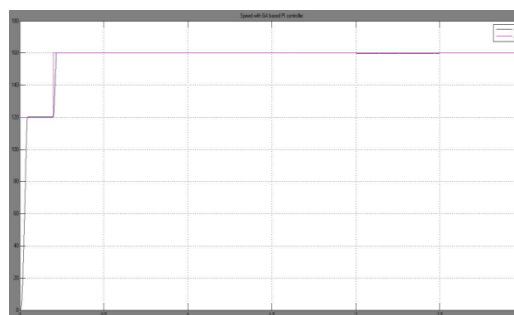

Fig.13. Speed Response with GA based PI Controller.

From the simulation results of speed responses, the rise time, peak overshoot, settling time and speed regulation are better with GA based PI controller compared to PI and PI-Fuzzy Hybrid Controller.

Table.3. Parameters using different Controllers.

Controllers Parameters	PI	PI- Fuzzy Hybrid	GA based PI
Rise Time(sec)	0.231	0.225	0.219
Peak Overshoot(rad/sec)	165	160.2	160.05
Settling Time(sec)	1.5	0.225	0.222
Speed Regulation (%)	4.36	0.75	0.31

## VI. Conclusion

In this paper Indirect Vector Control is used to control the speed of Induction Motor. The simulation is carried out using MATLAB/Simulink Software. The GA based PI controller showed better performance compared to PI and PI-Fuzzy Hybrid Controllers in terms of Rise time, Peak overshoot and Settling time as well as Speed Regulation.

Appendix: Induction Motor Specifications.

Rated power	1.5 kW
Voltage	220V
Frequency	50Hz
Rotor Type	Squirrel Cage
Stator resistance(Rs)	4.85Ω
Rotor resistance(Rr)	3.805Ω
Stator inductance(Ls)	0.274H
Rotor inductance(Lr)	0.274H
Mutual inductance(Lm)	0.258H
Moment of inertia(J)	0.031kg-m <sup>2</sup>
Friction Coefficient(f)	0.00114Nm/rad

## References

- [1] Bose, B. K, Power Electronics and AC Drives, Prentice-Hall, Englewood Cliffs, N.J, 1986.
- [2] Rajesh Kumar, R.A.Gupta, S.V.Bhangale, "Indirect Vector Controlled Induction Motor Drive with Fuzzy Logic Based Intelligent Controller", IETECH Journal of Electrical Analysis, Vol: 2, No: 4, 211-216, 2008.
- [3] HosseinEbadi Kalhooasthti, Dr.Mehdi Shahbazian, "Hybrid Speed Control of Induction Motor using PI and Fuzzy Controller", International Journal of Computer Applications, Vol: 30, No: 11, 2011.
- [4] SoudElabed.H, MailefAli.M, Abdulmalek Jamal.S, "Indirect Field Oriented Control of Induction motor drive using fuzzy logic controller", IEEE 8<sup>th</sup> Conference on Industrial Electronics and Applications, 2013.
- [5] MuawiaA.Magzoub,NordinB.Saad,Rosdiazli B.Ibrahim, "An Intelligent Speed control for indirect field oriented induction motor drives", IEEE conference on Clean Energy and Technology, 2013.
- [6] MhamedChebre, AbdelkaderMeroufel, Yessema Bendaha, Speed control of Induction Motor using Genetic Algorithm based PI Controller, Acta polytechnic Hungarica, Vol: 8, No: 6, 2011.
- [7] R. Anulmozhiyal and Dr. K. Baskarn, "Speed Control of Induction Motor Using Fuzzy PI and Optimized Using GA", International Journal of Recent Trends in Engineering, Vol. 2, No. 5, November 2009.
- [8] Reddy P, Dinakara Prasad. "Application of Loss sensitivity Factor and Genetic Algorithm for Capacitor placement for Minimum Loss in radial distribution system" International Journal of Engineering Sciences & Research Technology (2013): 2400-2403.
- [9] Dinakara Prasad Reddy P, C. Hari Prasad, M C V Suresh, "Capacitor Placement Using Bat Algorithm for Maximum Annual Savings in Radial Distribution systems" Vol. 4 - Issue 12 (December - 2014), International Journal of Engineering Research and Applications (IJERA) , ISSN: 2248-9622 , [www.ijera.com](http://www.ijera.com)
- [10] Sunil Kumar J, P.Dinakara Prasad Reddy, V.Leela, V.Rajanikanth."Improvement Of Voltage Profile In Power System Network With SVC And UPFC By Using Optimal Genetic Algorithm." International Journal Of Electrical, Electronics and Computer Systems (IJECS) 1.2 (2011): 61-65.
- [11] Dinakara Prasad Reddy P, Sreenivasulu A. "Optimal Capacitor Placement for Loss Reduction in Distribution Systems Using Fuzzy and Hybrid Genetic Algorithm", Vol.2 - Issue 11 (November - 2013), International Journal of Engineering Research & Technology (IJERT) , ISSN: 2278-0181 , [www.ijert.org](http://www.ijert.org)