

## An Efficient Approach to Zero Crossing Detection Based On Opto-Coupler

Ankita Gupta<sup>#</sup>, Rajeev Thakur<sup>#</sup>, Sachin Murarka<sup>#</sup>  
<sup>#</sup>NIIST, Bhopal, India

### Abstract

Zero crossing detection is the most common method for measuring the frequency or the period of a periodic signal. This paper presents a comparative study of various zero crossing detector techniques. The accuracy of measuring zero crossing for synchronizing power system control and instrumentation requires a diverse approach to minimize phase detection errors from signals corrupted with noise and extraneous signals. An approach to detect zero crossing with the use of opto coupler is detailed describe in the paper. The issues related to the previous approaches has been discussed along with their pros and cons.

**Keywords**— Zero Crossing Detector, Delay, Semiconductor, Interpolation.

### I. INTRODUCTION

Zero crossing detection is the most common method for measuring the frequency or the period of a periodic signal. When measuring the frequency of a signal, usually the number of cycles of a reference signal is measured over one or more time periods of the signal being measured. Measuring multiple periods helps to reduce errors caused by phase noise by making the perturbations in zero crossings small relative to the total period of the measurement. The net result is an accurate measurement at the expense of slow measurement rates.

Zero crossing is the point of choice for measuring phase and frequency. The reference is usually easy to establish and the signal's amplitude rate of change is maximum at signal zero. Phase synchronized triggering requires placing additional constraints on zero crossing detection.

Weidenburg et. al. reviewed several method for synchronizing for firing thyristor based power converters and proposed adaptive online waveform reconstruction. [1] Vainio et. al. describes a predictive digital filter for noise reduction. [2][3][4].

Depending upon the frequency for a particular application and the degree of signal processing, these methods can require high-speed processing components that are too expensive for low cost applications. Fairchild Semiconductor has developed special purpose integrated circuits for silicon controlled rectifier (SCR) and triac control for low power applications. Such optical-isolated devices offer an additional advantage of electrical isolation between instrumentation and gate firing circuits. [4]

However, the design has no provision for mitigating multiple zero crossing nor does it compensate for diode forward voltage drop.

A zero crossing detector literally detects the transition of a signal waveform from positive and negative, ideally providing a narrow pulse that

coincides exactly with the zero voltage condition. At first glance, this would appear to be an easy enough task, but in fact it is quite complex, especially where high frequencies are involved. In this instance, even 1kHz starts to present a real challenge if extreme accuracy is needed.

The not so humble comparator plays a vital role - without it, most precision zero crossing detectors would not work, and we'd be without digital audio, PWM and a multitude of other applications taken for granted.

A key difference is that the ZC estimator operates only on the time/phase coordinates of the real and imaginary zero crossings. An advantage of this approach is that no arctangent operations are required since the phase of the signal at zero crossings is known (modulo  $2\pi$ ). Another advantage of this approach is that the number of zero crossing is typically less than N. A sequential least squares implementation of the zero-crossing estimator is also presented in which the phase and frequency estimates are updated as each new crossing is detected. This feature provides the availability for real-time applications.

The zero-crossing technique is one of the methods enabling to evaluate the delay time of propagating waves. The main idea of this technique is that using some threshold level the half period of the signal exceeding this level is determined).

In the second step the time instance at which the signal crosses the zero level is estimated. The main advantage of such approach is that this zero-crossing instant in some ranges does not depend on the amplitude of the signal. In guided wave applications when not one, but several zero-crossing instants are determined it enables to reconstruct the segment of the phase velocity dispersion curves [5]. This is a very

important feature of the technique, because no other delay time measurement techniques enable to do this. However, in order to apply it correctly all peculiarities of the method should be investigated, possible sources of the errors analysed and the expected level of them estimated. The zero crossing technique many years was widely used even in an analog electronics for ultrasonic measurements and later was well known in the numerical implementations. However when the signal is digitized many questions arise related to different implementations.

The approach based on just selection of the closest to zero sample of the signal possesses a relatively low accuracy. The zero crossing point can be determined also using a linear interpolation between two closest to the zero points.

## II. ZERO CROSSING MEASUREMENT TECHNIQUES

Whether measuring period, frequency, or phase, the sources of errors are the same. When measuring a signal for the purposes of synchronization, fast and accurate frequency measurements are required. [6][7]. This requirement also translates into low phase distortion that can be introduced by frequency filtering and by measurement delays. The purpose of the instrumentation circuits and techniques discussed below are to reduce frequency errors due to multiple zero crossings (more than two per period) and reduce phase errors by advanced or delayed zero crossing.

Methods that require extensive processing have significant time delays from when changes of input frequency occur to when the change is reflected on the output. For this reason, methods described in this paper exclude highly computational methods including DFT and Wavelet type algorithms. The discussion methods is limited here to hardware and combined hardware and software techniques with low process delay. Although these methods can be applied to any frequency, the discussion here focuses on electric power system applications.

### A. Pre-Detection Low Pass filtering

Low pass filtering or band pass filtering helps to restrict the bandwidth to the frequencies close to the frequency of the signal being measured. This technique is well suited For signals that are expected to have small deviations about a nominal fixed frequency. It is also well suited for signals corrupted by harmonics or other periodic signals that are sufficiently distinguishable from the signal of interest.

### B. Post Processing Signal Conditioning

Multiple outputs for a single zero crossing must be expected in designs requiring accuracy and precision. Digital processing of the output signal does present significant advantages. There are two approaches: rule based and digital filtering. Rule based design eliminates events that don't meet expected

timing requirements. This approach inhibits zero crossing detection for a specified period after an earlier detection event. This approach relies on the statistical probability that the next zero crossing will be close to the next half period. The inhibit period must be constrained to allow natural variations in the input signal. Digital filtering has the ability to discriminate events based upon frequency of occurrence just as passive filtering but overcomes their disadvantages by having high accuracy and predictability.

Such a method is the software implementation of a phase locked loop(PLL) with feed-forward control described by Walland Hess.[6]

The phase locked loop does compensate for advanced or delayed zero crossing detection due to noise and even, to a degree, that which is caused by harmonic or alien signal corruption. There is a compromise between the degree of rejection and the speed of adapting to new steady state conditions. There is no phase error because of the nature of the phased locked loop. Capture and lock dynamics can be dynamically changed if the PLL is implemented in software. Implementing a feed-forward algorithm increases the filter's response to changes in input frequency.

### C. Simple Optical Isolated Semiconductor Devices.

One of the more simple approaches is to use an optical isolator with a Schmitt triggered logical output such as the TLP2200 in a circuit represented by top half of Fig. 3. [7] The data sheet for the TLP2200 specify that the LED forward voltage drop is 1.55 to 1.7vdc with a negative mv/°C temperature coefficient. This voltage drop constitutes a phase shift that is device dependent, input signal level, and temperature dependent. Let the input signal be characterized by (1). The approximate slope of the input signal at the zero crossing is described by (2). Equation (3) provides the expression that represents the first order approximation of the phase shift as a function of volts around the zero crossing. Thus, for a 12 vac input signal,  $\alpha$  equals 3.38 degrees/volt.

$$x(t) = Am \cdot \sin(\omega t) \tag{1}$$

$$s = \frac{d(x(t))}{dt} = \omega Am \cdot \cos(\omega t) \Big|_{t=0} = 0 \text{ volts / s} \tag{2}$$

$$\alpha = \frac{\omega \text{ rad / sec}}{\omega \cdot Am \text{ volts / sec}} = \frac{1}{Am} \text{ rad / volt or} \tag{3}$$

$$\alpha = \frac{180}{\pi Am} \text{ }^\circ \text{ angular per volt}$$

#### D. Zero-Crossing Detection by Interpolation

The implementation used in this design identifies two points on the sine wave: the first just before the positive going zero crossing and the second just after the same zero crossing. This implementation uses two optoisolators as shown in Fig. 3 to compensate for variations in level sensitivity and switching time delays. Optoisolators with Schmitt triggered outputs are used to provide additional hysteresis.

#### E. Comparator Circuits with Fixed Hysteresis

It is common to use a circuit similar to that shown in Fig. 5 to translate voltage levels and provide noise immunity using fixed hysteresis. Note that this circuit used a single voltage supply. Manufacturers of electronic comparator integrated circuits specify that the maximum negative voltage on either positive or negative input is 0.3 volts. [8] Schotky diodes, D1, and D2, clip the input voltage to limit the comparator input below recommended positive and negative levels.

Input signals with constant frequency render delays due to optoisolator output switching indistinguishable from delays due to, threshold, levels., The interpolation method requires, additional, processor, resources to accurately determine when two events occur. This usually requires that the processor have interrupt capability and capture and compare resources. The processor is programmed to capture the time of the times when Out+optoisolator output goes high and the Out+optoisolator output goes low. The true zero crossing is computed by linear interpolation between these two times. Fig. 4 shows that this method results in an improved degree of accuracy. The Est. Zero shown in Fig. 4 is computed from the phase-locked loop algorithm that estimates the next zero crossing time.[5]

#### E. Comparator Circuits with Fixed Hysteresis

It is common to use a circuit similar to that shown in Fig. 5 to translate voltage levels and provide noise immunity using fixed hysteresis. Note that this circuit used a single voltage supply. Manufacturers of electronic comparator integrated circuits specify that the maximum negative voltage on either positive or negative input is 0.3 volts. [8]

Schotky diodes, D1, and D2, clip the input voltage to limit the comparator input below recommended positive and negative levels. This method works well provided that the signal being measured is free of distortion from harmonics that can potentially generate multiple zero-crossings per fundamental cycle. The Schotky diodes do Not provide any appreciable noise rejection nor do they prevent multiple zero crossings per period due to distortion. Signal distortion from harmonic or other periodic signals Can be reduced using classical frequency filtering techniques as described above. Signals can be filtered before passing through the zero crossing detector provided that they meet the constraints previously described.

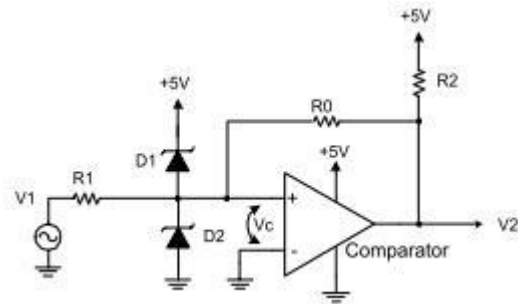

Fig 1 Comparator Circuit

#### F. Comparator Output Frequency Filtering

The comparator output is frequently connected to some other electronic device that is capable of recording high-frequency binary outputs at V2 shown in Fig. 3 and 4. Regardless of the input frequency filtering and the amount of voltage hysteresis, the probability of multiple comparator outputs for a single zero crossing remains. One is tempted to eliminate these high frequency events by using a simple passive or even active low pass filter between the comparator's output and the input to the next measuring circuit. This is not recommended because of the additional unpredictable delay from the temperature dependent low accuracy passive components. Phase locked loops are the exception to this caution as the principle is to maintain the phase relationship.

### III. Background And Literature Survey

**Milenko B. Đurić with his colleague in 2012,** present A new approach to the design of a digital algorithm for network frequency estimation is proposed. The algorithm is derived using Fourier and zero crossing technique. The Fourier method is used as digital filter and zero crossing technique is applied to the cosine and sine components of the original signal which can be corrupted by higher harmonics [9].

**B.-U. KÖHLER et.al in 2012 presents** a novel technique for the detection of QRS complexes[10] in electrocardiographic signals that is based on a feature obtained by counting the number of zero crossings per segment. It is well-known that zero crossing methods are robust against noise and are particularly useful for finite precision arithmetic. The new detection method inherits this robustness and provides a high degree of detection performance even in cases of very noisy electrocardiographic signals. Furthermore, due to the simplicity of detecting and counting zero crossings, the proposed technique provides a computationally efficient solution to the QRS detection problem. The excellent performance of

the algorithm is confirmed by a sensitivity of 99.70% (277 false negatives) and a positive predictivity of 99.57% (390 false positives) against the MIT-BIH arrhythmia database.

**Domenicantonio Grillo** gives a proposal for the estimation of the frequency of a sine signal corrupted by zero-mean additive white gaussian noise [11]. The method resorts to the histogram of the time intervals between adjacent zero-crossing samples. Validation has been carried out for various noise levels and results show that the relative error is much less than other algorithms for frequency estimation. Performances are also compared to those of numeric counters. The method can be easily implemented of low cost devices and is computationally very efficient.

**R.W. Wall et.al in 2012,** proposes a scheme for synchronizing Affects of noise, harmonics, and multi-frequency signal make frequency and period measurements difficult control events. Various methods are presented to minimize errors in period and phase measurements.

Both frequency and amplitude domain approaches are analyzed. Post detection processing allows greater accuracy. Static and dynamic hysteresis as well as interpolation methods of zero-crossing detection are investigated. The accuracy of measuring zero crossing for synchronizing power system control and instrumentation requires a diverse approach to minimize phase detection errors from signals corrupted with noise and extraneous signals. Using optical isolated gates to detect a zero crossing can result in phase distortion due to the diode's non-zero forward voltage. This phase shift can be reduced using the interpolation method [13].

Colak, I. With his colleague in 2011 proposed a novel zero crossing detector circuit, that operates as quite steady under the distorted grids due to harmonics. For this aim, a circuit has been designed using UA741, an operational amplifier, which is not affected owing to instant spikes and sags on the signals of current or voltage [14].

Methods	Mean Absolute Error	Standard Deviation
<b>PREDICTIVE FIR-BASED ZERO-CROSSING DETECTION</b>	<b>0.11909</b>	<b>1.6215</b>
<b>Simple Methods for Detecting Zero Crossing</b>	<b>0.2095</b>	<b>1.5625</b>
<b>Combined Fourier and Zero Crossing Technique</b>	<b>0.003</b>	<b>1.8624</b>
<b>Used Technique</b>	<b>0.5618</b>	<b>1.5618</b>

#### IV. CIRCUIT DIAGRAM AND IMPLEMENTATION RESULT

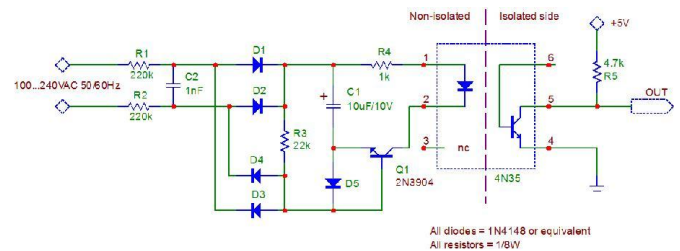

Fig 2. Circuit Diagram

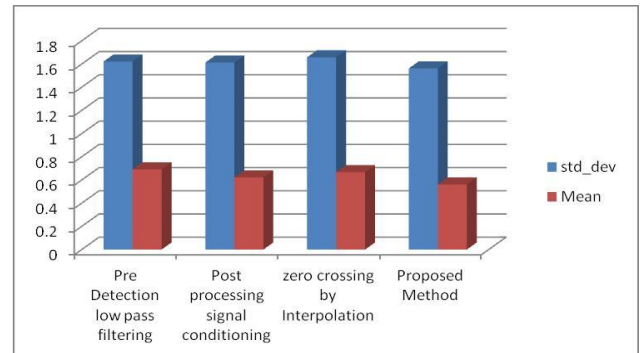

Fig 3. Bar Chart comparison between Result

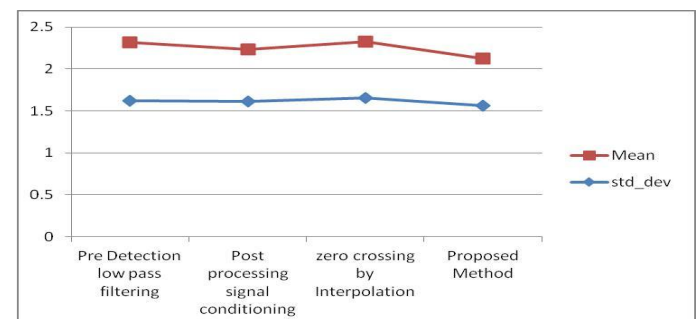

Fig 4. Line Chart comparison between Result

#### Standard Deviation Comparison

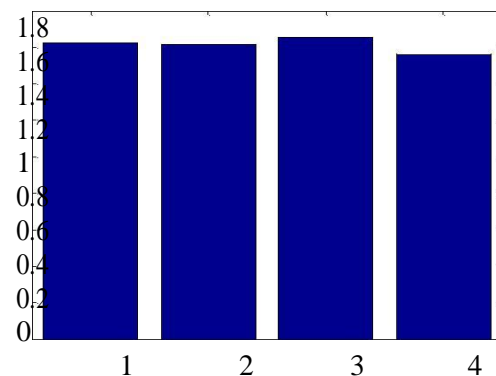

Fig 5. Standard Deviation Comparison

Mean Value Comparison

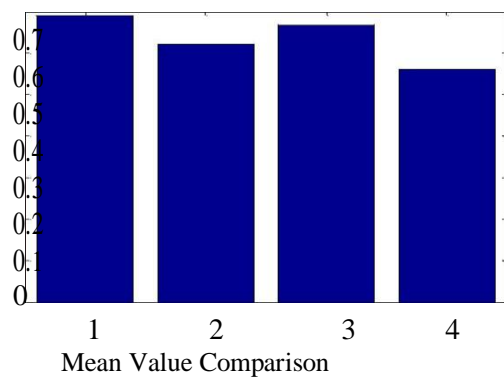

Fig 6. Mean Value Comparison

## V. CONCLUSION AND FUTURE WORK

The accuracy of measuring zero crossing for synchronizing power system control and instrumentation requires a diverse approach to minimize phase detection errors from signals corrupted with noise and extraneous signals. Using optical isolated gates to detect a zero crossing can result in phase distortion due to the diode's non-zero forward voltage. This phase shift can be reduced using the interpolation method.

The dynamic hysteresis circuit provides high signal to noise ratio without period distortion due to DC level shifts on the measured AC signal. Although proper signal conditioning can improve the reliability of period measurements, phase errors cannot be totally eliminated. Using pre-filtering and post processing can improve zero crossing detection when combined with dynamic hysteresis or the interpolation method.

## REFERENCES

- [1] Richard Weidenburg, F.P Dawson, and R Bonert, "New Synchronization Method for Thyristor Power Converters to Weak AC-Systems", *IEEE Transactions on Industrial Electronics*, VOL 40, NO 5. October, 1993, pp. 505-511.
- [2] Olli Vainio and S.J.Ovaska, "Noise Reduction in Zero Crossing Detection by Predictive Digital Filtering", *IEEE Transactions on Industrial Electronics*, VOL 42, NO 1. February, 1995, pp.58-62.
- [3] Olli Vainio and S.J. Ovaska, "Digital Filtering for Robust Zero Crossing Detectors", *IEEE Transactions on Instrumentation and Measurements*, April, 1996, pp 426-430.
- [4] Olli Vainio and S.J.Ovaska, "Adaptive Lowpass Filters for Zero-Crossing Detectors", *Proceedings of the 28 th Annual International Conference of IEEE*, Sevilla, Spain, November 5-8, 2002.
- [5] Mažeika L., Draudvilienė L., Žukauskas E. Influence of dispersion on measurement of phase and group velocities of Lamb waves. *Ultrasound*. 2009. Vol.64. No.4. P.18-21.
- [6] Wall, R.W., and H.L. Hess. "Design of Microcontroller Implementation of a Three Phase SCR Power Journal of Circuits, Systems, and Computers, Vol. 6, No. 6, March 1997, pp. 619-633.
- [7] Hess, H.L., R.W. Wall, et al. "A Microcontroller-Based Pulsed Width Modulated Voltage Source Inverter," *North American Power Symposium*, Bozeman, Montana, October 2, 1995.
- [8] LM193, LM293, LM393 Dual Differential Comparator data sheet, Texas Instruments
- [9] Milenko B. Đurić, Željko R. Đurišić, "Combined Fourier and Zero Crossing Technique for Frequency Measurement in Power Networks in the Presence of Harmonics", 2010.
- [10] B.-U. KÖHLER, C. HENNIG, R. ORGLMEISTER, "QRS Detection Using Zero Crossing Counts", *Progress in Biomedical Research*, Vol. 8, No. 3, September 2003
- [11] Domenicantonio Grillo, et.al, "An Efficient Extension of the Zero-Crossing Technique to Measure Frequency of Noisy Signals", 978-1-4577-1772-7/12/\$26.00 ©2012 IEEE.
- [13] R.W. Wall, "Simple Methods for Detecting Zero Crossing", *IEEE* 2012-10-30
- [14] Colak, I, "Design and application of a zero crossing detector circuit", *IEEE*, 2011.