

Tire Pressure Monitoring System And Fuel Leak Detection

Loya Chandreshkumar,¹ Joshi Pranav,² Chaudhari Hemraj,³ Prof. Gayatri Bokade⁴

Department of electronics & telecommunication

Nutan Maharashtra Institute of Engineering & Technology University Of Pune Pune, India

Abstract

Improper tire pressure & temperature is a safety issue that is often overlooked or ignored. A drop in tire pressure by just a few pounds per square inch (psi) can result in the reduction of fuel mileage, tire life, safety, and vehicle performance. This paper presents a kind of Tire pressure monitoring system (TPMS) with fuel leak detection, introduces the main chips and the principle of system. Key issue of system are discussed: Installation of master and slave section, Wireless signal transmission, Low power strategies. To address these problems, an automated system that will alleviate the need for actively maintaining tire pressure was designed.

Keywords—tire pressure, TPMS temperature, wireless communication,

I. INTRODUCTION

In a super highway, tire fault is very hard to prevent and a severe problem to drivers. It is one of main reasons of the sudden traffic accidents. Statistics shows that the number of the traffic accidents happened owing to tire break is about 70% of the whole. In the India, the proportion is nearly up to 37% [1].major accidents also happen due to gas leakage.

Researches indicates that the key measure of avoiding tire-break is to keep the tire pressure near to its standard value and discover tire pressure release in time. Thus, tire pressure monitoring system (TPMS) has been drawing attention of many researchers and engineers.

The majority of automobile drivers do not adequately maintain their tire pressure, even though tire loses approximately one to two pounds per square inch (PSI) of air pressure a month. Underinflated tires cause a greater contact surface area with the road, resulting in higher friction between the road and tire. This significantly decreases tire life and fuel economy. According to Doran Manufacturing, when tires are 20% underinflated, tire life and fuel economy can be reduced by 30% and 3% respectively [2]. Vehicle handling characteristics are also adversely affected due to low tire pressures. Stopping distances increase and the driver experiences a loss of steering precision and cornering stability. With all these undesirable effects, proper tire pressure should be of greater concern. The National

Highway Traffic Safety Administration (NHTSA) statistics show that 660 fatalities and 33,000 injuries occur every year as a result of low-tire pressure-related crashes [3].

II. TYPES OF TPMS

A. Direct TPMS

TPMSs are classified into two categories, namely, direct and indirect. In direct TPMSs, the pressure drop is calculated based on actual pressure measurements through sensors. In contrast, measurements such as wheel speed are used in indirect TPMSs. A direct TPMS can inform the driver about pressure deviations as low as ± 0.1 bar, that is, ± 1.45 psi. The following sections explain these types of TPMS in detail. Tire inflation is identified through pressure sensors in a direct TPMS. A low-cost, direct TPMS consists of a sensor fitted on the tire valve stem, which changes its color when the pressure drops. This sensor has low accuracy and cannot communicate data to the driver. Alternatively, a more sophisticated version of a direct TPMS consists of sensors, radio frequency transmitters and receiver, and a warning system. Each tire's pressure is measured and transmitted through its sensor and transmitter. The transmitted signals are received, decoded, and processed by the receiver to trigger the warning system through an alarm lamp, audible alarm, voice, or pressure display. The proposed system uses the direct tpms scheme for our system.

B. Indirect TPMS

An indirect TPMS predicts tire pressure drop using an observer coded in software and thus does not require tire pressure sensors. Available indirect TPMSs are based on wheel speed measurements. When the tire pressure decreases, the vehicle's weight causes the tire's diameter to decrease, which causes the tire to rotate at a different rate than when it is at full pressure. Therefore, only software is needed to implement an indirect TPMS. However, several shortcomings are associated with indirect TPMS. First, the system does not provide the actual pressure of each tire and works only when the vehicle is in motion. It warns the driver only when the pressure drop is more than 25% and, moreover, may generate false warnings when the vehicle is moving on a curved road or during tire slip on snowy roads.

III. SYSTEM ARCHITECTURE

The general scheme of TPMS and fuel leak detection is shown in figure1: Sensor, MCU, RF Transmitter, RF Receiver, Sensor, MCU, LCD. From this configuration, we can see that the general configuration can be divided into two parts first one is *Master* and second is *slave*.

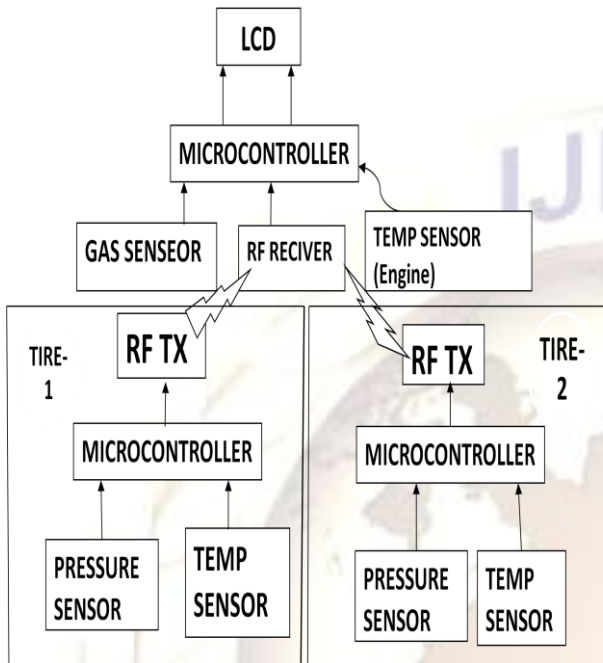

Figure 1: Block diagram of system

In master section two sensors and receiver are connected to LCD consisting of microcontroller unit. The slave section consists of two sensors and transmission module. The sensors are connected to transmission module consisting of a microcontroller unit.

A. Sensor

In the presented system we are using three types of sensor.

- 1) Pressure sensor: We choose a *MPXH6400A* provided by *FREESCALE* as a pressure sensor. It is a absolute voltage output sensor which works for pressure range 20 to 400 Kpa.
- 2) Temperature sensor: The temperature sensor of range -55° to +150°C used is *LM35* by National Instrument.
- 3) Gas sensor: The gas sensor *MQ6* is used to detect the gas leakage after 200ppm of LPG in air.

B. Radio frequency transmitter and receiver

In the system, how to effectively transmit and receive the wireless radio frequency signal is a key technique and this costs most of power. When choosing a wireless radio frequency module. We must consider power consumption, bandwidth,

speed and capability as well. So we choose *CC2500* as the radio frequency module which is provided by *TEXAS INSTRUMENTS*. It has large ranges of frequency bandwidth, operation voltage and temperature, high speed data transceive capability. The module also has many advantages such as low power consumption, high accuracy and wide range of communication up to 30 meters. It supports various modulation formats such as OOK, 2-FSK, GFSK, and MSK and has a configurable data rate from 1.2 to 500 kBauds.

C. Circuit sketch map and working principle

The sketch map of transmission circuit is shown in figure.2: in which working principle of transmission module is illustrated. In normal working state after power on both sensors sends data to MCU in analog form. The MCU's inbuilt ADC converts the analog data in digital form. Then the data is given to transmission module *CC2500* and so the data is spread out in the form of RF waves by using modulation.

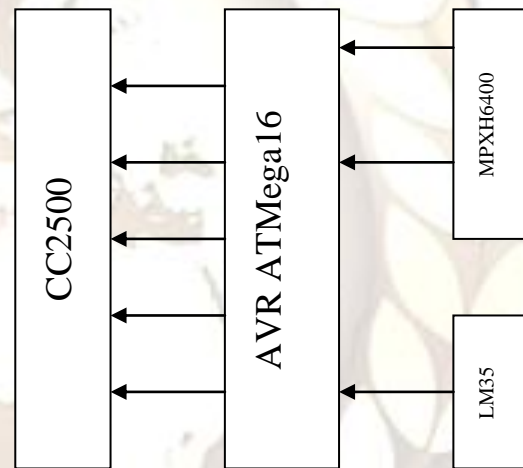

Figure 2: sketch map of transmission circuit

The sketch map of master circuit is shown in figure3. The working principle of receiving module is illustrated. After receiving the data from slave circuit and demodulating it the receiving module sends data to AVR. AVR is also accompanied with two sensors. The AVR gathers all the data and compare it with preset values.

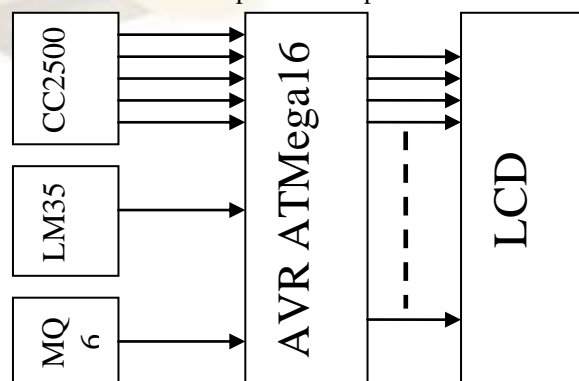

Figure 3: sketch map of master circuit

The system displays 4 pressure and temperature values on LCD circularly according to a certain interval, then judge whether temperature value or pressure value is normal so as to decide whether start warning function or not. The warning function includes pressure-too-high warning, pressure-too-low warning, tire-flat warning and temperature-too-high warning with the current values of pressure and temperature of the respective tire. When sensor detects the gas leakage, microcontroller switches the buzzer and if the gas leakage goes above a certain limit then power window will automatically opens and gas leakage warning is displayed.

IV. KEY ISSUES

A. Installation of the Master and Slave section

1) *Slave section:* Slave circuit is fitted on the ring & pressure sensor will be connected to the valve as shown in figure.4.



Figure 4: Slave section installation

There is some modification on the ring & tube is required. The tube which is required should have two valves & in ring there is only one more hole is required. In this system the breaking possibilities is very low & the tube changing will not waste the circuit. The slave circuit is water-proofed.

2) *Master section :* The master circuit is fitted nearer to the dashboard as shown in figure 5.1.

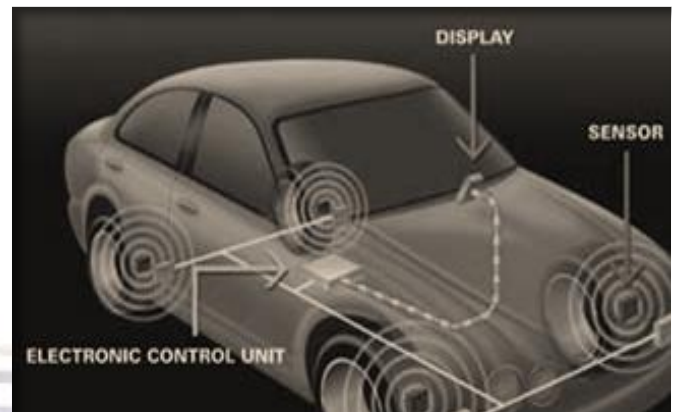

Figure 5.1: Master section installation

The display is below to the steering so it will easily draw the attention of driver as shown in figure 5.2.



Figure.5.2 LCD placement

The Gas leak detector would be nearer to gas tank so it is possible to detect faster. The engine temperature sensor should connect on the engine heat shield.

B. Wireless signal transmission

A key technique in TPMS is the stability and reliability of the wireless signal transmission, especially in super highway. Many factors, such as disadvantageous working environment in high speed and signal-shielding, may produce disturbances to signals. Besides, when we use handset and electronic devices in the car, signals will interfere with each other, and the stability of the signal transmission will also be affected. Thus, when choosing wireless signal transmission module, we choose the chips CC2500. In the meantime, in order to improve the disturbance-rejecting capability, we choose the Manchester coding, the FSK (frequency-shift keying) mode. Further it has high sensitivity (type -104dBm) & also programmable output power -20dBm~1dBm. These measures can ensure the stability and reliability of the wireless signal transmission.

C. Low power strategies

Since the battery on the transmission module should work for 10 to 12 months, decreasing power consumption is a very important task for the system. Thus, only if we make the

system sleep most of the time, it can save energy and extend the life time of the battery. In our scheme, we choose sensor *MPXH6400* which is produced by *FREESCALE & LM35* by *NATIONAL INSTRUMENTS* which are very less power consuming sensor. The most of the power is used by transmission module so concentrating on the transmission module power is very important. So we chosen RF module *CC2500* from *CHIPCON* products from *TEXAS INSTRUMENTS* which having variable programmable output power - 20dBm~1dBm. Further, when the car is driven, we can set the different intervals of the data transmission and the different intervals of testing pressure and temperature. The slave circuit can be set to power down mode when master is off or in power down mode thus, power consumption of the system is largely reduced.

V. RESULTS

The system is tested for all the functions of the developed TPMS with fuel leak detection for high-pressure, low-pressure, high-temperature, low-temperature, Fuel leak detection and high temperature of engine in artificial simulation conditions. Firstly, the measurement accuracy is achieved the corresponding standards. Secondly, it is warning abnormal states in time and rightly.

In communication, the distance of the communication should 10-12 meter. Further, when set the TPMS system in the car to test, the RF overcome large disturbances and communication also meet the practical requests; secondly, it display the pressure and temperature of the tire on LCD in time and also warning on LCD. The windows automatically open when fuel leak crosses the limit (700 ppm).

VI. CONCLUSION

The article presents a kind of scheme of direct TPMS, introduces the principle of the system. The communication can greatly improved through carefully choosing the RF module. The transmission module has the low power property. The wireless signal transmission is solved by adopting FSK, Manchester coding and CRC

checkout. The testing results indicate that the system meets the needs of the real application well. Researches show TPMS has a bright prospect.

REFERENCES

- [1] "Wireless Communication based Tire pressure monitoring system" YU Shiming, TANG Jianbin, QIU Hong, CAO Chengrong. IEEE Xplore 1-4244-1312-5/07/\$25.00©2007 IEEE.
- [2] "Keep Your Tires at Proper Inflation." Doran Manufacturing LLC. [Online]. Available at http://www.doranmfg.com/industry_studies.htm
- [3] "Vehicle Safety Research." National Highway Traffic Safety Administration. [Online]. Available at <http://www.nhtsa.dot.gov/>.
- [4] "Tire Maintenance and Safety." The Rubber Manufacturers Association. [Online]. Available at <http://www.rma.org/>.
- [5] "Federal Motor Vehicle Safety Standards; Tire Pressure Monitoring Systems; Controls and Displays," Department of Transportation and National Highway Traffic Safety Administration, full document available at www.nhtsa.dot.gov/cars/rules/rulings/TirePresFinal/
- [6] Lee Ann Obringer. "How Self-inflating Tires Work". December 10, 2004.[Online]. Available at <http://auto.howstuffworks.com/self-inflating-tire.htm>
- [7] "Awareness of mobile equipment". [Online]. Available at www.mobileawareness.com
- [8] "Tire Safety: Benefits Of Temp. & Pressure Monitoring" By: Gary Rothstein.
- [9] Federal motor carrier safety administration [Online]. Available at www.fmcsa.dot.gov
- [10] Commercial Motor Vehicle Safety and Security System Technology.