

# Enhancement of Power System Performance using FACTS Devices

Mr.C.S.Hiwarkar\*, Dr.P.G.Burade\*\*

\*( Research Scholar, Department of Electrical Engg., K.D.K.College of Engg., Nagpur University, Nagpur)  
Email: cshiwarkar@rediffmail.com )

\* (Head, Department of Electrical & Electronics Engg., ITM College of Engg., Nagpur University, Nagpur)  
Email: prakash.burade@gmail.com)

## ABSTRACT

In the last two decades, power demand has increased substantially while the expansion of power generation and transmission has been severely limited due to limited resources and environmental restrictions. As a consequence, some transmission lines are heavily loaded and the system stability becomes a power transfer-limiting factor. Flexible AC transmission systems (FACTS) controllers have been mainly used for solving various power system steady state control problems. Flexible AC transmission systems or FACTS are devices which allow the flexible and dynamic control of power systems. Enhancement of system stability using FACTS controllers has been investigated. This paper is aimed towards the benefits of utilizing FACTS devices with the purpose of improving the operation of an electrical power system. Performance comparison of different FACTS controllers has been discussed. In addition, some of the utility experience and semiconductor technology development have been reviewed and summarized. Applications of FACTS to power system studies have also been discussed.

**Keywords** - FACTS, SVC, STATCOM, SSSC, TCSC, UPFC.

## I. INTRODUCTION

The FACTS controllers offer a great opportunity to regulate the transmission of alternating current (AC), increasing or diminishing the power flow in specific lines and responding almost instantaneously to the stability problems. The potential of this technology is based on the possibility of controlling the route of the power flow and the ability of connecting networks that are not adequately interconnected, giving the possibility of trading energy between distant agents.

Flexible Alternating Current Transmission System (FACTS) is a static equipment used for the AC transmission of electrical energy. It is meant to enhance controllability and increase power transfer capability[4]. It is generally a power electronics based device. The FACTS devices can be divided in three groups, dependent on their switching technology: mechanically switched (such as phase shifting transformers), thyristor switched or fast switched, using IGBTs. While some types of FACTS, such as the phase shifting transformer (PST) and the static VAR compensator (SVC) are already well known and used in power systems, new developments in power electronics and control have extended the application range of FACTS. Furthermore, intermittent renewable energy sources

and increasing international power flows provide new applications for FACTS. The additional flexibility and controllability of FACTS allow to mitigate the problems associated with the unreliable of supply issues of renewable. SVCs and STATCOM devices are well suited to provide ancillary services (such as voltage control) to the grid and fault ride through capabilities which standard wind farms cannot provide. Furthermore, FACTS reduce oscillations in the grid, which is especially interesting when dealing with the stochastic behavior of renewable [3,6].

## II. CONTROL OF POWER SYSTEMS

### 2.1. Generation, Transmission, Distribution:

In any power system, the creation, transmission, and utilization of electrical power can be separated into three areas, which traditionally determined the way in which electric utility companies had been organized. These are illustrated in Figure 1 and are:

- Generation
- Transmission
- Distribution

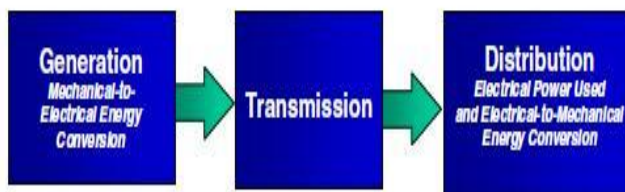

Fig-1. Block diagram of generation, transmission & distribution.

Although power electronic based equipment is prevalent in each of these three areas, such as with static excitation systems for generators and Custom Power equipment in distribution systems [8,12], the focus of this paper and accompanying presentation is on transmission, i.e, moving the power from where it is generated to where it is utilized.

### 2.2. Power System Constraints:

As noted in the introduction, transmission systems are being pushed closer to their stability and thermal limits while the focus on the quality of power delivered is greater than ever. The limitations of the transmission system can take many forms and may involve power transfer between areas or within a single area or region and may include one or more of the following characteristics:

- Steady-State Power Transfer Limit
- Voltage Stability Limit
- Dynamic Voltage Limit
- Transient Stability Limit
- Power System Oscillation Damping Limit
- Inadvertent Loop Flow Limit
- Thermal Limit
- Short-Circuit Current Limit
- Others

Each transmission bottleneck or regional constraint may have one or more of these system-level problems. The key to solving these problems in the most cost-effective and coordinated manner is by thorough systems engineering analysis[2,5].

### 2.3. Controllability of Power Systems:

To illustrate that the power system only has certain variables that can be impacted by control, we have considered here the power-angle curve, shown in Figure 2. Although this is a steady-state curve and the implementation of FACTS is primarily for dynamic issues, this illustration demonstrates the point that there are primarily three main variables that can be directly controlled in the power system to impact its performance. These are:

- Voltage
- Angle
- Impedance

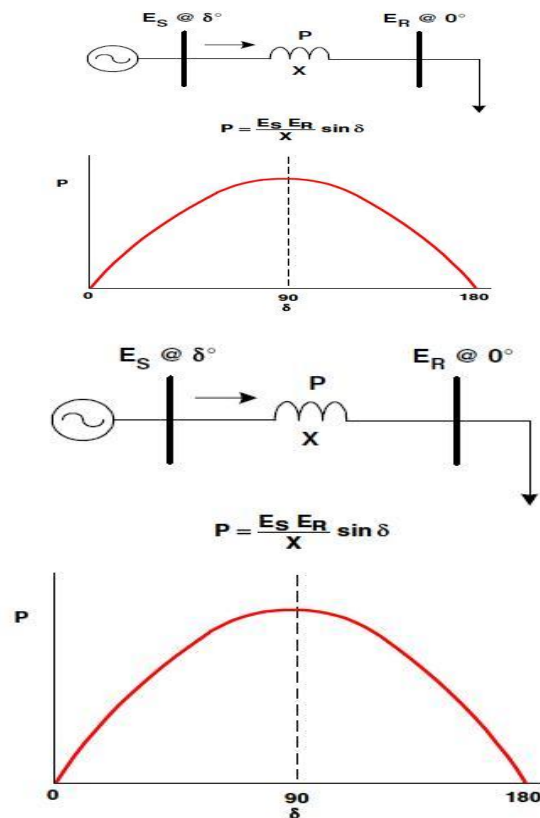

Fig – 2. Illustration of controllability of power system.

We can also infer the point that direct control of power is a fourth variable of controllability in power systems. With the establishment of “what” variables can be controlled in a power system, the next question is “how” these variables can be controlled. The answer is presented in two parts: namely conventional equipment and FACTS controllers[11].

### Examples of Conventional Equipment For Enhancing Power System Control

- Series Capacitor -Controls impedance
- Switched Shunt-Capacitor and Reactor - Controls voltage
- Transformer LTC -Controls voltage
- Phase Shifting Transformer -Controls angle
- Synchronous Condenser -Controls voltage
- Special Stability Controls-Focuses on voltage control  
but often include direct control of power
- Others (When Thermal Limits are Involved) - Can included reconductoring, raising conductors, dynamic line monitoring, adding new lines, etc.

### Example of FACTS Controllers for Enhancing Power System Control

- Static Synchronous Compensator (STATCOM)  
-Controls voltage

- Static VAR Compensator (SVC) -Controls voltage
- Unified Power Flow Controller (UPFC)
- Convertible Series Compensator (CSC)
- Inter-phase Power Flow Controller (IPFC)
- Static Synchronous Series Controller (SSSC) Each of the above mentioned controllers have impact on voltage, impedance, and/or angle (and power)
- Thyristor Controlled Series Compensator (TCSC)- Controls impedance.
- Thyristor Controlled Phase Shifting Transformer (TCPST)-Controls angle.
- Super Conducting Magnetic Energy Storage (SMES)-Controls voltage and power.

#### **2.4. Benefits of Control of Power Systems:**

Once power system constraints are identified and through system studies viable solutions options are identified, the benefits of the added power system control must be determined. The following offers a list of such benefits:

- Increased Loading and More Effective Use of Transmission Corridors.
- Added Power Flow Control.
- Improved Power System Stability.
- Increased System Security.
- Increased System Reliability.
- Added Flexibility in Starting New Generation
- Elimination or Deferral of the Need for New Transmission Lines[2].

#### **2.5. Benefits of utilizing FACTS devices:**

The benefits of utilizing FACTS devices in electrical transmission systems can be summarized as follows [1]:

- Better utilization of existing transmission system assets.
- Increased transmission system reliability and availability.
- Increased dynamic and transient grid stability and reduction of loop flows.
- Increased quality of supply for sensitive industries
- Environmental benefits Better utilization of existing transmission system assets.

### **III. Main FACTS Controllers**

#### **3.1. Static VAR Compensator (SVC)**

A static VAR compensator (or SVC) is an electrical device for providing fast-acting reactive power on high-voltage electricity transmission networks. SVCs are part of the Flexible AC transmission system device family, regulating voltage and stabilising the system. Prior to the invention of the SVC, power factor compensation was the preserve of large rotating machines such as synchronous condensers. The SVC is an automated impedance matching device, designed to bring the system closer to unity power factor. If the power system's reactive load is

capacitive (leading), the SVC will use reactors (usually in the form of Thyristor-Controlled Reactors) to consume VARs from the system, lowering the system voltage. Under inductive (lagging) conditions, the capacitor banks are automatically switched in, thus providing a higher system voltage. They also may be placed near high and rapidly varying loads, such as arc furnaces, where they can smooth flicker voltage[6].

In its simple form, SVC is connected as Fixed Capacitor-Thyristor Controlled Reactor (FC-TCR) configuration as shown in Fig. 3. The SVC is connected to a coupling transformer that is connected directly to the ac bus whose voltage is to be regulated. The effective reactance of the FC-TCR is varied by firing angle control of the antiparallel thyristors. The firing angle can be controlled through a PI (Proportional + Integral) controller in such a way that the voltage of the bus, where the SVC is connected, is maintained at the reference value[15].

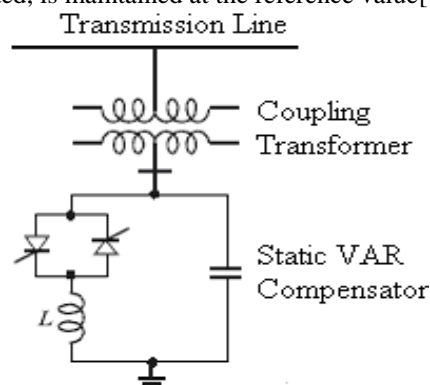

Fig.3. Configuration of SVC

#### **3.2. Thyristor-Controlled Series Capacitor (TCSC):**

TCSC controllers use thyristor-controlled reactor (TCR) in parallel with capacitor segments of series capacitor bank. The combination of TCR and capacitor allow the capacitive reactance to be smoothly controlled over a wide range and switched upon command to a condition where the bi-directional thyristor pairs conduct continuously and insert an inductive reactance into the line. TCSC is an effective and economical means of solving problems of transient stability, dynamic stability, steady state stability and voltage stability in long transmission lines. A TCSC is a series controlled capacitive reactance that can provide continuous control of power on the ac line over a wide range[8].

TCSC is one of the most important and best known FACTS devices, which has been in use for many years to increase the power transfer as well as to enhance system stability. The maincircuit of a TCSC is shown in Fig. 4.

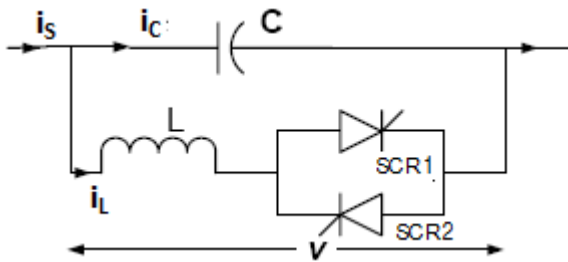

Fig.4. Configuration of TCSC

### 3.3 Static Compensator (STATCOM)

The emergence of FACTS devices and in particular GTO thyristor-based STATCOM has enabled such technology to be proposed as serious competitive alternatives to conventional SVC [21]. A static synchronous compensator (STATCOM) is a regulating device used on alternating current electricity transmission networks. It is based on a power electronics voltage-source converter and can act as either a source or sink of reactive AC power to an electricity network. If connected to a source of power it can also provide active AC power. It is a member of the FACTS family of devices. Usually a STATCOM is installed to support electricity networks that have a poor power factor and often poor voltage regulation. There are however, other uses, the most common use is for voltage stability. From the power system dynamic stability viewpoint, the STATCOM provides better damping characteristics than the SVC as it is able to transiently exchange active power with the system[9].

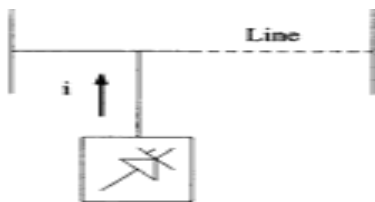

Fig.5. Symbolical diagram of STATCOM

### 3.4. Static Synchronous Series Compensator (SSSC):

The SSSC is one of the most recent FACTS devices for power transmission series compensation. It can be considered as a synchronous voltage source as it can inject an almost sinusoidal voltage of variable and controllable amplitude and phase angle, in series with a transmission line. The injected voltage is almost in quadrature with the line current. A small part of the injected voltage that is in phase with the line current provides the losses in the inverter. Most of the injected voltage, which is in quadrature with the line current, provides the effect of inserting an inductive or capacitive reactance in series with the transmission line. The variable reactance influences the electric

power flow in the transmission line. The basic configuration of a SSSC is shown in Fig.5.

A SSSC is able to exchange active and reactive power with the transmission system. But if our only aim is to balance the reactive power, the energy source could be quite small. The injected voltage can be controlled in phase and magnitude if we have an energy source that is big enough for the purpose.

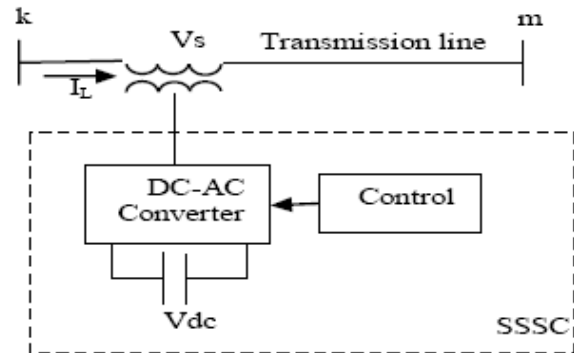

Fig.6. Simplified diagram of SSSC

### 3.5. Unified Power Flow Controller (UPFC):

A unified power flow controller (UPFC) is the most promising device in the FACTS concept. It has the ability to adjust the three control parameters, *i.e.* the bus voltage, transmission line reactance, and phase angle between two buses, either simultaneously or independently. A UPFC performs this through the control of the in-phase voltage, quadrature voltage, and shunt compensation. The UPFC is the most versatile and complex power electronic equipment that has emerged for the control and optimization of power flow in electrical power transmission systems. It offers major potential advantages for the static and dynamic operation of transmission lines. The UPFC was devised for the real-time control and dynamic compensation of ac transmission systems, providing multifunctional flexibility required to solve many of the problems facing the power industry. Within the framework of traditional power transmission concepts, the UPFC is able to control, simultaneously or selectively, all the parameters affecting power flow in the transmission line. Alternatively, it can independently control both the real and reactive power flow in the line unlike all other controllers[6;17].



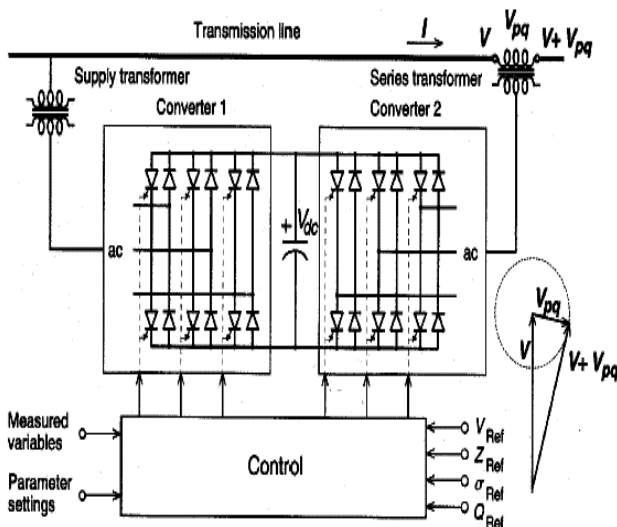

Fig – 7. Unified Power Flow Controller

#### IV. FACTS applications to steady state Power.

##### System problems:

For the sake of completeness of this review, a brief overview of the FACTS devices applications to different steady state power system problems is presented in this section. Specifically, applications of FACTS in optimal power flow and deregulated electricity market will be reviewed.

##### 4.1. FACTS Applications to Optimal Power Flow:

In the last two decades, researchers developed new algorithms for solving the optimal power flow problem incorporating various FACTS devices [11]. Generally in power flow studies, the thyristor controlled FACTS devices, such as SVC and TCSC, are usually modeled as controllable impedance [4, 9]. However, VSC-based FACTS devices, including IPFC and SSSC, shunt devices like STATCOM, and combined devices like UPFC, are more complex and usually modeled as controllable sources [13-17, 20]. The Interline Power Flow Controller (IPFC) is one of the voltage source converter(VSC) based FACTS Controllers which can effectively manage the power flow via multi-line Transmission System.

##### 4.2. FACTS Applications to Deregulated Electricity Market:

Nowadays, electricity demand is rapidly increasing without major reinforcement projects to enhance power transmission networks. Also, the electricity market is going toward open market and deregulation creating an environment for forces of competition and bargaining. FACTS devices can be an alternative

to reduce the flows in heavily loaded lines, resulting in an increased load ability, low system loss, improved stability of the network, reduced cost of production, and fulfilled contractual requirements by controlling the power flows in the network. Generally, the changing nature of the electricity supply industry is introducing many new subjects into power system operation related to trading in a deregulated competitive market. Commercial pressures on obtaining greater returns from existing assets suggests an increasingly important role for dynamic network management using FACTS devices and energy storage as an important resource in generation, transmission, distribution, and customer service. There has been an increased use of the FACTS devices applications in an electricity market having pool and contractual dispatches.

#### V. Applications and technical benefits of FACTS:

The technical benefits of the principal for dynamic applications of FACTS in addressing problems in transient stability, dampening, post contingency voltage control and voltage stability are summarized in Table-1. FACTS devices are required when there is a need to respond to dynamic (fast-changing) network conditions. The conventional solutions are normally less expensive than FACTS devices, but limited in their dynamic behavior. It is the task of the planners to identify the most economic solution[6].

	Load Flow Control	Voltage Control	Transient Stability	Dynamic Stability
SVC	•	•••	•	••
TCSC	••	•	•••	••
STATCOM	•	•••	••	••
SSSC	•	•••	••	••
UPFC	•••	•••	••	••

Table 1. Technical benefits of the main FACTS Devices.

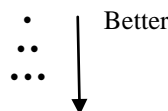

#### VI. Conclusion:

The essential features of FACTS controllers and their potential to improve system stability is the prime concern for effective & economic operation of the power system. The location and feedback signals used for design of FACTS-based damping controllers were discussed. The coordination problem among

different control schemes was also considered. Performance comparison of different FACTS controllers has been reviewed. The likely future direction of FACTS technology was discussed. In addition, utility experience and major real-world installations and semiconductor technology development have been summarized. A brief review of FACTS applications to optimal power flow and deregulated electricity market has been presented.

## References:

- [1] P.G.Burade and Dr.J.B.Helonde, "Optimal Location of FACTS Device on Enhancing System Security," *International Journal of Scientific and Engineering Research-France*, vol.3, issue.4, pp.1-8, 2012.
- [2] P.G.Burade and Dr.J.B.Helonde, "Optimal Placement of FACTS Device to Maximize the Loadability of Transmission Lines," *International Journal of Science and Engineering Investigations*, vol.1, issue.2, March.2012.
- [3] Bindeshwar Singh,"Introduction to FACTS Controllers in Wind Power Farms: A Technological Review INTERNATIONAL JOURNAL OF RENEWABLE ENERGY RESEARCH Bindeshwar Singh, Vol.2, No.2,2012.
- [4] V. Naresh Babu and S. Sivanagaraju, "A New Approach for Optimal Power Flow Solution Based on Two Step Initialization with Multi-Line FACTS Device" in *International Journal on Electrical Engineering and Informatics - Volume 4, Number 1, March 2012*.
- [5] Abu-Siada and Chatura Karunar "Improvement of Transmission Line Power Transfer Capability, Case Study" *Electrical and Electronics Engineering: An International Journal (EEEIJ) Vol.1, No.1, May 2012*.
- [6] Bindeshwar Singh, K. S. Verma, Deependra Singh, C.N.Singh, Archana Singh, Ekta Agrawal, Rahul Dixit And Baljiv Tyagi, "Introduction To Facts Controllers :A Critical Review" *International Journal of Reviews in Computing* 31st December 2011. Vol. 8 ISSN: 2076-3328, E-ISSN: 2076-3336.
- [7] P.G.Burade and Dr.J.B.Helonde," Mitigating Transmission Congestion and Enhanced ATC Using FACTS Device in the Deregulated Power Systems",*International Journal of Electrical Engineering*, Volume.4, pp.11-12, 2011.
- [8] Abdellatif Naceri, Habib Hamdaoui and Mohamed Abid "Advanced Fmrl Controller For Facts Devices To Enhance Dynamic Performance Of Power Systems" *International Journal Of Automation And Computing* 8(3), August 2011, pp.309-316.
- [9] Adepoju, G. A., Komolafe, O. A., "Analysis and Modelling of Static Synchronous Compensator (STATCOM): A comparison of Power Injection and Current Injection Models in Power Flow Study" in *International Journal of Advanced Science and Technology* Vol. 36, November, 2011.
- [10] Rolf Grünbaum, Ambra Sannino, Conny Wahlberg, ABB AB FACTS, Sweden, "Use of FACTS for enhanced flexibility and efficiency in power transmission and distribution grids.
- [11] Alisha Banga and S. S. Kaushik "Modelling and Simulation of SVC Controller for Enhancement of Power System Stability" *International Journal of Advances in Engineering & Technology*, July 2011. © IJAET ISSN: 2231-1963/79 Vol. 1, Issue 3, pp.79-84.
- [12] P.G Burade and Dr. J.B.Helonde, "Rescheduling of Generation to Relieve Congestion and Congestion Cost Allocation with FACTS Device," in *International Conference on Power, Control, Signal, and Computation, EPSCICON-2010*, IEEE Sponsored, Proceeding, vol.1, Thrissur-Kerala, Jan.2010, pp.134-140.
- [13] E. Acha, C. R. Fuerte-Esquivel, and H. Ambriz-Perez *et al.*, *FACTS: Modeling and Simulation in Power Networks*, London, U.K.: Wiley, 2004.
- [14] M. A. Abdel-Moamen and N. P. Padhy, "Optimal Power Flow Incorporating FACTS Devices Bibliography and Survey", *IEEE PES Transmission and Distribution Conference and Exposition*, 7-12 September 2003, vol. 2, pp. 669 - 676.
- [15] D. J. Hanson, M. L. Woodhouse, C. Horwill, D. R. Monkhouse, and M. M. Osborne, "STATCOM: A New Era of Reactive Compensation", *Power Engineering Journal*, June 2002, pp. 151-160.
- [16] T. S. Chung, D. Qifeng, Z. Bomina, "Optimal Active OPF with FACTS Devices by Innovative Load-Equivalent Approach", *IEEE Power Engineering Review*, **20(5)**(2000), pp. 63-66.
- [17] N. G. Hingorani and L. Gyugyi, *Understanding FACTS: Concepts and Technology of Flexible AC Transmission Systems*. New York: IEEE Press, 2000.
- [18] Yong Hua Song and Allan T. Johns, *Flexible AC Transmission Systems (FACTS)*. London, UK: IEE Press, 1999.
- [19] X. Dai, J. Liu, Y. Tang, N. Li, and H. Chen, "Neural Network nth-Order Inverse Control of Thyristor Controlled Series Compensator", *Electric Power Systems Research*, 45(1998), pp. 19-27.
- [20] D. J. Gotham and G. T. Heydt, "Power Flow Control and Power Flow Studies for Systems with FACTS Devices", *IEEE Trans. PWRs*, **13(1)**(1998), pp. 60-65.
- [21] N. G. Hingorani, "High Power Electronics and Flexible AC Transmission System", *IEEE Power Engineering Review*, July 1988 *on Power Systems*, 11(4)(1996), pp. 1937-1943.