

Multiphase Permanent Magnet Synchronous Motor Drive --- A Comparative Study”

Rohan M.Ingle*, Dr.S.B.Bodkhe**

*(Department of Electrical Engineering, Jhulelal Institute of Technology, RTM Nagpur University.

Email: rohan.ingle81@gmail.com)

** (Department of Electrical Engineering, RCOEM, RTM Nagpur University.

Email: s_b_bodkhe@yahoo.co.in)

ABSTRACT

Low frequency oscillations, high torque pulsation are a major disadvantage of three phase permanent-magnet motor configurations. Choosing the proper number of stator slots and winding distribution as well as increasing number of phases are among the possible solutions for reducing torque pulsation. In this research work, we propose to investigate the comparative performance of a Multi-Phase PMSM with different rotor topologies by Finite Element Analysis (FEA), Modelling & Simulation using MATLAB. This will be verified by practical fabrication and testing . Also our research develops a guideline regarding selection of appropriate rotor construction of PMSM to meet different types of load characteristics. Some of the following issues shall be addressed while doing so. This type of work is not found in literature. It will help in selection of appropriate topology of the machine for various applications.

Keywords : PMSM, FEA, MATLAB Simulink, Sensor.

I. INTRODUCTION

Permanent magnet Synchronous motors (PMSM) are different from the wound field Synchronous motors. However the stator structure of PMSM is similar to wound field Synchronous motor, the difference is only between rotor structures. Field of PMSM is created by permanent magnets placed on the rotor, hence they are also called as brushless motors. Since they are brushless, Permanent magnet Synchronous motors are more robust than DC motors. Since field is created by Permanent magnet, these motors are more efficient than Induction motors. PMSM motors are widely used in industrial servo-applications due to its high-performance characteristics. PMSM have gained an increasing attention due to their high torque to inertia ratio, higher efficiency & power density.

II. MULTIPHASE MACHINES

Multi-phase machines can be used as an alternative to multi-level converters. In multi-phase machines, by dividing the required power between multiple phases, more than the conventional three, higher power levels can be obtained and power electronic converters with limited power range can be used to drive the multi-phase machine. Insulation level is one of the limiting factors that can prohibit the use of high voltage systems. Therefore, multi-phase machines that employ converters operating at lower voltage level are preferred. Multiphase motor drives posses many other advantages over the traditional

three-phase motor drives such as reducing the amplitude and increasing the frequency of torque pulsation, reducing the stator current per phase without increasing the voltage per phase, lowering the dc link current harmonics and higher reliability. By increasing the number of phases it is also possible to increase the torque per rms ampere for the same volume machine. The additional degrees of freedom in multi phase system also enable us to inject harmonic currents or supply multi motors from a single inverter [5].

III. MULTIPHASE PMSM

To increase the driving comfortableness and reliability of electric vehicles, multi-phase PMSM are promisingly used. Multiphase motors have high power density, high efficiency, reduced torque pulsation, these features are suitable for modern electric drive applications which are energy efficient in variable speed operation under weight and volume control [1]. The additional degrees of freedom in multi phase system also enable to inject harmonic currents or supply multi motors from a single inverter. In multi-phase machines, by dividing the required power between multiple phases, more than the conventional three, higher power levels can be obtained. Power electronic converters with limited power range can be used to drive the multi-phase machine.3.1 Unique Features Over Traditional Three-Phase PMSMBy increasing the number of phases, in multiple PMSM it is possible to increase the torque/ rms ampere [5].

- Lowering the DC link current harmonics and higher reliability.
- The additional degrees of freedom in multi phase system also enable us to inject harmonic currents or supply multi motors from a single inverter.
- Ability to limit Short circuit current between phases.
- Ability to limit short circuit conditions between turns.
- Complete Physical isolation between phases and effective thermal isolation .
- Complete Electric Isolation and effective magnetic isolation.

III. DIFFERENT TYPES OF STATOR TOPOLOGIES.

Salient Pole or Solenoidal – winding construction
Short end turns windings are formed around individual poles. having less coupling between the phases. Each phase winding does not interact simultaneously with all rotor magnets which lead to lower performance. Variation in airgap permeance for reducing cogging torque [10].

Slot less Construction

Eliminating slots & distributing the stator windings minimizes cogging torque. More space required for windings because the thermal conductivity between the windings & back of the stator iron is much lower. No stator teeth, hence increase airgap length which is equal to distance from the rotor surface to the stator back iron.

IV. DIFFERENT TYPES OF ROTOR TOPOLOGIES.

Merrill's rotor-Classical configuration

The laminated external ring has deep narrow slots between individual permanent magnet poles [10]. The leakage flux produced by the permanent magnet can be adjusted by changing the width of the narrow slots. The permanent magnet is mounted on the shaft with the aid of an aluminum or zinc alloy sleeve.

Surfaces-Magnet Rotor

Permanent Magnet are mounted on outer surface of rotor The surface magnet motor can have magnets magnetized radially or sometimes circumferentially. An external high conductivity non-ferromagnetic cylinder is sometimes used. It protects the PMs against the demagnetizing action of armature reaction and centrifugal forces, provides an asynchronous starting torque, and acts as a damper

Interior-Magnet PMSM

In this type, Permanent Magnets are buried inside the rotor. The interior-magnet rotor has radially magnetised and alternately poled magnets.

Because the magnet pole area is smaller than the pole area at the rotor surface, the air gap flux density on open circuit is less than the Flux density in the magnet. The magnet is very well protected against centrifugal forces. Such a design is recommended for high frequency high speed motors.

V. CONVERSION OF A THREE-PHASE MACHINE INTO A FIVE-PHASE MACHINE

To convert the three-phase machine into a more efficient five-phase one, it is necessary to find a new fractional slot winding that fulfills the following conditions: The average torque must be satisfied for both machines. The time constants of both elementary machines must be compatible with the PWM frequency. The third harmonic winding factor must be as high as possible in order to enable the second machine to provide a significant torque. The cogging torque should not be increased when using the new pole-slot configuration.

VI. PERMANENT MAGNET SYNCHRONOUS MOTOR DRIVE SYSTEM

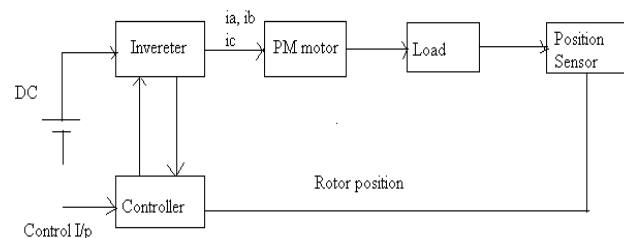

Fig.1 Block diagram of PMSM drive system

PM motor drive consists Permanent magnet Synchronous motor, Inverter, Controller & Position sensor. Operation of permanent magnet synchronous motors requires position sensors in the rotor shaft when operated without damper winding. The need of knowing the rotor position requires the development of devices for position measurement [2]. There are four main devices for the measurement of position, the potentiometer, linear variable differential transformer, optical encoder and resolvers. The ones most commonly used for motors are encoders and revolvers. Depending on the application and performance desired by the motor a position sensor with the required accuracy can be selected. Voltage Source Inverters are devices that convert a DC voltage to AC voltage of variable frequency and magnitude. They are very commonly used in adjustable speed drives and are characterized by a well defined switched voltage wave form. The devices list with their respective power switching capabilities are shown in table below MOSFETs and IGBTs are

preferred by industry because of the MOS gating permits high power gain and control advantages.

7.1 Permanent Magnet Synchronous Motor Drive during Speed Regulation

The control system consists of a speed feedback system, a motor, an inverter, a controller and a speed setting device. A properly designed feedback controller makes the system insensible to disturbance and changes of the parameters. The purpose of a motor speed controller is to take a signal presenting the demanded speed, and to drive a motor at that speed. Closed Loop speed control systems have fast response, but become expensive due to the need of feed back components such as speed sensors.

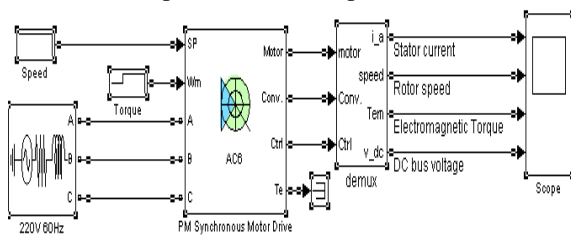
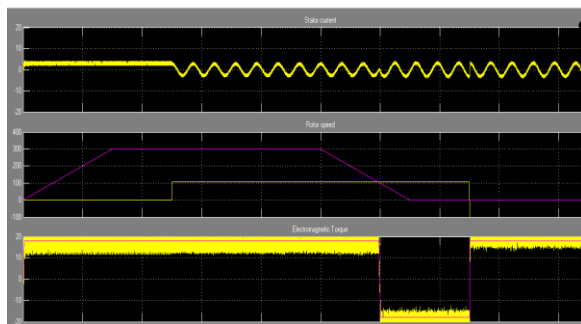

Fig. 2 matlab model for verifying characteristics

Specifications Of PMSM

Mechanical input = Speed, Resistance + 0.2 ohms, D-axis, Inductance = 0.008 H, Q- axis inductance = 0.0085 H, Pole Pairs = 8, Flux induced by magnets = 0.5 wb, Source frequency = 50 Hz, Inverter switching by IGBT

Simulation for Operation at 300 rad/s



At same speed having 21 pole pairs, flux = 0.1wb.

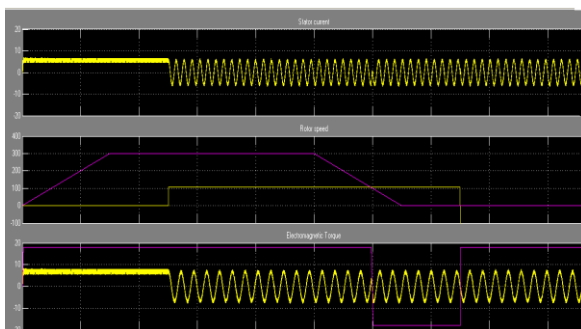

Fig.3 Simulation results for 3-phase with different construction criterion

In the present simulation measurement of currents and voltages in each part of the system is possible, thus permitting the calculation of instantaneous or average losses, efficiency of the drive system and total harmonic distortion. For same motor, if mechanical input is torque, low frequency oscillations were observed in stator current & torque. As my interest in multiphase with higher pole pairs, stator current will be a important factor for observing torque. Also flux linkages by magnet in traditional three phase & multiphase affects stator current & torque maintaining same voltage.

VII. DESIGN APPROACH FOR FIVE-PHASE PMSM MACHINES

Criteria to improve the torque density of a five-phase machine with references to a three-phase machine. To find a simple condition that ensures a torque density improvement when the phase number is changed from three to five, with the assumption of a perfect sinusoidal current. These two machines are assumed to have the same main geometrical specifications (same diameter) and to run with the same current density, same linear load. & same active copper losses. Criteria based on the harmonic property of the multi-phase machines. The five phases are identical and regularly shifted. Saturation and damper windings are neglected. The back back-EMF in the stator windings is not disturbed by the stator currents.

Features of Five-Phase PMSM.

High torque to inertia ratio and power density. These motors are built with strong magnetic material like Samarium Cobalt and Neodymium Iron Boron. Better short-time overload capability than Induction motors. Application of five-phase PMSM for low speed operation in direct drives is an economic alternative for Induction motors. Synchronous motor is made for better fault tolerant capability. Overcome major failures such as open circuit of single or two phases and short circuit of one phase. In high speed application, five-phase PMSM has an extended flux weakening region because of their reluctance torque and ruggedness of rotor. Proper rotor design is one of the best way to minimize torque pulsation in multi-phase PMSM drive. The five-phase PMSM motors are simple to manufacture and easy to installation.

MODELING OF PMSM

The dynamic model of the permanent magnet synchronous machine (PMSM) is derived using a two-phase motor indirect and quadrature axes. This approach is done because of the conceptual simplicity obtained with only one set of two windings on the stator. The rotor has no windings, only magnets. The

magnets are modelled as a current source or a flux linkage source, concentrating all its flux linkages along only one axis. Constant inductance for windings is obtained by a transformation to the rotor by replacing the stator windings with a fictitious set of d-q windings rotating at the electrical speed of the rotor [3]. The equivalence between the three-phase machine and its model using a set of two-phase windings is derived and this approach is suitable for extending it to model an n phase machine where n is greater than 2, with a two-phase machine. Derivations for electromagnetic torque involving the currents and flux linkages are obtained. The differential equations describing the PMSM are nonlinear.

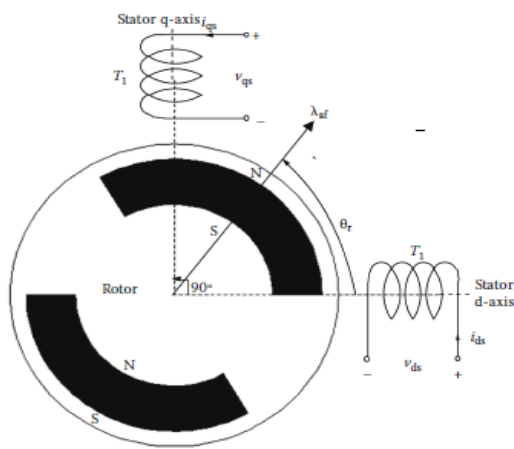

Fig.4. Dynamic model of PMSM

The windings are displaced in space by 90 electrical degrees and the rotor winding is at an angle θ_r from the stator d axis winding. It is assumed that the q-axis leads the d-axis to a counter clockwise direction of rotation of the rotor. A pair of poles is assumed for this figure, but it is applicable with slight modification for any number of pairs of poles [3]. [Note that θ_r is the electrical rotor position at any instant obtained by multiplying the mechanical rotor position by pairs of electrical poles. The d- and q-axes stator voltages are derived as the sum of the resistive voltage drops and the derivative of the flux linkages in the respective windings as

$$V_{qs} = R_q i_{qs} + p \lambda_{qs} \quad (1)$$

$$V_{ds} = R_d i_{ds} + p \lambda_{ds} \quad (2)$$

where - p is the differential operator, d/dt v_{qs} and v_{ds} are the voltages in the q- and d-axes windings i_{qs} and i_{ds} are the q- and d-axes stator currents R_q and R_d are the stator q- and d-axes resistances λ_{qs} and λ_{ds} are the stator q- and d-axes stator flux linkages [6]. The stator winding flux linkages can be written as the sum of the flux linkages due to their own excitation and mutual flux linkages

resulting from other winding current and magnet sources. The q and d stator flux linkages are written as

$$Y_{qs} = L_{qq} i_{qs} + L_{qd} i_{ds} + \lambda_{af} \sin \theta_r \quad (3)$$

$$Y_{ds} = L_{dq} i_{qs} + L_{dd} i_{ds} + \lambda_{af} \cos \theta_r \quad (4)$$

Where θ_r is the instantaneous rotor position. The windings are balanced and therefore their resistances are equal and denoted as $R_s = R_q = R_d$.

The d and q stator voltages can then be written in terms of the flux linkages and resistive voltage drops as

$$V_{qs} = R_s i_{qs} + i_{qs} p L_{qq} + L_{qq} p i_{qs} + L_{qd} p i_{ds} + i_{ds} p L_{qd} + \lambda_{af} p \sin \theta_r \quad (5)$$

$$V_{ds} = R_s i_{ds} + i_{ds} p L_{dd} + L_{dd} p i_{ds} + L_{dq} p i_{qs} + i_{qs} p L_{dq} + \lambda_{af} p \cos \theta_r \quad (6)$$

L_{qq} and L_{dd} are the self-inductances of the q- and d-axes windings, respectively [18]. The mutual inductances between any two windings are denoted by L with two subscripts where the first subscript denotes the winding at which the emf is measured due to the current in the other winding indicated by the second subscript. The symmetry of the q- and d-axes windings ensures that L_{qd} and L_{dq} are equal. Substituting the self- and mutual inductances in terms of the rotor position into the stator voltage equations will result in a large number of terms that are rotor position dependent. The final machine equations then are

$$\begin{bmatrix} V_{qs} \\ V_{ds} \end{bmatrix} = R_s \begin{bmatrix} i_{qs} \\ i_{ds} \end{bmatrix} + \begin{bmatrix} L_1 & 0 \\ 0 & L_2 \end{bmatrix} \frac{d}{dt} \begin{bmatrix} i_{qs} \\ i_{ds} \end{bmatrix} + \lambda_{af} \omega_r \begin{bmatrix} \cos \theta_r \\ -\sin \theta_r \end{bmatrix} \quad 7$$

Transformation To Rotor Reference Frames

Reference frames gives a unique view of the system and dramatic simplification of the system equations. The independent rotor field position determines the induced emf and affects the dynamic system equations of both the wound rotor and the PMSMs. The fictitious stator will have the same number of turns for each phase as the actual stator phase windings and should produce the equivalent mmf. The actual stator mmf in any axis (say q or d) is the product the number of turns and current in the respective axis winding. It is equated, respectively, to the mmf produced by the fictitious stator windings on the q- and d-axes. Similarly, the same procedure is repeated for the d-axis of the actual stator winding. This leads to a cancellation of the number of turns on both sides of the q- and d-axes stator mmf equations, resulting in a relationship between the actual and fictitious stator currents. The relationship between the currents in the stationary reference frames and the rotor reference frames currents is written as

$$i_{qds} = [T] i_{rqds}$$

and similarly voltage relation is given as

$$v_{qds} = [T] v_{rq ds}$$

where T is transition matrix

The PMSM model in rotor reference frames is obtained as

$$\begin{bmatrix} V_{qds} \\ V_{dqs} \end{bmatrix} = \begin{bmatrix} R_s + L_{\sigma p} & \omega_r L_d \\ -\omega_r L_q & R_s + L_{\sigma p} \end{bmatrix} \begin{bmatrix} i_{qds} \\ i_{dqs} \end{bmatrix} + \begin{bmatrix} \omega_r \lambda_{af} \\ 0 \end{bmatrix}$$

Where ω_r is the rotor speed in electrical radians per second. This equation is in a form where the voltage vector is equal to the product of the impedance matrix and the current vector, with an additional component due to the motional emf of the rotor flux linkages.

9.2 Electromagnetic Torque

The electromagnetic torque is the most important output variable that determines the mechanical dynamics of the machine such as the rotor position and speed. It is derived from the machine matrix equation by looking at the input power and its various components such as resistive losses, mechanical power, and the rate of change of stored magnetic energy [18]. Hence, the output power is the difference between the input power and the resistive losses in a steady state. The dynamic equations of the PMSM can be written as

$$V = [R] i + [L] p i + [G] \omega_r i \quad (8)$$

By pre multiplying Equ.(8) by the transpose of the current vector, the instantaneous input power is

$$P_i = i^T V = i^T [R] i + i^T [L] p i + i^T [G] \omega_r i \quad (9)$$

Where [R] matrix consists of resistive elements [L] matrix consists of the coefficients of the derivative operator p, [G] matrix has elements that are the coefficients of the electrical rotor speed, θ_r . The term $i^T [R] i$ gives stator and rotor resistive losses. The term $i^T [L] p i$ denotes the rate of change of stored magnetic energy. The air gap power is the product of the mechanical rotor speed and air gap or electromagnetic torque. Hence, the air gap torque, T_e , is derived from the terms involving the rotor speed, ω_m , in mechanical rad/s, as

$$\omega_m T_e = P_a = i^T [G] i \quad \omega_r = i^T [G] i \quad P/2 \quad \omega_m \quad (10)$$

Where P is the number of poles. Cancelling speed on both sides of the equation leads to an electromagnetic torque that is Substituting [G] in Equ.(11) the electromagnetic torque is obtained as

$$T_e = (3/2)(P/2) [y_{af} + (L_d - L_q) i_{dr}^f] i_{qr}^f \quad (N.m) \quad (12)$$

$$T_e = (P/2) i^T [G] i \quad (11)$$

Three phase supply of $V_{rms} = 220V$, $f = 50$ Hz is provided as supply. Using Parks Transformation three phase is transformed into two phase for ease of modelling. Parks Transformation give Direct axis(d), Quadrature axis(q) and zero-sequence currents. Zero sequence currents are terminated.

Current Sub system:

The stator currents i_q, i_d are derived by state space model and these are represented in the subsystems as shown in the fig

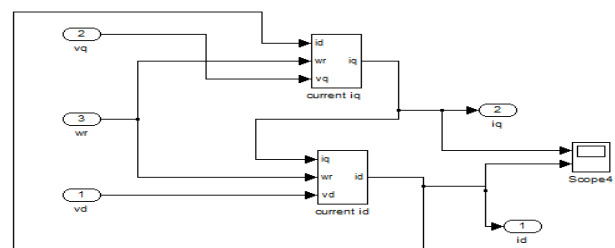

Fig.5. i_d, i_q current blocks

Speed Sub model:

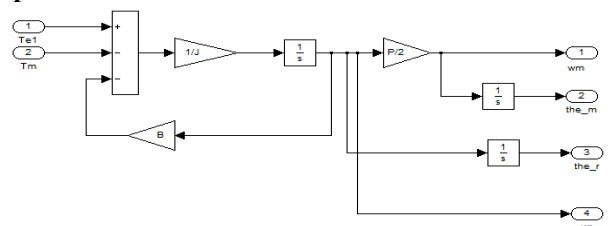

Fig.6. Speed model blocks

Torque sub model

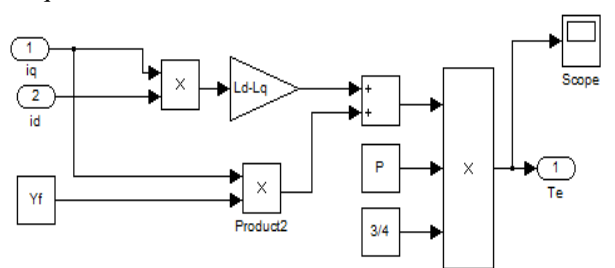

Fig.7. Torque model blocks of PMSM

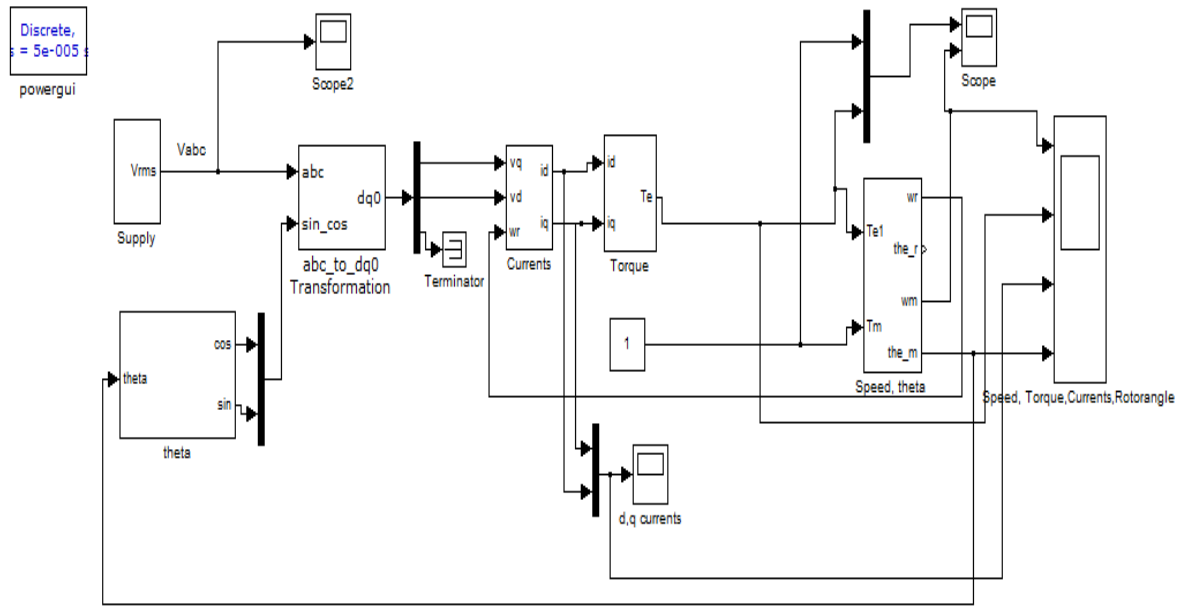

Fig 8. Simulink model of Permanent Magnet Synchronous Motor

The motor simulation is carried out for with values Stator Resistance $R_s = 1.2\text{ohm}$, $B = 4.6752e-5 \text{ kg/m}^2$, $J = 2.0095e-5 \text{ Nms}$, Stator Resistance = 2.0357ohm , Direct axis inductance(L_d) = $7.8e-3 \text{ H}$, Quadrature axis Inductance(L_q) = $7.8e-3 \text{ H}$, flux = 0.154 V s , Poles=4, $V_{rms} = 220\text{v}$.

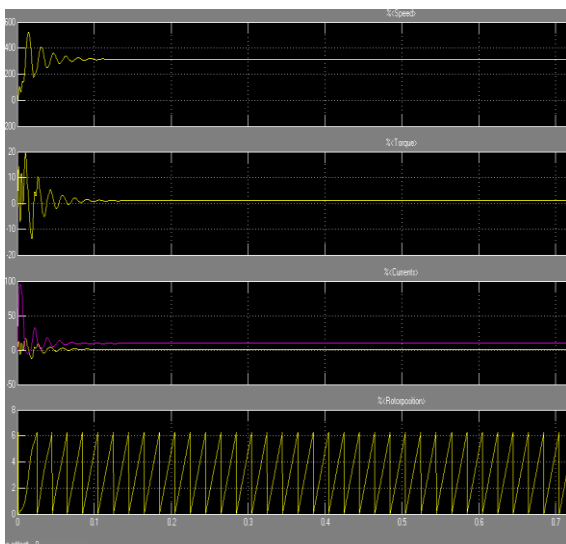

Fig 9 Simulink results

X. CONCLUSION

In this research work, we propose to investigate the comparative performance of a Multi-Phase PMSM with different rotor

topologies by Finite Element Analysis (FEA). This will be verified by practical fabrication and testing. Some of the following issues shall be addressed while doing so. This type of work is not found in literature. It will help in selection of appropriate topology of the machine for various applications. Initially in multiphase machine, we are investigate five phase PMSM with different rotor topologies, its modeling with respect to different parameters and analysis by simulation, & Finite Element Method.

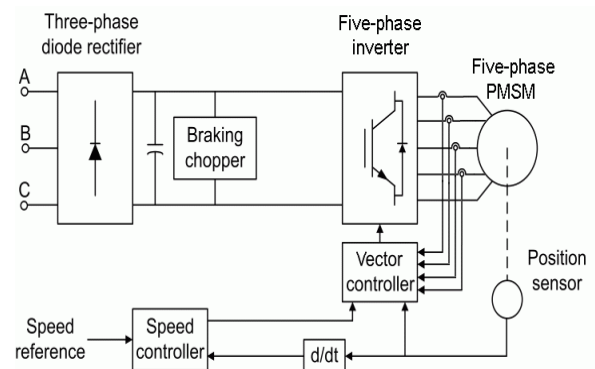

Fig 10. Proposed five phase PMSM modeled block diagram

REFERENCES

Journal Papers:

- [1] N. Levin, S. Orlova, V. Pugachov, B. Ose-Zala, E. Jakobsons "Methods to Reduce the Cogging Torque in Permanent Magnet synchronous Machines" *ELEKTRONIKA IR ELEKTROTECHNIKA*, ISSN 1392-1215, VOL. 19, NO. 1, 2013.

- [2] S. Ashok Subramanian , M. Murugan “Torque Ripple Minimizing of Pmsm Using Improved Hysteresis Controller ” *IOSR Journal of Engineering (IOSRJEN)* e-ISSN: 2250-3021, p-ISSN: 2278-8719 Vol. 3, Issue 7 (July. 2013), ||V2 || PP 05-12
- [3] M.J. Soleimani Keshayeh, S. Asghar Gholamian “Optimum Design of a Three-Phase PermanentMagnet Synchronous Motor for industrial applications” *International Journal of Applied Operational Research*, Vol. 2, No. 4, pp. 67-86, Winter 2013.
- [4] Mohamed Kadjoudj, Soufiane Taibi, Noureddine Golea, Hachemi Benbouzid, Modified Direct Torque Control of Permanent Magnet Synchronous Motor Drives, *International Journal of Sciences and Techniques of Automatic control & computer engineering IJ-STA*, Volume 1, N° 2, Dec 2007, pp. 167–180.
- [5] G.Fabri, C.Olivieri and M.Tursini , “Observer-based Sensorless Control of a Five-phase Brushless DC Motor” , *XIX International Conference on Electrical Machines- ICEM 2010*, Rome.
- Proceedings Papers:**
- [6] P. Sergeant, F. D. Belie and J. Melkebeek, “Rotor Geometry Design of Interior PMSMs With and Without Flux Barriers for More Accurate Sensorless Control,” *IEEE Trans. Ind. Electron.*, vol. 59, no. 6, pp. 2457–2465, June 2012
- [7] Enping Cao, Barrie C Mecrow, Overview of Electric motor Technologies Used for More *Electric Aircraft(MEA)*, *IEEE TRANSACTIONS ON INDUSTRIAL ELECTRONICS*, Vvol.No.59, SEPTEMBER 2012.
- [8] Yong-Cheol Kwon, Sungmin Kim and Seung –Ki Sui, “Voltage Feedback Current Control Scheme for Improved Transient Performance of Permanent Magnet Synchronous Machine Drives” *IEEE Transactions on Industry Applications*, Vol-59. NO.9. SEPTEMBER 2012.
- [9] P. Sergeant, F. D. Belie and J. Melkebeek, “Rotor Geometry Design of Interior PMSMs With and Without Flux Barriers for More Accurate Sensorless Control,” *IEEE Trans. Ind. Electron.*, vol. 59, no. 6, pp. 2457–2465, June 2012..
- [10] A. Accetta, M. Cirrincione, M. Pucci and G. Vitale, “Sensorless Control of PMSM Fractional Horsepower Drives by Signal Injection and Neural Adaptive-Band Filtering,” *IEEE Trans. Ind. Electron.*, vol. 59, no. 03, pp. 1355–1366, March 2012.
- [11] A. Accetta, M. Cirrincione, M. Pucci and G. Vitale, “Sensorless Control of PMSM Fractional Horsepower Drives by Signal Injection and Neural Adaptive-Band Filtering,” *IEEE Trans. Ind. Electron.*, vol. 59, no. 03, pp. 1355–1366, March 2012.
- [12] A. Accetta, M. Cirrincione, M. Pucci and G. Vitale, “Sensorless Control of PMSM Fractional Horsepower Drives by Signal Injection and Neural Adaptive-Band Filtering,” *IEEE Trans. Ind. Electron.*, vol. 59, no. 03, pp. 1355–1366, March 2012.
- [13] Yong-Cheol Kwon, Sungmin Kim and Seung –Ki Sui, “Voltage Feedback Current Control Scheme for Improved Transient Performance of Permanent Magnet Synchronous Machine Drives” *IEEE Transactions on Industry Applications*, Vol-59. NO.9. SEPTEMBER 2012.
- [14] R. Leidhold, “Position sensorless control of PM Synchronous Motors Based on Zero-Sequence Carrier Injection,” *IEEE Trans. Ind. Electron.*, vol. 58, no. 12, pp. 5371–5379, Dec. 2011.
- [15] P.Zheng, Y.Sui, J.Zhao, C.Tong, T.A.Lipoand A.wang “Investigation of a Novel Five-Phase Modulator Permanent magnet In –wheel motor” *IEEE Transactions on Magnetics*, Vol.47,NO.10.10 OCT2011.
- [16] Leila Persa, Hamid A. Toliyat , “Sensorless direct Torque Control of Five-phase Interior permanent Magnet Motor Drives” *IEEE Transactions on Industry Applications*, Vol-43,NO.4,JULY/AUGUST 2007.
- [17] Leila Parsa, and Hamid A. Toliyat, “Five – Phase Permanent –Magnet Motor drives” *IEEE Transactions on Industry Applications*, Vol-41,NO.1,JAN/FEB 2005.
- Book:**
- [18] R. Krishnan, *Electric Motor Drives Modeling, Analysis, and Control*, Pearson Education, 2001.
- Theses:**
- [19] J. Rais, M. P. Donsión, “Permanent Magnet Synchronous Motors (PMSM). Parameters influence on the synchronization process of a PMSM”.