

Jamming aware Traffic Allocation in Wireless Mesh Network for Multiple Path Routing using Portfolio Selection

Sagar P. Tete*, Prof. Vaidehi Baporikar**

*(Department of Information Technology, Yeshwantrao Chavan College of Engineering, Nagpur,

** (Department of Information Technology, Yeshwantrao Chavan College of Engineering, Nagpur,

ABSTRACT-

In wireless mesh network many problems encountered we present a jamming aware traffic allocation in single path as well as multiple path routing. In this paper we observed and consider jamming problem for traffic allocation from source to destination i.e. based on non experience traffic jammed on any network node. We distribute this traffic allocation in lossy network flow optimization problem using portfolio selection theory from financial statistics. We also show multisource traffic allocation from source to destination, this centralized optimization problem can be solved using a distributed algorithm based on decomposition in network utility maximization. We demonstrate the network ability to estimate the impact of jamming, effect of jammer in network, end to end packet success rate and overall network throughput in network. Finally we show the achievable throughput using network simulator.

Keywords - effect of Jammer Mobility on Network, jamming, multiple-path routing, packet Success rates, and performance evaluation.

I. INTRODUCTION

In the field of wireless technology, we have face various problem that are encountered in day to day life we focus on jamming, conjunction in network and how to tackle all these activity in network traffic allocation. There are several antijamming techniques and defensive technique to avoid the jammer activity incorporate into higher level protocol, for example channel surfing or routing around jammed regions of the network.

The major antijamming techniques used diversity (different best path) For example; antijamming protocols may employ multiple frequency bands, different MAC channels, or multiple routing paths. Such diversity techniques help to curb the effects of the jamming attack by requiring the jammer to act on multiple resources simultaneously. In this paper, we consider the anti-jamming diversity based on the use of multiple routing paths. Using multiple-path variants of source routing protocols such as Dynamic Source Routing (DSR) or Ad-Hoc On-Demand Distance Vector (AODV), for example the MPDSR protocol, each source node can request several routing paths to the destination node for concurrent use. To make effective use of this routing diversity, however, each source node must be able to make an intelligent allocation of traffic across the available paths while considering the potential effect of jamming on the resulting data throughput.

In order to characterize the effect of jamming on throughput, each source must collect

information on the impact of the jamming attack in various parts of the network. However, the extent of jamming at each network node depends on a number of unknown parameters, including the strategy used by the individual jammers and the relative location of the jammers with respect to each transmitter-receiver pair.

In this paper, we thus investigate the ability of network nodes to characterize the jamming impact and the ability of multiple source nodes to compensate for jamming in the allocation of traffic across multiple routing paths.

Figure below show the how jammer disturb the communication and brake there transmission of there packets to different node that are connected to

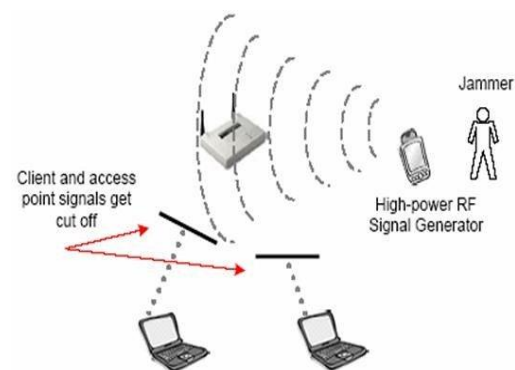

the network.

Fig.1.example of jammer effect for several nodes.

II. NETWORK MODEL AND ASSUMPTIONS

The wireless mesh network we represent the directed graph and have several vertices to represent the node we designed two nodes as source and two nodes as destination to formed connection between them.

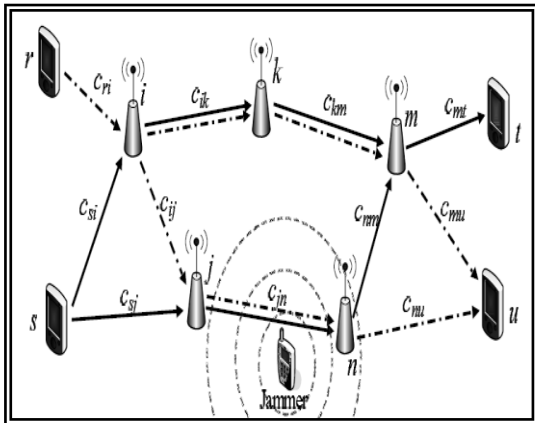

Fig.2.example of network with source(r, s) along with destination (t, u).

In this paper, we assume that the source nodes in have no prior knowledge about the jamming attack being performed. That is, we make no assumption about the jammer's goals, method of attack, or mobility patterns. We assume that the number of jammers and their locations are unknown to the network nodes. Instead of relying on direct knowledge of the jammers, we suppose that the network nodes characterize the jamming impact in terms of the empirical packet delivery rate. Network nodes can then relay the relevant information to the source nodes in order to assist in optimal traffic allocation. Each time a new routing path is requested or an existing routing path is updated.

III. ALLOCATION OF TRAFFIC ACROSS MULTIPLE ROUTING PATHS

We create simple network along with five nodes to form a simple traffic allocation on network then multiple path network to transfer packet from source to destination.

We formulate the problem of allocating traffic across multiple routing paths in the presence of jamming as a lossy network flow optimization problem.

We design network of several node to observe the packet flow from source to there destination to estimate the effect of jammer and characterized impact of jammer.

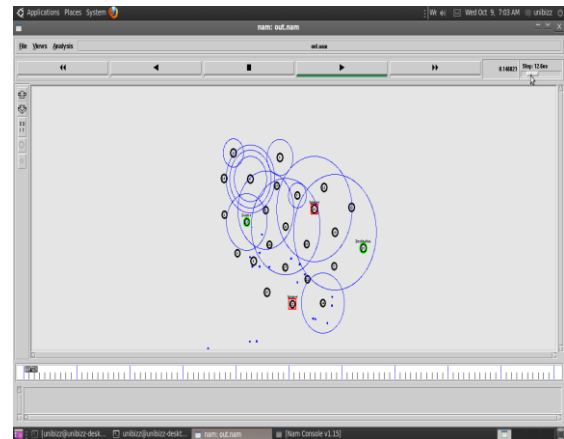

Fig. 3. Snapshot of multiple path routing of packet.

IV. CHARECTERIZING THE IMPACT OF JAMMING

In this Module, network nodes to estimate and characterize the impact of jamming and for a source node to incorporate these estimates into its traffic allocation. In order for a source node s to incorporate the jamming impact in the traffic allocation problem, the effect of jamming on transmissions over each link must be estimated.

However, to capture the jammer mobility and the dynamic effects of the jamming attack, the local estimates need to be continually updated.

Fallowing section we discuss on effect of jammer mobility on network and estimating end to end packet success rate using single source network with several paths.

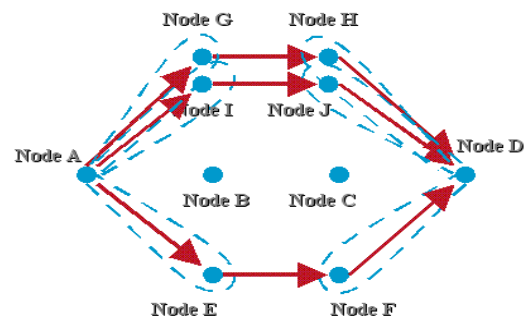

Fig. 4. Illustrates a single-source network with three routing paths.

4.1 Effect Of Jammer Mobility On Network

Fig 4 illustrates a single-source network with three routing paths $p_1 = \{(A, G), (G, H), (H, D)\}$, $p_2 = \{(A, I), (I, J), (J, D)\}$ and $p_3 = \{(A, E), (E, C), (C, D)\}$.

The label on each edge (i, j) is the link capacity c_{ij} indicating the maximum number of packets per second (pkts/s) which can be transported over the wireless link. In this example, we assume that the source is generating data at a rate of 300 pkts/s. In the

absence of jamming, the source can continuously send 100 pkts/s over each of the three paths, yielding a throughput rate equal to the source generation rate of 300 pkts/s. If a jammer near node G is transmitting at high power, the probability of successful packet reception, referred to as the packet success rate, over the link (A, G) drops to nearly zero, and the traffic flow to node D reduces to 200 pkts/s. If the source node becomes aware of this effect, the allocation of traffic can be changed to 150 pkts/s on each of paths p2 and p3, thus recovering from the jamming attack at node G. However, this one-time re-allocation by the source node A does not adapt to the potential mobility of the jammer. If the jammer moves to node y, the packet success rate over (A, G) returns to one and that over (A, I) drops to zero, reducing the throughput to node d to 150 pkts/s, which is less than the 200 pkts/s that would be achieved using the original allocation of 100 pkts/s over each of the three paths. Hence, each node must relay an estimate of its packet success rate to the source node s and the source must use this information to reallocate traffic in a timely fashion if the effect of the attack is to be mitigated. The relay of information from the nodes can be done periodically or at the instants when the packet success rates change significantly. These updates must be performed at a rate comparable to the rate of the jammer movement to provide an effective defence against the mobile jamming attack. Next, suppose the jammer continually changes position between nodes G and y, causing the packet success rates over links (A, G) and (A, I) to oscillate between zero and one. This behaviour introduces a high degree of variability into the observed packet success rates, leading to a less certain estimate of the future success rates over the links (A, G) and (A, I). However, since the packet success rate over link (A, E) has historically been steadier, it may be a more reliable option. Hence, the source s can choose to fill p3 to its capacity and partition the remaining 100 pkts/s equally over p1 and p2. This solution takes into account the historic variability in the packet success rates due to jamming mobility.

4.2 Estimating End To End Packet Success Rate

Estimating End-to-End Packet Success Rates are obtain on graphical representation of simulated result, The packet success rate estimates for the links in a routing path, the source needs to estimate the effective end-to-end packet success rate to determine the optimal traffic allocation. Assuming the total time required to transport packets from each source s to the corresponding destination is negligible compared to the update relay period.

V. PERFORMANCE EVALUATION

In this section, we simulate various aspects of the proposed techniques for estimation of jamming impact and jamming-aware traffic allocation. We obtain several result on graph after simulation, first to estimate the packet success rate to each node using packet delivery ratio from each node with jammer without jammer, second is to estimate end to end delay to increase reliability of our network traffic flow and finally efficiently allocate the traffic to maximize the overall throughput in network and We observe that simulation result is better than previous result while ignoring jammer we reduce packet loss and increase throughput in network.

Following graph shows our experimental work with jammer and ignoring jammer, we obtain comparative results firstly packet delivery ratio, end to end delay and overall throughput in network from source to destination.

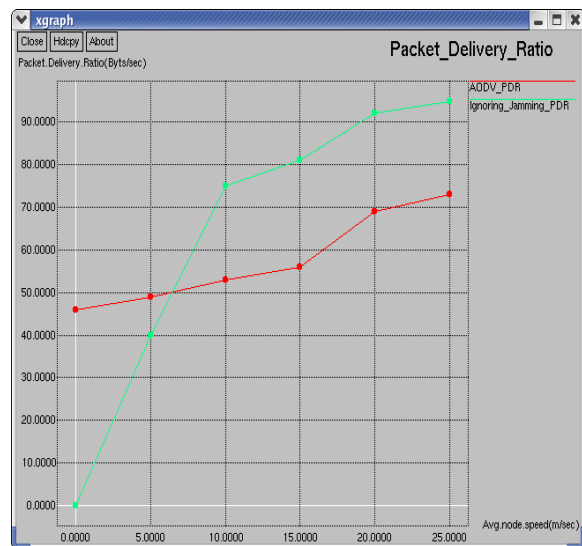

Graph1: packet delivery ratio.

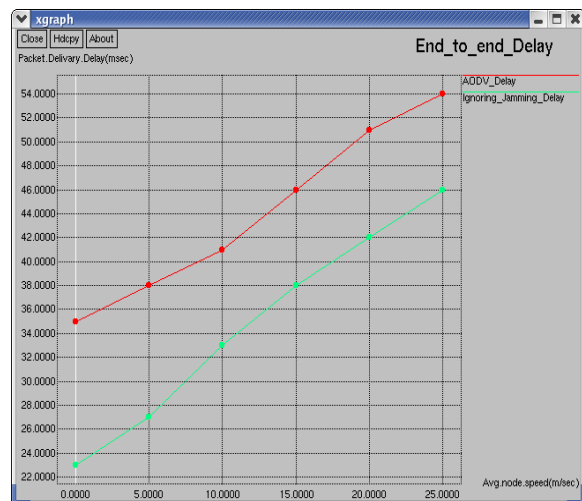

Graph2: end to end delay

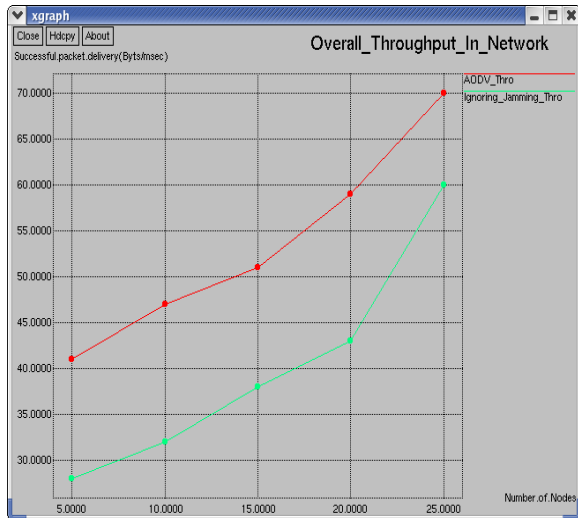

Graph3: overall throughput in network

VI. CONCLUSIONS

We studied the problem of traffic allocation in multiple-path routing in the presence of jammers whose effect can only be characterized statistically. We formulated multiple-path traffic allocation in multisource networks as a lossy network flow optimization. We have thus shown that multiple-path source routing can optimize the throughput performance by effectively incorporating the empirical jamming impact into the allocation of traffic to the set of paths. We presented simulation results using network simulator.

REFERENCES

- [1] I. F. Akyildiz, X. Wang, and W. Wang, "Wireless mesh networks: A survey," *Comput. Netw.*, vol. 47, no. 4, pp. 445–487, Mar. 2005.
- [2] E. M. Sozer, M. Stojanovic, and J. G. Proakis, "Underwater acoustic networks," *IEEE J. Ocean. Eng.*, vol. 25, no. 1, pp. 72–83, Jan. 2000.
- [3] R. Anderson, *Security Engineering: A Guide to Building Dependable Distributed Systems*. New York: Wiley, 2001.
- [4] J. Bellardo and S. Savage, "802.11 denial-of-service attacks: Real vulnerabilities and practical solutions," in *Proc. USENIX Security Symp.*, Washington, DC, Aug. 2003, pp. 15–28.
- [5] D. J. Thunte and M. Acharya, "Intelligent jamming in wireless networks with applications to 802.11 b and other networks," in *Proc. 25th IEEE MILCOM*, Washington, DC, Oct. 2006, pp. 1–7.
- [6] A. D. Wood and J. A. Stankovic, "Denial of service in sensor networks," *Computer*, vol. 35, no. 10, pp. 54–62, Oct. 2002.
- [7] G. Lin and G. Noubir, "On link layer denial of service in data wireless LANs," *Wireless Commun. Mobile Comput.*, vol. 5, no. 3, pp. 273–284, May 2005.
- [8] W. Xu, K. Ma, W. Trappe, and Y. Zhang, "Jamming sensor networks: Attack and defense strategies," *IEEE Netw.*, vol. 20, no. 3, pp. 41–47, May/Jun. 2006.
- [9] D. B. Johnson, D. A. Maltz, and J. Broch, *DSR: The Dynamic Source Routing Protocol for Multihop Wireless Ad Hoc Networks*. Reading, MA: Addison-Wesley, 2001, ch. 5, pp. 139–172.
- [10] E. M. Royer and C. E. Perkins, "Ad hoc on-demand distance vector routing," in *Proc. 2nd IEEE WMCSA*, New Orleans, LA, Feb. 1999, pp. 90–100.
- [11] R. Leung, J. Liu, E. Poon, A.-L. C. Chan, and B. Li, "MP-DSR: A QoS-aware multi-path dynamic source routing protocol for wireless ad-hoc networks," in *Proc. 26th Ann. IEEE LCN*, Tampa, FL, Nov. 2001, pp. 132–141.
- [12] H. Markowitz, "Portfolio selection," *J. Finance*, vol. 7, no. 1, pp. 77–92, Mar. 1952.
- [13] S. Boyd and L. Vandenberghe, *Convex Optimization*. Cambridge, U.K.: Cambridge Univ. Press, 2004.
- [14] D. P. Palomar and M. Chiang, "A tutorial on decomposition methods for network utility maximization," *IEEE J. Sel. Areas Commun.*, vol. 24, no. 8, pp. 1439–1451, Aug. 2006.
- [15] M. Evans, N. Hastings, and B. Peacock, *Statistical Distributions*, 3rd ed. New York: Wiley, 2000.
- [16] S. W. Roberts, "Control chart tests based on geometric moving averages," *Technometrics*, vol. 42, no. 1, pp. 97–101, Feb. 2000.
- [17] V. Paxson and M. Allman, "Computing TCP's retransmission timer," RFC 2988, Nov. 2000 [Online]. Available: <http://www.ietf.org/rfc/rfc2988.txt>
- [18] I. R. James, "Products of independent beta variables with applications to Connor and Mosimann's generalized dirichlet distribution," *J. Amer. Stat. Assoc.*, vol. 67, no. 340, pp. 910–912, Dec. 1972.
- [19] W. F. Sharpe, *Investors and Markets: Portfolio Choices, Asset Prices, and Investment Advice*. Princeton, NJ: Princeton Univ. Press, 2007.