

Design and implementation of Smart Greenhouse using IOT

BhupeshDeka¹, Satyabrata Dash², Sitanath biswas³

^{1,3}Associate Professor, Department of Computer Science Engineering, Gandhi Institute For Technology (GIFT), Bhubaneswar

²Assistant Professor, Department of Computer Science Engineering, Gandhi Engineering College, Bhubaneswar

ABSTRACT— Greenhouse Automation System is the technical approach in which the farmers in the rural areas will be benefitted by automatic monitoring and control of greenhouse environment. It replaces the direct supervision of the human. In this paper the different papers have been reviewed and developed the proposed system based on the limitation in the present monitoring system. It also focuses on the Generic Architecture which can be applied for many other Automation Application. Greenhouse is a building where plants are grown in a controlled manner. Nowadays due to urbanization and lack of land availability there is a great need to construct the Greenhouses which will be reserved mainly for growing crops. With the advancement of technology we can control and monitor the multiple Greenhouses using IOT from the central location wirelessly.

Keywords— Arduino ATmega328, Atmospheric sensors, DC motor controlled sprinkler system.IOT.

I. INTRODUCTION

In this paper, the Design had been aimed data acquisition in greenhouse for multiple sensors to use data for simulation or processing to achieve the better enhancement of growth in greenhouse, this data has effect on the climate of greenhouse. Graphical User Interfaces (GUI) had been used through LabVIEW, firmware of arduino as software and arduino board and sensors as hardware. by using arduino mega board provides multiple inputs analogs and I/O digitals to made read data sensor easy to take temperature, humidity, CO₂ gas, also measuring the soil moisture that needed for irrigation plants and the intensity of lights that applied for greenhouse . These factors has the major effect on increase in growth of plants. Greenhouse environments monitoring different changes to parameters, the system for this purpose had been provided and given ability to control on climate of greenhouse.

The crop agriculture in greenhouse is higher affected by the surrounding conditions. The significant environmental factors for the quality and better productivity of the plants growth are temperature, relative humidity, Lighting, moisture soil, and the CO₂ amount in greenhouse. Continuous monitoring of these factors gives relevant information pertaining to the individual effects of the various factors towards obtaining maximum crop production [J. H. Shin et al., 1998]. Arduino is an open-source electronics prototyping platform based on flexible, easy-to-use hardware and software. It's intended for artists, designers, hobbyists, and anyone interested in creating interactive objects or environments. [David et al., 2007]. Arduino can sense the surroundings by

receiving input signal from a variety of sensors and can affect its environment via controlling heater, Water pump, and other actuators. The AVR Atmega2560 on the board is programmed using the Arduino programming language (depended on Wiring) and the Arduino development environment (depended on processing). Arduino projects can be stand-alone or they can communicate with software running on a computer (e.g. Flash, Processing, MaxMSP) A greenhouse is seen as a multivariable process presents a nonlinear nature and is influenced by biological processes [Herrero et al., 2007]. The five most important parameters must be taken into consideration when design a greenhouse are temperature, relative humidity, ground water, illumination intensity and CO₂ concentration. This parameters is important to realize that the five parameters mentioned above are nonlinear and extremely interdependent [Fourati et al., 2007; Blasco et al., 2007; Putter and J. Gouws, 1996]. the computer control system for the greenhouse involves the series steps [Melrolho, 1999]:

1. Acquisition of data through sensors.
2. Processing of data, comparing it with desired states and finally deciding what must be done to change the state of system.
3. Actuation component carrying the necessary action.

This paper describes a solution to the first part of the system. The information is obtained from multi-sensors station and is transmitted through USB port to computer.

II. RELATED WORK

This project describes the design of a greenhouse monitoring & controlling system based on IOT using Arduino. Some of the previous systems used android phone to monitor the green house but lacked to control it using android from remote locations. One of them was based on Global System for Mobile Communications (GSM) in which notifications are sent via SMS, but disadvantage of this system was everytime user had to type commands which was time consuming and costly. The biggest disadvantage of these systems was that one person always had to be present in the green house or in the vicinity of the green house[6]. The first problem which is overcome in our system is that a person need not always be present in the greenhouse. Plants in green house are grown under controlled environment. The temperature differences can cause harm to plants. Sometimes the farmers cannot predict which action needs to be taken so to control the environment and may take wrong decisions thus causing more harm to the plants in the green house. Our system will allow him to take proper decisions by providing the status of the sensors to the farmer with accurate information through the IOT web server. Thus this system helps farmer to control green house from remote locations.

III. THEORY

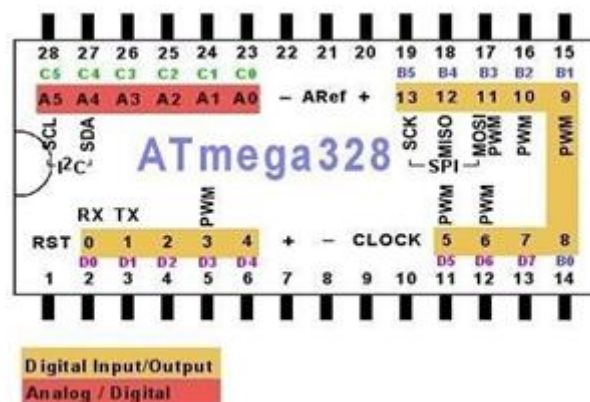

Fig:1: Pinout of ATmega 328

The Arduino are programmed using a dialect of feature from programming language C and C++. In addition to using traditional compiler tool chains, the Arduino provide integrated development environment (IDE) based on

A. Arduino UNO

The arduino Uno is a microcontroller board based on the ATmega328, It has 14 digital input/output pins, 6 analog input, a 16 MHZ crystal oscillator, a USB connection, a power jack, an ICSP header, and a reset button. The Uno differ from all preceding boards in that it does not use the FTDI USB to serial driver chip. "UNO" means one in Italian and is named to mark the upcoming release of arduino 1.0. The Uno is the latest in a series of USB Arduino boards and reference model for Arduino platform. The Arduino Uno can power via the USB connection or with external power supply. External power can come either from an AC to DC adapter or battery. The board can operate on an external supply of 6 to 20 volts. If supply with less than 7v, however, the 5v pin may supply less than five volts and the board may be unstable. The Tmega328 has 32 KB of flash memory for storing code .It has also 2KB of SRAM and 1KB of EEPROM. The Arduino software includes a serial monitor which allows simple textual data to be send to and from the Arduino board, The RX and TX LEDs on the board will flash when data is being transmitted via the USB to serial chip and USB connection to the computer.

A Software Serial library allows for serial communication on any of the UNO's digital pins, the arduino software includes a wire library to simplify use of the I2C bus. Arduino is open source hardware and software, which are license under the GNU lesser General public license, which is permitting the manufacture of Arduino board and software distribution by anyone.

processing language project[1].

B. Atmospheric Sensor's

i) Soil Moisture Sensor:

The two copper leads act as the sensor probes.

They are immersed into the specimen soil whose moisture content is under test. The conductivity of soil depends upon the amount of moisture present in it. It increases with increase in the water content of

the soil that forms a conductive path between two sensor probes leading to a close path to allow current flowing through.



Fig 2: Soil Moisture Sensor

ii) Light Sensor(LDR):

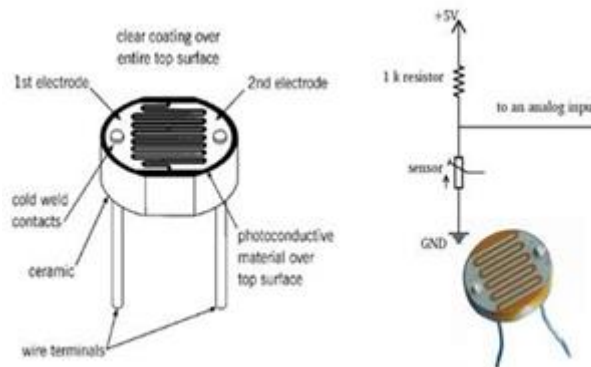

Fig 3: LDR Sensor

The light sensor is extremely sensitive in visible light range. With the light sensor attached to the system when the surrounding natural lights are low, it displays the digital values.

iii) Humidity Sensor(DHT11)

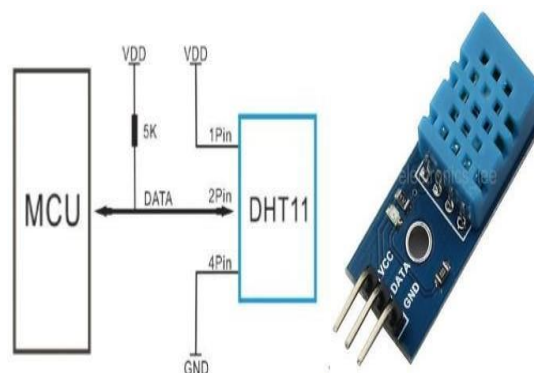

Fig 4: DHT11 Sensor

Humidity sensor is used for sensing the vapours in the air. The change in RH (Relative Humidity) of the surroundings would result in display of values.

The basic block diagram of green house system is as shown in fig .5. An Arduino platform micro- controller is used to obtain values of physical data through sensors connected to it. And then sensor's collected data is given to GPRS module.

- An arduino based Greenhouse Automation is designed.
- The arduino can be programmed with arduino software (IDE).
- Internet Of Things concept is used for showing the sensed data on web portalpage.

A. Mechanism

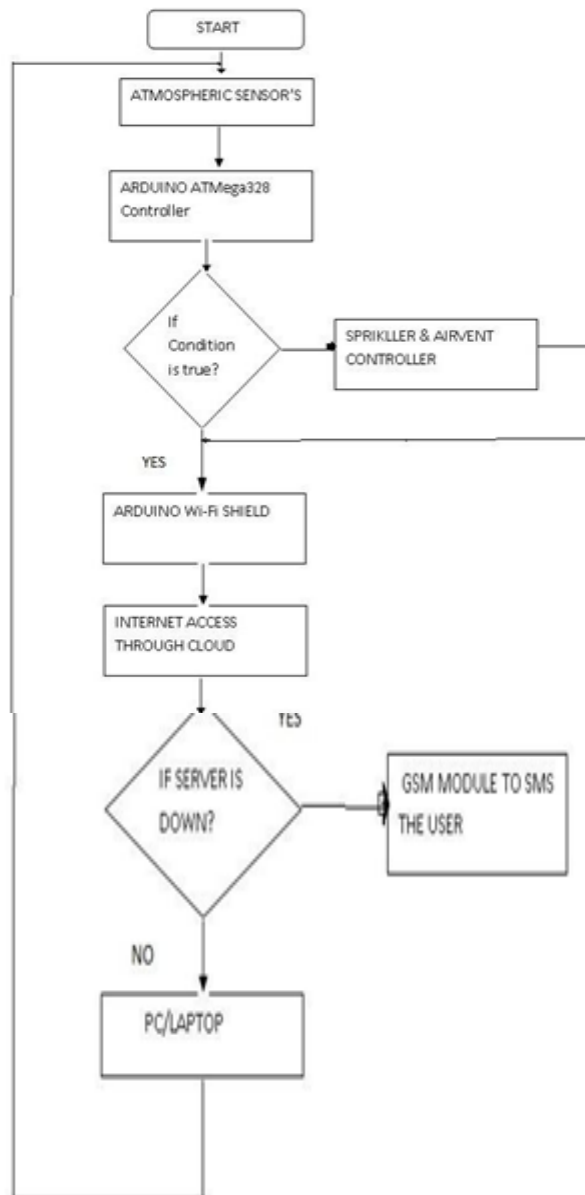

Fig 7: Flow chart

B. SoftwareImplementation

The software part programming through Arduino Uno software (IDE). It is easy to write code and upload it to the board.C and C++ language are used for programming.

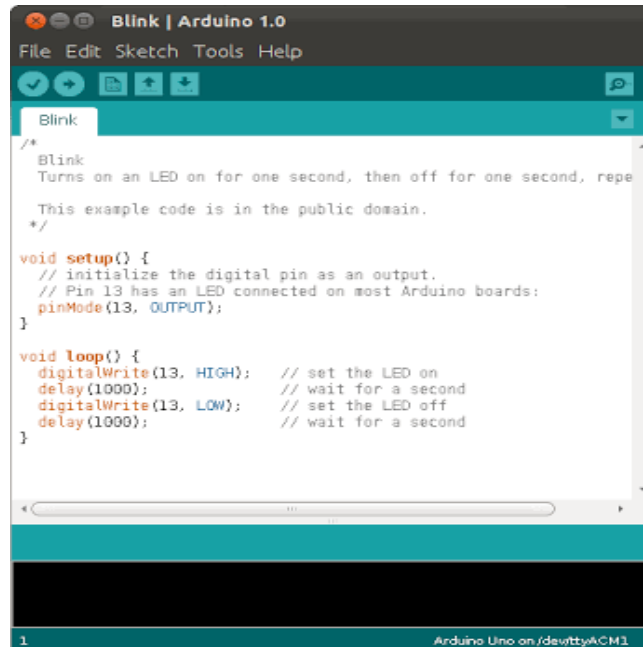

Fig 8: IDE Software

VI. EXPERIMENTAL RESULTS

In this proposed system we have used atmospheric sensor's, which is LDR light sensor, LM35 temperature, DHT11 humidity sensor. For these sensor's we have denoted some specific conditions or the threshold values .As per their climate the value will be change and the controlling action will

be taken by relays which is connected to the output side. And the changed data of atmospheric sensor's we can observed for analyzing on the screen of serial monitoring using the arduino uno kit and their IDE software. The hardware of proposed system and status of the sensor's shown in fig.9 & fig.10.

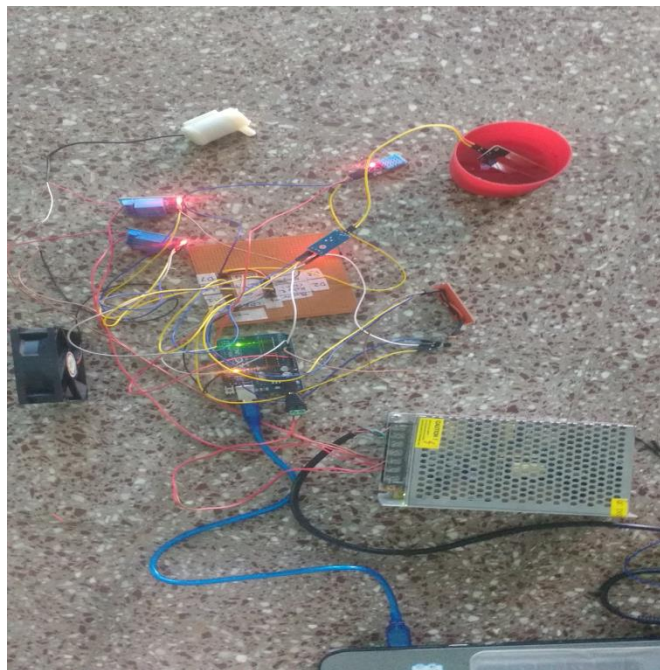

Fig 9: Hardware assembly

Technologies (ICIET'2014) Dec. 28-29, 2014
Bangkok (Thailand)

[6] Smart Green House Automation -Rahul
Belsare et al. / International Journal of
Computer Science & Engineering Technology

(IJCSET)

[7] www.arduino.cc

[8] http://www.adafruit.com/products/1438

[9] www.sparkfun.com

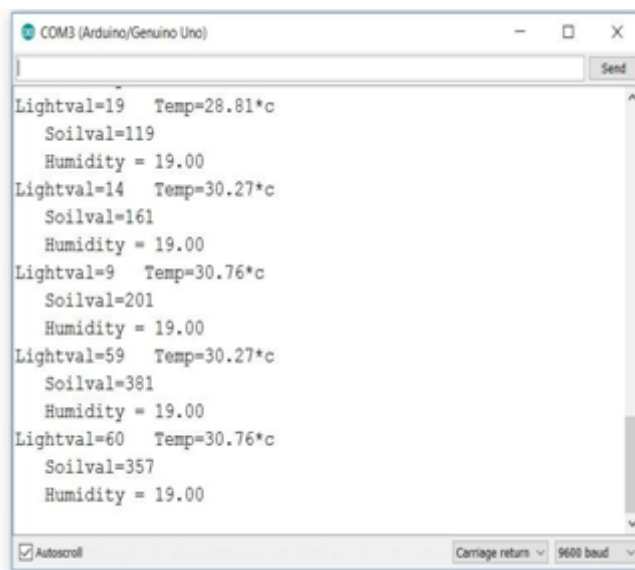

The screenshot shows a serial monitoring window titled 'COM3 (Arduino/Genuino Uno)'. The window contains the following text output:

```
Lightval=19 Temp=28.81*c  
Soilval=119  
Humidity = 19.00  
Lightval=14 Temp=30.27*c  
Soilval=161  
Humidity = 19.00  
Lightval=9 Temp=30.76*c  
Soilval=201  
Humidity = 19.00  
Lightval=59 Temp=30.27*c  
Soilval=381  
Humidity = 19.00  
Lightval=60 Temp=30.76*c  
Soilval=357  
Humidity = 19.00
```

At the bottom of the window, there are checkboxes for 'Autoscroll' (checked) and 'Carriage return' (unchecked), and a dropdown menu for '9600 baud'.

Fig 10: Serial Monitoring Output of Atmospheric Sensor's

- Arduino Uno ATmega328kit.
- AtmosphericSensor.

A. Advantages

- Totalautomationofgreenhouses/nurseries/biotech parks.
- Can be useddomestically.
- Easy to use, install, operate &troubleshoot.
- Useful for small scale farmers &green house owners.Low costsetup.

VII. CONCLUSION

Here, proposed design is implemented with Arduino platform for greenhouse monitoring , controlling temperature and soil moisture with the help of Web server usingIOT.

REFERENCES

- [1]. Data Acquisition Of Greenhouse Using Arduino - Journal Of Babylon University/ Pure And Applied Sciences/ No.(7)/ Vol.(22):2014
- [2]. Greenhouse Automation System Using Pso3 - Journal Of Information, Knowledge And Research In Electronics And Communication Engineering
- [3]. Arduino Based Automatic Plant Watering System - Devika Et Al., International Journal Of Advanced Research In Computer Science And Software Engineering 4(10),October - 2014, Pp.449-456,
- [4]. Volume 4, Issue 10, October 2014, ISSN:

- [5]. Remote Sensing In Greenhouse Monitoring System - SSRG International Journal Of Electronics And Communication Engineering (SSRG-IJECE) – EFES April2015
- [6]. Sensor Based Automated Shading Of Green House - International Conference On Innovative Engineering