

A Dynamic Model Of Synchronous Machine

Biya Motto Frederic^{1k}, Tchuidjan Roger², Ndzana Benoît²

Faculty of Science, University of Yaounde I, P.O.Box 812 Yaoundé, Cameroon;

National Advanced School of Engineering of Yaounde;

Corresponding author: Biya Motto Frederic

ABSTRACT

Synchronous electrical machines usually have three phase variable current winding in stator, direct current excitation winding in rotor and short closed loop distributed damping winding in rotor. The power of synchronous machines varies from kilowatts to megawatt. The main application of synchronous machines is found as generators of sinusoidal voltages in three phase systems. As motors, they are rarely used.

In this paper, we study the construction, the parameters, the equations and action principle of synchronous electrical machines.

Keywords: Dynamic model, synchronous machine

Date Of Submission:02-10-2018

Date Of Acceptance: 13-10-2018

I. INTRODUCTION

Since the un-transposed lines, unbalanced load and lines with different phases,

Active distribution network (ADN) always operates in three-phase imbalanced states. Consequently three-phase load flow should be used for electromagnetic transient (EMT) initialisation. To improve the accuracy of the initialisation of EMP model, harmonic load flow can be adopted [1 – 3]. Newton-Raphson and fixed-point-iteration method are both applicable for ADN load flow [4,5]. The main aim of this paper is to develop an elaborated unbalanced synchronous machine (SM) model and embedded in a three-phase load flow for EMT initialisation.

Sequence-component model of SM is widely used in ADN three-phase load flow approach [6 – 8]. The sequence-decoupled model can simply unbalanced load flow approach [9], while it cannot cope with constraints for three-phase active power summation.

In [10], phase domain SM model is presented and solved via Newton-Raphson for unbalanced load flow analysis. Sequence component model of SM is studied in [11], while both [10,11] use sequence component parameters for SM and is not suitable for EMT software, such as MATLAB/SimPowerSystems, PSCAD/EMTP etc. in which d- and q-axis-based SM parameters are used. Meanwhile the damping windings in d- and q-axis are not fully considered in [10,11], which has an impact on the accuracy of unbalanced load flow. Lipo proposed an unbalanced harmonic analysis model of synchronous machine with the extension of the d-q theory [12], while it is a linear

harmonic model and cannot account for unbalanced load flow. Meanwhile, saturation phenomenon has a great impact on the modelling of SM which is not considered in [12].

In this paper, we present a new dynamic model of synchronous machine.

II. CONSTRUCTION OF SYNCHRONOUS MACHINE AND WINDING PARAMETERS

A synchronous electrical machine has a cylindrical construction. The representation is shown on figure 1.

The machine is composed of stator and rotor. The rotor is introduced on the shaft.

The rotor magneto conductor can be salient or non-salient. Salient rotors are used in machines with four or more poles. The number of rotor poles as a rule is the number of stator poles.

The salient rotor magneto conductor has two symmetry axes: the longitudinal **d** and the transversal **q**. The synchronous machine magnetic system is characterized by the diagonal matrix of magnetic conductances:

$$\Lambda_{dq} = \text{diag}(\lambda_d, \lambda_q)$$

Where λ_d and λ_q are magnetic conductances on axes d and q respectively.

The poles can be permanent magnets or can have electromagnetic excitation that should have excitation winding.

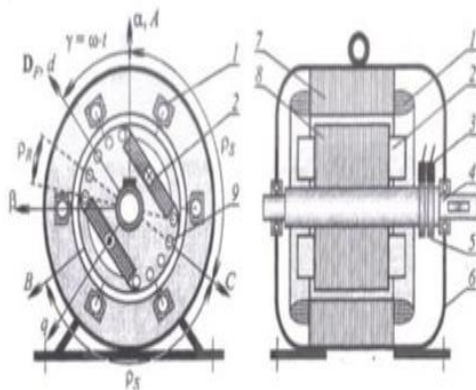

Figure 1: Schematic representation of three phase synchronous machine with salient rotor:

- 1- Stator winding ; 2- rotor excitation winding ;
- 3- brush ; 4- shaft ; 5- Slip ring ; 6- end shield ;
- 7- Stator magneto conductor ; 8- rotor magneto conductor ; 9- rotor damping winding.

The excitation winding F of the synchronous machine is enrolled on rotor poles. On the excitation winding we send permanent voltage through the rings with brushes.

The excitation winding F creates magnetic flux that acts along the longitudinal axis of magnetic symmetry d .

The magnetic axis of excitation winding F corresponds with magnetic symmetry axis d and is characterized by the vector $D_F^T = [1, 0]$.

The excitation winding has active resistance R_F , inductance of dispersion L_F and main inductance $L_{FF} = W_F \cdot D_F^T \Delta_{dq} \cdot D_F \cdot W_F$,

Where W_F – number of turns of excitation winding

DAMPING WINDING R is not a compulsory element on synchronous machine rotor construction, but it is present in most of the synchronous electromotors.

If damping winding conductors are closed along the rotor circle, the winding is said to be total. If conductors are closed only on a pole sector, the winding is said to be longitudinal. The damping winding permits to calm the rotor oscillations that occur with load variations. They are also used as starting winding when the synchronous machine works in asynchronous regime.

The total two-poles damping winding (figure 2) composed of $2 \cdot n$ ($n \geq 4$) active conductors in poles slots and two ring formed joints.

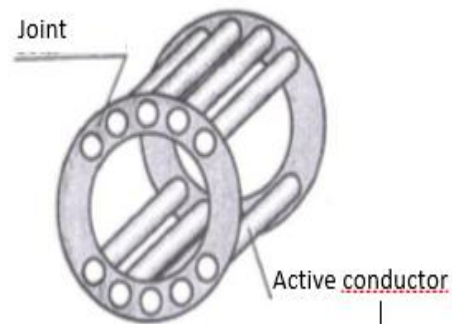

Figure 1: Total Shortclosedloop damping rotor winding

We note r_2/n the resistances of $2n$ damping winding active conductors. The resistances of joint short parts are noted r_s while the resistances of long parts are noted r_l . The number of joint short parts is equal to $2 \cdot (n-1)$, the number of long parts is -2 . The joint parts resistances are linked in $2 \cdot n$ - phase polyangle and they have total resistance.

$$r_T = 2 \cdot [(n - 1) \cdot r_s + r_l]$$

If we transform joint $2 \cdot n$ - phase polyangle resistances to equivalent $2 \cdot n$ star phase, then we construct n closed loops with diametral active parts. The first and n^{th} loops will have resistance.

$r_0 = r_2 + 4 \cdot r_s \cdot r_l / r_T$, and the rest $(n-2)$ loops – resistance $r_1 = r_2 + 4 \cdot r_s^2 / r_T$

The resistances of loops are represented by diagonal matrix:

$$R_R = \text{diag}(r_0, r_1, \dots, r_1, r_0)$$

If the faces link of active conductors is made of uniform material, then

$$r_0 = r_2 \cdot (1 + K_0); \quad r_1 = r_2 \cdot (1 + K_1),$$

$$\text{Where } \begin{cases} K_0 = d_T \cdot \alpha_p^* \cdot [1 - \alpha_p^* \cdot (n - 1)] / n, \\ K_1 = d_T \cdot \frac{\alpha_p^*}{n^2} \end{cases}$$

They are coefficients taking into account the increase of active conductors' resistances r_2 because of resistance of long and short parts of joint in active conductors respectively; $d_T = r_T / r_2$. Dispersion inductances of loops are defined in analogous manner with active resistances and can be expressed by diagonal matrix

$$L_R = \text{diag}(l_0, l_1, \dots, l_1, l_0),$$

Where $l_0 = l_2 \cdot (1 + K_0); \quad l_1 = l_2 \cdot (1 + K_1)$; l_2 – dispersion inductances of active conductors.

K_0, K_1 are coefficients taking into account the increase of l_2 due to long and short parts of joint of active conductors respectively.

Damping winding loops form n - phase winding. The space orientation of magnetic axis of n -phase symmetric non salient rotor damping winding is characterized by phase matrix:

$$D_R = \begin{bmatrix} \cos(\alpha_1) \cos(\alpha_1 + \rho_R) \dots \dots \dots \cos(\alpha_1 + (n-1) \cdot \rho_R) \\ \sin(\alpha_1) \sin(\alpha_1 + \rho_R) \dots \dots \dots \sin(\alpha_1 + (n-1) \cdot \rho_R) \end{bmatrix}$$

Where $\alpha_1 = [\rho_R \cdot (1 - n) - \pi]/2$ – deviation angle of magnetic axis of winding first phase R relatively to axis of magnetic symmetry d;
 ρ_R – deviation angle of magnetic axes of winding R relatively.

The matrix of main inductance of damping winding

$$L_{RR} = W_R \cdot D_R^T \cdot \Lambda_{dq} \cdot D_R \cdot W_R$$

Non salient Rotor is used generally in high speed machines with pair of poles not greater than two. Magneto conductor of non-salient rotor is symmetric ($\lambda_d = \lambda_q$). The schematic representation of non-salient rotor of synchronous machine with two poles is shown on figure 3. There is not damping winding.

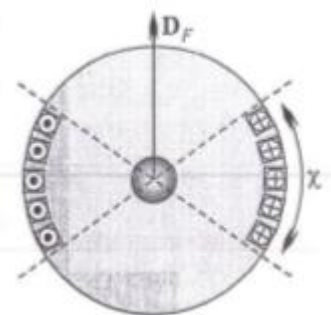

Figure 2: Non-Salient rotor

Magneto conductor of stator is a complete cylinder. It has slots. We often enrol winding composed of m-phase windings (three A, B, C). Phase windings are often linked in star.

The stator winding is characterized by diagonal matrices of resistances and dispersion inductances.

$$R_S = R_S \cdot 1 ; L_S = L_S \cdot 1$$

Magnetic axes of stator phase windings are each other deviated relatively by angle.

$\rho_S = 2\pi/m$, Where m – number of phases.

Phase matrix of stator windings can be expressed as follows:

$$D_S = \begin{bmatrix} 1 & \cos(\rho_S) \cos(2\rho_S) \dots \cos(m-1) \cdot \rho_S \\ 0 & \sin(\rho_S) \sin(2\rho_S) \dots \sin(m-1) \cdot \rho_S \end{bmatrix}$$

Static coordinate axes α, β are linked with rotating coordinates of magnetic symmetry d,q by rotation matrix:

$$\nabla(\gamma) = \begin{bmatrix} \cos(\gamma) & -\sin(\gamma) \\ \sin(\gamma) & \cos(\gamma) \end{bmatrix}$$

Where $\gamma = \omega t$ – rotating angle;

ω – rotating speed of rotor.

Phase matrix of stator windings in rotor rotation coordinates **d,q**

$$D_S \rightarrow R = \nabla(\gamma)^T \cdot D_S$$

Main inductances of stator three phase windings in rotor rotating coordinates **d,q** can be characterized

$$L_{SS}(\gamma) = W_S D_S^T \Lambda_{dq} D_S W_S = W_S D_S^T \nabla(\gamma) \cdot \Lambda_{dq} \cdot \nabla(\gamma)^T \cdot D_S \cdot W_S$$

Where W_S – stator phase winding number of turns.

The main inductances of stator and rotor windings are matrices whose aspect is similar to generalized machine:

$$\begin{bmatrix} L_{SS}(\gamma) L_{SR}(\gamma) L_{SF}(\gamma) \\ L_{RS}(\gamma) L_{RR} L_{RF} \\ L_{FS}(\gamma) L_{FR} L_{FF} \end{bmatrix}$$

Where

$$\begin{aligned} L_{SR}(\gamma) &= L_{RS}^T(\gamma) = W_S \cdot D_S^T \nabla(\gamma) \cdot \Lambda_{dq} \cdot D_R \cdot W_R; \\ L_{SF}(\gamma) &= L_{FS}^T(\gamma) = W_S \cdot D_S^T \nabla(\gamma) \cdot \Lambda_{dq} \cdot D_F \cdot W_F; \\ L_{RF} &= L_{FR}^T = W_R \cdot D_R^T \cdot \Lambda_{dq} \cdot D_F \cdot W_F. \end{aligned}$$

III. EQUATIONS OF SYNCHRONOUS ELECTRICAL MACHINE CHARACTERIZING THE DYNAMICS OF ELECTROMAGNETIC PROCESSES

Equations that characterize the dynamics of electromagnetic processes in a synchronous machine are expressed from the Kirchhoff's laws for stator windings S, damping rotor winding R and excitation winding F.

$$U_S = R_S \cdot I_S + L_S \cdot P I_S + P \{ L_{SS}(\gamma) \cdot I_S + L_{SR}(\gamma) \cdot I_R + L_{SF}(\gamma) \cdot i_F \};$$

$$U_R = R_R \cdot I_R + L_R P I_R + P \{ L_{RS} \cdot I_S + L_{RR} \cdot I_R + L_{RF} \cdot i_F \} \quad (1)$$

$$U_F = R_F \cdot i_F + L_F \cdot P i_F + P \{ L_{FS}(\gamma) I_S + L_{FR} \cdot I_R + L_{FF} \cdot i_F \}$$

These equations have periodical coefficients and they are called ‘equations in real coordinate system’

If we accomplish the change of variables considering

$$I_1 = \frac{2}{m} \cdot \nabla(\gamma)^T \cdot D_S \cdot I_S; I_2 = \frac{W_R}{W_S} \cdot \frac{2}{m} \cdot D_R \cdot I_R; I_f = \frac{W_F}{W_S} \cdot \frac{2}{m} \cdot D_F \cdot I_f$$

$$U_1 = \frac{2}{m} \cdot \nabla(\gamma)^T \cdot D_S \cdot U_S; U_2 = 0; U_f = \frac{W_S}{W_F} \cdot D_F \cdot U_F;$$

Then equations (1) will look like:

$$U_1 = R_1 \cdot I_1 + L_1 P I_1 + \omega \cdot E \cdot L_1 \cdot I_1 + L_0 P I_0 + \omega \cdot E L_0 \cdot I_0;$$

$$0 = R_2 \cdot I_2 + L_2 P I_2 + L_0 P I_0;$$

(2)

$$U_f = R_f \cdot I_f + L_f \cdot P I_f + L_0 \cdot P \cdot I_0$$

Where $I_0 = I_1 + I_2 + I_f$; $L_0 = \text{diag}(L_{dd}, L_{qq}) = \frac{m}{2} \cdot W_S^2 \cdot A_{dq}$;

$$E = \nabla(\pi/2); R_1 = R_S; L_1 = L_S;$$

$$R_2 = \text{diag}(R_{2d}, R_{2q}) = \frac{m}{2} \cdot W_S^2 \cdot (D_R \cdot D_R^T)^{-2} \cdot D_R \cdot R_R \cdot D_R^T;$$

$$L_2 = \text{diag}(L_{2d}, L_{2q}) = \frac{m}{2} \cdot W_S^2 \cdot (D_R \cdot D_R^T)^{-2} \cdot D_R \cdot L_R \cdot D_R^T$$

$$L_f = m/2 \cdot (W_S/W_F)^2 \cdot L_F; R_f = m/2 \cdot (W_S/W_F)^2 \cdot R_F.$$

The products of matrices $D_R \cdot R_R \cdot D_R^T$ and $D_R \cdot L_R \cdot D_R^T$ can be expressed as follows:

$$D_R \cdot R_R \cdot D_R^T = r_1 \cdot K_R(n-2, \rho_R) + r_0 \cdot K_R(2, \rho_R \cdot (n-1));$$

$$D_R \cdot L_R \cdot D_R^T = l_1 \cdot K_R(n-2, \rho_R) + l_0 \cdot K_R(2, \rho_R \cdot (n-1));$$

Where :

$$K_R(n, \rho_R) = D_R \cdot D_R^T = \frac{n}{2} \cdot \text{diag} \left(1 - \frac{\sin(n \cdot \rho_R)}{2 \cdot \sin(n \cdot \rho_R)}, 1 + \frac{\sin(n \cdot \rho_R)}{2 \sin(n \cdot \rho_R)} \right)$$

Current vectors I_1, I_2, I_f and voltage vectors U_1, U_f have dimension 2 and are characterized by two coordinates in plane.

$$I_1 = \begin{bmatrix} i_{1d} \\ i_{1q} \end{bmatrix}; I_2 = \begin{bmatrix} i_{2d} \\ i_{2q} \end{bmatrix}; I_f = \begin{bmatrix} i_f \\ 0 \end{bmatrix}; U_1 = \begin{bmatrix} U_{1d} \\ U_{1q} \end{bmatrix}; U_f = \begin{bmatrix} U_f \\ 0 \end{bmatrix}$$

Equations (2) are written in coordinates axes of rotor magnetic symmetry d,q. In the developed form:

$$u_{1d} = R_1 \cdot i_{1d} + L_d \cdot P i_{1d} + L_{dd} \cdot P \{i_{2d} + i_f\} - \omega \cdot L_q \cdot i_{1q} - \omega \cdot L_{qq} \cdot i_{2q};$$

$$u_{1q} = R_1 \cdot i_{1q} + L_q \cdot P \cdot i_{1q} + L_{qq} \cdot P i_{2q} + \omega \cdot L_d \cdot i_{1d} + \omega \cdot L_{dd} \cdot \{i_{2d} + i_f\};$$

$$0 = R_{2d} \cdot i_{2d} + L_{2d} \cdot P i_{2d} + L_{dd} \cdot P \{i_{1d} + i_{2d} + i_f\};$$

$$(3) \quad 0 = R_{2q} \cdot i_{2q} + L_{2q} \cdot P i_{2q} + L_{qq} \cdot P \{i_{1q} + i_{2q}\};$$

$$u_f = R_f \cdot i_f + L_f \cdot P i_f + L_{dd} \cdot P \{i_{1d} + i_{2d} + i_f\};$$

Where $L_d = L_1 + L_{dd}$; $L_q = L_1 + L_{qq}$.

Electromagnetic torque on pair of poles in the coordinate system d,q is :

$$M = \frac{m}{2} \cdot (L_m \cdot I_1^T \cdot E_0 \cdot I_1 + I_1^T \cdot E \cdot L_0 \cdot I_2 + I_1^T \cdot E \cdot L_0 \cdot I_f); \quad (4)$$

Where $L_m = \frac{L_{dd} - L_{qq}}{2}$; $E_0 = \begin{bmatrix} 0 & 1 \\ 1 & 0 \end{bmatrix}$

Electromagnetic torque in developed form:

$$M = \frac{m}{2} \cdot (2b_m \cdot i_{1d} \cdot i_{1q} + L_{dd} \cdot i_{1q} \cdot i_f + L_{dd} \cdot i_q \cdot i_{2d} - L_{qq} \cdot i_{1d} \cdot i_{2q}) \quad (5)$$

The advantage of equations in coordinates d,q is the absence not only of periodicity on coefficients, but

also periodicity on external signals U_1, U_f and state variables I_1, I_2, I_f .

The equations system (3) can be represented by one matrix equation:

$$L \cdot P I = -A I + U \quad (6)$$

Where $U^T = [U_{1d} U_{1q} \quad 0 \quad 0 \quad U_f]$; $I^T = [i_{1d} i_{1q} i_{2d} i_{2q} i_f]$;

$$L = \begin{bmatrix} L_1 + L_{dd} & 0 & L_{dd} & 0 & L_{dd} \\ 0 & L_1 + L_{qq} & 0 & L_{qq} & 0 \\ L_{dd} & 0 & L_{2d} + L_{dd} & 0 & L_{dd} \\ 0 & L_{qq} & 0 & L_{2q} + L_{qq} & 0 \\ L_{dd} & 0 & L_{dd} & 0 & L_f + L_{dd} \end{bmatrix}$$

$$A = \begin{bmatrix} R_1 - \omega L_q & 0 & -\omega L_{qq} & 0 \\ \omega L_d R_1 \omega L_{dd} & 0 & \omega \cdot L_{dd} \\ 0 & 0 & R_{2d} & 0 & 0 \\ 0 & 0 & 0 & R_{2q} & 0 \\ 0 & 0 & 0 & 0 & R_f \end{bmatrix}$$

If excitation winding has stabilisation system of current i_f , then for the dynamic processes analysis, we can assume that excitation winding is supplied from current source.

Therefore $P i_f = 0$. In that case the description can be done with only the four first equations in (3)

$$u_{1d} = R_1 \cdot i_{1d} + L_d \cdot P i_{1d} + L_{dd} \cdot P i_{2d} - \omega \cdot L_q \cdot i_{1q} - \omega \cdot L_{qq} \cdot i_{2q};$$

$$u_{1q} - \omega \cdot L_{dd} \cdot i_f = R_1 \cdot i_{1q} + L_q \cdot P i_{1q} + L_{qq} \cdot P i_{2q} + \omega \cdot L_d \cdot i_{1d} + \omega \cdot L_{dd} \cdot i_{2d}$$

$$0 = R_{2d} \cdot i_{2d} + (L_{2d} + L_{dd}) \cdot P i_{2d} + L_{dd} \cdot P i_{1d}; \quad (7)$$

$$0 = R_{2q} \cdot i_{2q} + (L_{2q} + L_{qq}) \cdot P i_{2q} + L_{qq} \cdot P i_{1q};$$

The equations system (7) can be represented by a single matrix equation:

$$L_N \cdot P I_N = -A_N \cdot I_N + U_N \quad (8)$$

Where :

$$L_N = \begin{bmatrix} L_d & 0 & L_{dd} & 0 \\ 0 & L_q & 0 & L_{qq} \\ L_{dd} & 0 & L_{2d} + L_{dd} & 0 \\ 0 & L_{qq} & 0 & L_{2q} + L_{qq} \end{bmatrix}; U_N = \begin{bmatrix} U_{1d} \\ U_{1q} \\ -\omega \cdot L_{dd} \\ 0 \\ 0 \end{bmatrix}$$

$$A_N = \begin{bmatrix} R_1 - \omega L_q & 0 & -\omega L_{qk} \\ \omega L_d R_1 \omega L_{dd} & 0 & 0 \\ 0 & 0 & R_{2d} & 0 \\ 0 & 0 & 0 & R_{2q} \end{bmatrix}; I_N = \begin{bmatrix} i_{1d} \\ i_{1q} \\ i_{2d} \\ i_{2q} \end{bmatrix}$$

IV. CONCLUSIONS

Synchronous electrical machines have m-phases winding alternative current in stator. The stator winding of non-salient machine is characterized by inductances whose expressions depend on rotor position. The rotor of synchronous machine has excitation winding and damping winding with inductances that do not depend on rotor position.

Damping winding of salient machine can be divided into two equivalent windings without any magnetic relationship. One of the windings has magnetic relationship with excitation winding while the other one does not. The matrix of mutual inductances of stator and rotor windings is a periodical function rotor rotation angle.

REFERENCES

- [1]. Xu W.W., Dommel H.W., Marti J.R.: 'A synchronous machine model for three-phase harmonic analysis and EMTP initialization', IEEE Trans. Power Syst., 1991, 6, (4), pp. 1530-1538
- [2]. Murere G., Lefebvre S., Do X.D.: 'A generalized harmonic balance method for EMTP initialization', IEEE Trans. Power Deliv., 1995, 10, (3), pp.1353-1359
- [3]. Lombard X., Mahseredjian J., Lefebvre S., ET AL.: 'Implementation of a new harmonic initialization method in the EMTP', IEEE Trans. Power Deliv., 1995, 10, (3), pp. 1343-1352
- [4]. Perkins B.K., Marti J.R., Dommel H.W.: 'Nonlinear elements in the EMTP: steady-state', IEEE Trans. Power Syst., 1995, 10, (2), pp.593-601
- [5]. Arrillaga J.: 'Power system harmonic analysis' (John Wiley & Sons, Hoboken, NJ, USA, 1997). doi:10.1002/9781118878316.ch6
- [6]. Chen T.H., Chen M.S., Inoue T., ET AL.: 'Three-phase cogenerator and transformer models for distribution system analysis', IEEE Trans. Power Deliv. 1991, 6, (4), pp.1671-1681
- [7]. Ju Y., Wu W., Zhang B., ET AL.: 'An extension of FBS three-phase power flow for handling PV nodes in active distribution networks', IEEE Trans. Smart Grid, 2014, 5, (4), pp.46-59
- [8]. Ju Y., Wu W., Zhang B., ET AL.: 'Three-phase steady-state models for distributed generators', Proc. CSEE, 2014, 34, (10) pp. 1509-1518
- [9]. Kamh M. Z.: 'Component modelling and three-phase power flow analysis for active distribution systems' (University of Toronto, Ontario, M5S 3G4, Canada, 2011)
- [10]. Wasley R.G., Shlash M.A.: 'Steady-state phase-variable model of the synchronous machine for use in 3-phase load-flow studies', Proc. Inst. Electr. Eng., 1974, 121, (10), pp.1155-1164
- [11]. Tamura T., Takeda I.: 'A synchronous machine model for unbalanced analyses', Electr. Eng. Jpn., 1997, 119, (2), pp.46-59
- [12]. Lipo T.A.: 'Analysis of synchronous machines' (Taylor & Francis Group, Boca Raton, Florida, USA, 2012, 2ndedn.)