

Fault Analysis of Inverter Based Distributed Generation in Different Operational Mode

Arnab Ghosh *

*(Department of Electrical Engineering, Institute of Engineering and Management, Kolkata, University of Engineering and Management, Kolkata)

ABSTRACT

Use of distributed generation (DG) is increasing rapidly. Concerns have been raised about the impacts of the improper operation of these on the protection systems. The limiting fault current ability for inverter based distributed generation (IBDG) can lead to the distribution network malfunctioning. With the presence of inverter based DG (IBDG), the fault current calculation by application of z bus matrix may be impractical due to difficulty in estimating the transient impedance of inverter based DG. To analyze system changes and dynamics in the system fault response with inverter-based DGs due to its non linearity, a simulation process has been developed to incorporate an inverter-based DG model. In this work, dual loop voltage with active power control is done. A three phase fault is applied to find fault current contribution in the network by IBDG in grid connected mode and island mode. It is found that for these two modes completely different protection systems are required.

Keywords–Fault Analysis, Inverter based DG; Island mode; Grid connected mode; Dual loop voltage controller

Date of Submission: 01-02-2024

Date of acceptance: 10-02-2024

I. INTRODUCTION

Implementation of small scale energy units like fuel cell, PV cell, hydro and wind energy have made systems more efficient than large units due to technical innovation. The main objectives of electric power industries these days are to secure future energy scenario and to reduce greenhouse gas (GHG) emissions. One of the main concerns of deregulated environment is to minimize the energy supply costs. To solve these problems distributed generation (DG) have become an attractive option. A DG connected distribution system is beneficial economically, environmentally and technically [1]. It improves voltage profile, reliability and is technically beneficial. Power electronic interfaces are employed for many renewable energy sources. They are connected through inverter to the electrical distribution network because either their output is not directly compatible to the grid (photovoltaic panels, micro turbines) or to extract maximum energy due to the flexibility of control of the associated power electronics (wind turbines with doubly fed induction generators (DFIG) or full inverter interfaces).

DG has negative impacts on voltage and frequency control, protection and voltage distortion problems [2, 3]. In case of downstream fault the DGs connected to the grid increases the short circuit current. In addition, DG participation in fault current contribution reduces the grid fault current. The risk of

blinding protection may therefore be increased. Moreover, direction of power flow and fault currents may be changed. Therefore, if faults occur on a neighbouring feeder, the relay can be inappropriately tripped due to DG contribution. This is known as “sympathetic tripping” [4]. In inverter, fault current is limited due to low thermal inertia of semi conductor switches. Sometimes fault current supplied by asynchronous machines is 100 to 400% of rated current [5]. It may be at 500-1000% for the first few cycles and then it decays up to 200-400% for synchronous machines [5]. In case of induction machines, fault current level increase up to 500-1000% during first few cycles and then decreases to an insignificant amount in 10 cycles [5]. Permanent tripping of relay or CB is not required in case of temporary faults occurring on a line [6]. During fault the re-closer is automatically disconnected and it is automatically reclosed after a short interval when arc extinguishing is completely done. This process occurs repeatedly after which the line is permanently disconnected even if the fault persists. However, with IBDG installed, the inverter continues to energize the fault by developing arc, which may transform the temporary fault to a permanent one [6].

DG is still considered to be an ideal source. In a recent work, the DG is modelled without taking the control system into consideration [7]. A voltage source inverter (VSI) is connected with DC source and Insulated Gate Bipolar Transistor (IGBT) is used

as switching device. It is found that fault current is only 2 times of rated current since it is limited by switching device [8]. Full control of both active and reactive power can be properly designed with acceptable total harmonic distortion in grid current [9]. In case of IBDG, power converters are used with switching frequencies in the range of 1–20 kHz causing harmonics injection to the network. Due to this harmonics, protection devices such as circuit breaker, relay may be triggered [10]. Harmonics can be mitigated by the use of an inductor-capacitor-inductor (LCL) filter between the grid and the power converter. LCL filter introduces higher attenuation with small sized passive elements. Thus IEEE 519-1992 standards are met with relatively low switching frequency converters [11]. An LCL filter provides better dynamics, when compared to a simple L- filter. Control design challenges are introduced by the third order nature of LCL filter due to hindrance related to filter resonance occurrence and corresponding stability constraints [12]. Thereby, the engaged control system affects the overall system behaviour throughout healthy and abnormal conditions.

A number of attempts for characterization of inverter faults have been studied previously. Many types of control technique are used to represent DG as a constant PQ source or PV source. The investigation on the effect of PQ controlled inverters on fault level is done by full time domain simulations where current limiting is done by instantaneous limits on the inductor current mentioned in this control system [13]. A study to analyse the fault response of inverter based distributed generators in stand-alone networks was carried out elsewhere [14]. Conventional fault analysis method of islanded microgrid can directly use this proposed fault model. The model is developed in PSCAD and time domain simulations are done for result analysis [14]. However all these models are more or less singular in their objectives. Therefore integration of different ideas of IBDG modelling will lead to a comprehensive model of DG fault analysis.

Output from renewable energy sources cannot be presumed easily. Thus to improve the system sustainability and performance, non renewable sources are necessary. For same network with constant load demand, DG may be operated in island mode or grid connected mode depending on energy source. On the other hand for protection purpose, fault analysis is important. In this work, short circuit current supplied by IBDG during three phase faults are investigated for island and grid connected mode with reduce penetration. Calculation of equivalent circuit is also not possible for IBDG. Hence, a complete simulation model of IBDG is made for fault analysis. An IEEE 14 bus network is

considered as distribution mesh for fault analysis purpose and a detailed modeling of IBDG with dual loop voltage control is done. A comparison is also made between grid connected mode and island mode of operation.

II. MODELLING OF INVERTER BASED DG

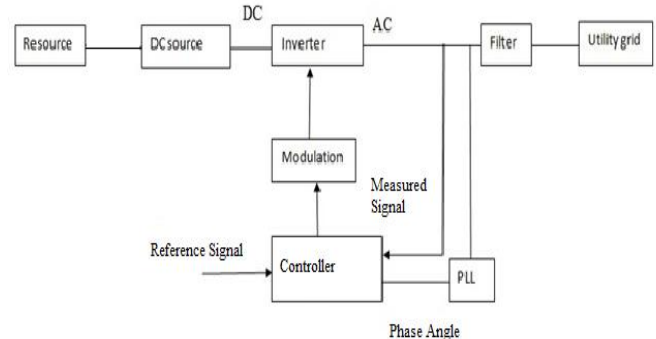

Fig. 1. Modelling of inverter based DG[15]

Fig. 1 shows the simplified diagram of the Inverter based DG model. DC voltage production takes place from some renewable energy sources. To reduce harmonics, inverter filter converts DC into AC. Phase lock loop (PLL) is utilized to mark the phase angle. The modulating signal is generated by comparing the reference and measure signal using proportional integral controller (PI) or proportional resonant (PR) controller. Different modulation techniques are utilized to generate triggering pulse for the thyristor bridge.

A. Island Mode

The proposed control for the parallel Voltage Source Inverter (VSI) system is based on the dual loop voltage control framework, which includes the voltage and current control loops [16]. The voltage reference v_{ref} is generated in 'dq' coordinate and amplitude will be controlled by the voltage control. Initially, the generated voltage in 'abc' coordinate is transformed to 'dq' coordinates by Park's Transformation. This is used for PI controller. For PR controller, 'abc' coordinate is transformed to 'αβ' by Clarke Transformation. Fig. 2 shows a schematic diagram of dual loop schemes with voltage and current control loop. A phase-locked loop (PLL) is a control system where input and output signal phase are related to each other. To detect the phase or angular position this technique is mostly used [17]. For three phase system, Synchronous Frame PLL (SF-PLL) is most commonly used.

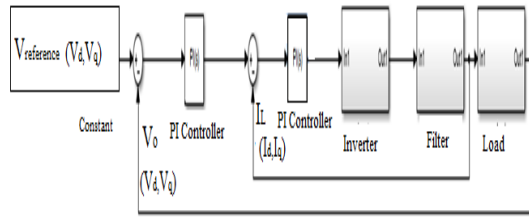

Fig. 2. Dual loop voltage regulator [18]

1) Voltage Controller

The direct control of amplitude and frequency in case of voltage regulated voltage source inverter based DG units is done by a linear voltage regulator placed either as a single-loop or a dual-loop feedback controller. An inner current control loop and an outer voltage control loop comprises the dual loop regulator which helps to improve the stability of a single-loop voltage controller. From Fig. 2, it is seen that first a reference voltage V_{ref} is compared with output voltage and an error signal is generated which is then passed through a controller block to generate a current reference. The reference current is next compared with the output current of the inverter, generating an error signal. This signal is passed through the PI/PR controller to generate a modulating signal which is converted into 'abc' reference frame and fed to the pulse width modulator (PWM). The whole system operation is presented in dq reference frame when PI controller is used and in $\alpha\beta$ reference frame for PR controller. To make the system stable, the inner current loop must be tuned faster than the outer voltage control loop [18]

2) LCL filter design

a) Design of the Converter Side Inductor L_1 :

The THD of converter-side inductor current is limited to 10% when L_1 is designed. L_1 can be calculated as follows in (1) as [19]

$$L_1 = \frac{1}{3\sqrt{2}} \frac{E^2}{100.P} \frac{f_0}{f_{sw}} \frac{1}{THD} \sqrt{\left(\frac{3}{2} - \frac{4\sqrt{3}}{\pi} + \frac{9m^2}{8}\right)} \quad (1)$$

Where THD = total harmonic distortion, f_{sw} = switching frequency of PWM, f_0 = fundamental frequency, E = the out put voltage, P = rated power, m = modulating index,

b) Design of the Total Capacitance C_1 :

The value of total filter capacitance C_1 is designed to restrain the reactive power to 2.5% of rated power. The value of C_1 can be designed as in(2)

$$C_1 = \frac{2.5\% P}{100\pi E^2} \quad (2)$$

c) Design of the Grid Side Inductor L_2 :

To design L_2 the first resonant frequency ω_1 is set to 0.3 times ω_{sw} (switching frequency of PWM) according to the requirement of control bandwidth, the value of L_2 can be designed as in(3)

$$L_2 = \frac{L_1}{L_1 C \omega^2 - 1} \quad (3)$$

3) Proportional Integral Controller (PI)

It is used extensively and simultaneously along with 'dq' control, but its employment in 'abc' frame is also possible [20]. The transfer function of PI controller is described as in(4) The possibility of distorting the line current caused by background harmonics is a disadvantage in PI controllers which is initiated along the feed forward path in case of grid voltage distortion. This distortion can successively trigger LC resonance especially when an LCL filter is used at the converter AC output for filtering switching current ripple [19].

$$PI = K_p + \frac{K_i}{s} \quad (4)$$

Where K_p and K_i are the proportional and integral constant respectively.

4) Proportional Resonant Controller (PR)

Control loops designed by PR controllers contain terms adjusted at the fundamental frequency, fifth, seventh, and eleventh harmonics. The transfer function of PR controller is described as in (5) where K_p is proportional constant and K_i and K_r are resonant constant. Current control loop as well as voltage control loop includes current harmonic tracking to supply nonlinear currents to nonlinear loads, since it is necessary to contain voltage harmonics created by this kind of loads [21]. This technique enables harmonics elimination. To get proper sinusoidal current tracking at grid frequency a controller with large gain makes the control loop design easier and improves the system performance. In this case $\alpha\beta$ to $\alpha\beta$ transformation takes place first and then compared with reference signal [20].

$$PR = k_p + \frac{k_i s}{s^2 + \omega^2} + \sum_{h=5,7,11} \frac{k_{ph} s}{s^2 + (h\omega)^2} \quad (5)$$

B. Grid Connected Mode

Mostly renewable based DGs are connected to the grid through inverter based DG. Amplitude control of inverter based DG is same as island mode where a phase control is required. Fig. 3 shows the grid synchronization operation with a phase controller. The phase controller provides a phase difference between output voltage of inverter and grid [22]. The value of the phase difference is δ and approximate power flow can be calculated from (6). The phase difference error δ_{error} signal generated is given as in (7).

$$P_{in} = \frac{V_{abc1} \cdot V_{abc2} \sin \delta}{X} \quad (6)$$

Where δ is the phase difference between output voltage of inverter V_{abc1} and input voltage to the grid V_{abc2} . X is reactance between inverter and grid.

$$\delta_{error} = P_{average} - P_{ref} \quad (7)$$

This generated error is passed through a low pass filter and then through the PI controller which is applied to minimize the error of specified power output. It is then added with phase of output voltage of the inverter. To attenuate the disturbance from measurement, the cut-off frequency of the low pass filter has to be set at the appropriate value. The value must be high enough to provide a good transient response of the phase controller. Here the cut of frequency is set at 100 Hz. Finally, phase difference controller is used 'dq' to 'abc' transformation to transform the modulating signal to the 'abc' reference frame.

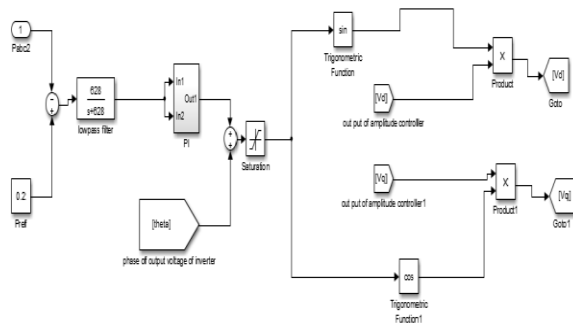

Fig. 3. Phase controller for grid synchronization and constant active power

III. SIMULATION SET UP

When DG is connected to the distributed network system, a mesh network system is formed, for which IEEE 14 bus system is considered. The single line diagram of an IEEE-14 bus system is shown in Fig. 4. Two generators are present in the system at bus no 1 and 2 and three synchronous condensers are present at bus 3, 6 and 8 respectively. The data is on 100 MVA base. The system data is taken from reference [23]. DG is connected by replacing the synchronous condenser of bus no 8. In Fig. 4 the highlighted area is considered for island mode of operation. It consists of 8 to 14 buses. DG is present in bus no 8. The inverter behaves as constant active reactive power source or constant voltage source with constant power. The inverter behavior is determined by the controls of that inverter and other electronic devices. So a complete model of inverter design is very important. For fault analysis of a grid connected

network, the model of inverter based DG is done under the speculation that the input voltage is driven by constant DC sources. The pulse width modulation (PWM) modulates the signal developed by a close loop feedback controlled inverter.

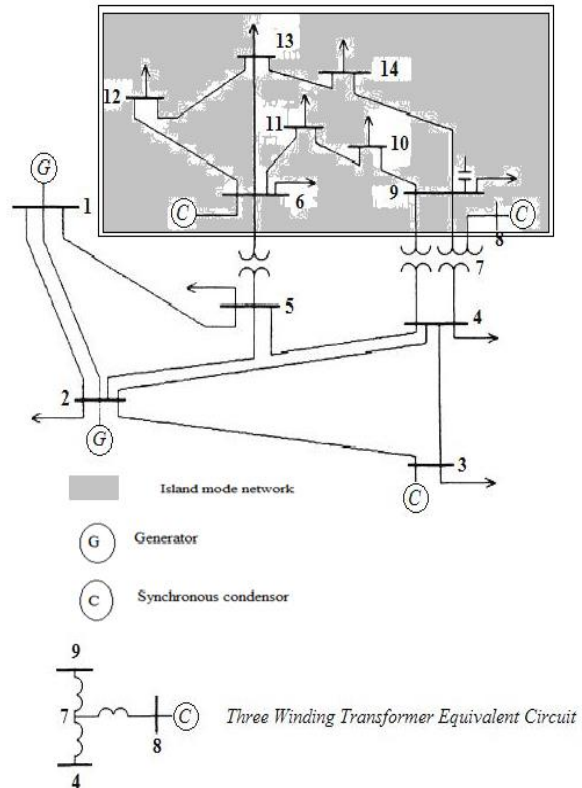

Fig. 4. One Line Diagram of IEEE-14 Bus System [22]

A. Island Mode Operation

The input inverter voltage is increased upto 10 p.u in order to supply the required power. DG output power is 0.8 P.U that is 80 MW considering base as 100MVA. All the specification of IBDG is given below in Table I. Parameters of PI or PR controller can be designed in both frequency domain and time domain. Controller gain tuning is one of the main important parts of this work. For linear system bode plot Ziegler Nichols methods is mainly used for controller designing.

TABLE I. SPECIFICATION OF IBDG IN ISLAND MODE

Specification of IBDG in island mode	
DG characteristics	Parameters
DC voltage	10 pu
Output ac voltage	1.05 pu
X_L (inverter side)	0.01708p.u.
X_C	1.009pu

X_L (grid side)	0.003p. u
OUTPUT ACTIVE POWER	0.6 -0.8 pu
OUT REACTIVE POWER	-

Ziegler Nichols method is not possible to apply in nonlinear systems. To apply these methods, non linear system is first converted into equivalent linear system. Then the value of PID controller is used. This method is simple but not efficient as sometimes design of equivalent linear model cannot be possible. Analysis is done on time domain basis.PI/PR controller can be formulated as a single objective optimization problem which depends on time domain indices integral. The objective function is made to focus on the steady state error minimization in this work [24].By using optimization technique K_p, K_i for PI and K_p, K_i and K_v for PR controller will be found . The range of the gain value when set in between 1 to 20 provides the best results.

B. Grid Connected Mode of Operation

For grid connected mode of operation a reduced voltage is applied. In island operation entire load is supplied by DG and here only 20 MW is supplied by the DG.Specification of inverter based DG is given in Table II. A three phase fault is applied at bus 12. Fault current is measured from the system.

TABLE II. INVERTER BASED DG SPECIFICATION WITH GRID CONNECTED MODE

Specification of IBDG in grid connected mode	
DG characteristics	Parameters
Switching frequency	30KHZ
DC voltage	3 pu
Output ac voltage	1 pu
X_L (inverter side)	0.01708p.u.
X_C	1.009pu
X_L (grid side)	0.003p. u
OUTPUT ACTIVE POWER	0.2 pu
OUT REACTIVE POWER	0.01 pu
Harmonic	2.639%

IV. RESULTS AND DISCUSSION

A. Island Mode

In island mode the system is disconnected from the grid. In this work bus 8 to bus 14 was separated from the grid as shown in Fig. 4.In this mode if a bolted three phase fault is applied for 0.01 to 0.05 sec at bus 12,resulting fault current and bus voltage for every bus are shown below in Table III and Table IV. Before fault, the rated output current is 0.6 p.u obtained from the inverter. Inverter is operated

in voltage control mode. Voltage sag during fault is also shown below in Table IV.

TABLE III. FAULT CURRENT (IN PU) IN ISLAND MODE

Fault current (in pu) in island mode	
Fault bus	12
Fault current at bus 12	0.41pu
Fault current from IBDG	0.8pu

TABLE IV. VOLTAGE AFTER AND BEFORE THREE PHASE FAULT

Voltage after and before three phase fault		
Bus no.	Fault voltage (p.u)	Voltage before fault(p.u)
8	1.04	1.05
9	0.7	1
10	0.6	0.95
11	0.6	0.9
12	0	0.88
13	0.175	0.85
14	0.4	0.9

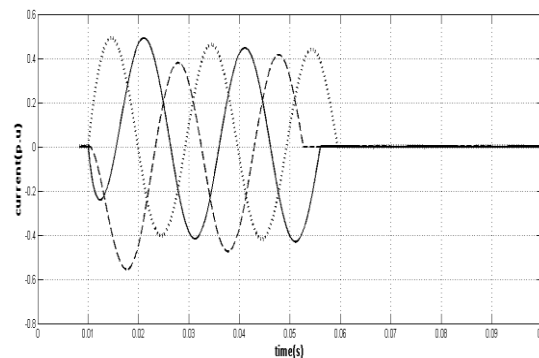

Fig. 5. Fault current (in pu) in island mode(time in sec)

Fault current in island mode is shown in Fig. 5. The value of $K_p=19.9781$, $K_i=9.636243$, and $K_v=2.78774$ for PR controller is found by optimization.For PI controller, the value of $K_p=1.9497$ and $K_v=2.5477$ is found.Harmonics is found to be in between 1.2 % and 1.33%.

From the above Fig 5 it is found that the current contribution from IBDG is 0.8 p.u,which is only 133 % percent above the rated current. For higher efficiency of controller, harmonic presence in the system is also minimized. If it is operated by other type of DG like Synchronous based DG (SBDG),the current contribution must be above this [5]. IBDG have a current limiting capacity which is discussed previously. If it is operated grid connected mode then

fault current may be high. To show this grid connected operation is done.

B. Grid Connected Mode

A three phase fault is applied at bus 12 for 0.1 sec to 0.5 sec without DG and the current wave forms are observed. Simulation models developed for IBDG are then connected to the network at bus 8 by replacing the synchronous condenser. IBDG is operated in voltage control mode for grid connected mode which is previously discussed and fault current is also measured thus considering all the dynamics, fault current and voltage sag during fault is try to find out in this work.

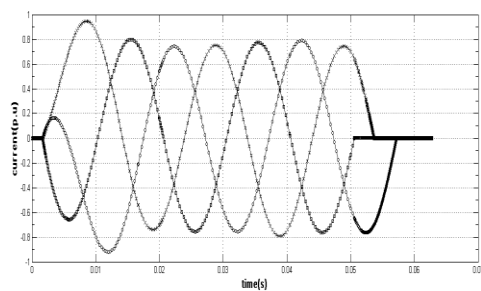

Fig. 6. Fault current (in pu) without DG (time in sec)

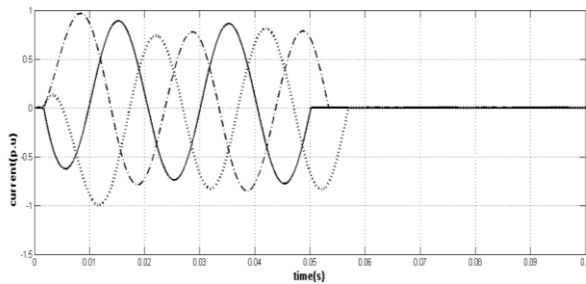

Fig. 7. Fault current (in pu) with IBDG (time in sec)

From Fig. 6 and Fig. 7, it is found that fault current is maximum for IBDG and minimum for the system without DG in grid connected mode. Voltage sag is also minimum for IBDG during fault. Since IBDG is operated at voltage regulated mode, IBDG wants to keep the voltage constant. So voltage deviation is minimum by regulating the reactive power. It can therefore supply constant active power but variable reactive power. In case of system without DG operation, synchronous condenser is present in the system of standard IEEE14 bus network at bus no 8. So in this case also voltage deviation is minimum at bus 9. Pre fault, post fault voltage for every bus and fault current is shown in Table V and VI.

TABLE V. FAULT CURRENT (IN PU) AT BUS 12 IN GRID CONNECTED MODE

Fault current (in pu) at bus 12 in grid connected mode	
DG	fault current(p.u)
NO DG	0.8
With IBDG	0.9

When IBDG is grid connected, it is operated at voltage control mode with active power control. The current supplied by the IBDG can be a maximum up to 1.3 to 1.5 of rated current. Presence of alternator helps to give fault current up to 5 times the rated current. But here DG penetration level is only 7%. If penetration level is increased, fault current level may also increase. But voltage controller circuit operates to keep constant voltage at the output. So voltage sag is also minimized. Another impact of IBDG is that it increases the harmonics of the input fault current. For protection system designing of a low pass filter is considered otherwise protection device cannot identify or differentiate the temporary fault and permanent fault.

TABLE VI. VOLTAGE AFTER AND BEFORE THREE PHASE FAULT

Voltage after and before three phase fault			
Bus no	Bus voltage after fault		Pre fault voltage
	WithoutDG(pu)	With IBDG(pu)	Without DG (pu)
1	0.8	0.86	1.060
2	0.79	0.85	1.045
3	0.7	0.83	1.010
4	0.58	0.8	1.0334
5	0.6	0.68	1.0301
6	0.42	0.56	1.0700
7	0.47	0.7	1.1225
8	0.4	0.9	1.0900
9	0.7	0.75	1.0847
10	0.401	0.6	1.0749
11	0.362	0.4	1.0693
12	0	0	1.0572
13	0.27	0.4	1.0547
14	0.214	0.6	1.0540

From the above result it is also found that for same load response the fault current is less for island mode. In this work, only IBDG is present and this does not give the fault current above 1.33 unit of rated current. Therefore the current is limited altogether. So a different suitable protection system will be required for this purpose.

V. CONCLUSION

In this work, the impact of installation of DGs in distribution systems is discussed for the protection purpose. Computation of fault current by applying the Z bus matrix may not be appropriate due to the complexity in guessing the transient impedance of the inverter based DGs. A simulation strategy can be applied to calculate the fault current and a comparative analysis is made between the grid connected mode and island mode with varying IBDG output. It is found that a different protection coordination is required for grid connected and island mode of operation.

ACKNOWLEDGMENT

The author would like to express his gratitude to the Department of Electrical Engineering, University of Engineering and Management, Kolkata for the necessary help.

REFERENCES

- [1] Zavandehroodi. Hadi. Amr Mohamed. Hussain Shareef. Marian Mohammadiafari. and Masoud Farhoodnea. "A novel protection coordination strategy using back tracking algorithm for distribution systems with high penetration of DG." In *Power Engineering and Optimization Conference (PEOCO)* Melaka, Malaysia. 2012 Ieee International. IEEE, 2012, pp. 187-192
- [2] Ackermann T, Knyazkin V. "Interaction between distributed generation and the distribution network: operation aspects." In: *IEEE Transmission and Distribution Conference and Exhibition 2002, Asia Pacific*; October 2002.
- [3] Conti S., "Analysis of distribution network protection issues in presence of dispersed generation." *Electr Power Syst Res J* January 2009;79(1):49-56.
- [4] Y. Firouza. S. Farhadkhanib. J. Lohrvh. F. Valléc. A. Khaknourd. O. Durieux "Numerical comparison of the effects of different types of distributed generation units on overcurrent protection systems in MV distribution grids", *Renewable Energy* 69 (2014) ,pp271-283
- [5] Sunannon. Autthanorn. Peeranol Jiranong. Panida Thararak. and Sattawat Burana. "Recloser-fuse coordination improvement for distributed generation installed capacity enhancement in electrical distribution systems". In *Electrical Engineering/Electronics, Computer, Telecommunications and Information Technology (ECTI-CON)*. 2015 12th International Conference on. IEEE, 2015, pp. 1-6.
- [6] K. Kumpulainen. K.T. Kauhaniemi. "Analysis of the impact of distributed generation on automatic reclosing". in: *Power Systems Conference and Exposition IEEE PES*, vol. 1, 2004, pp. 603-608.
- [7] Sa'ed. J. A.. Salvatore Favuzza. M. G. Innolito. and F. Massaro. "Verifying the effect of distributed generators on voltage profile, power losses and protection system in radial distribution networks." In *Power Engineering, Energy and Electrical Drives (POWERENG)*. 2013 Fourth International Conference on, IEEE, 2013, pp. 1044-1049.
- [8] Funmilayo. Hamed B.. and Karen L. Butler-Purry. "An approach to mitigate the impact of distributed generation on the overcurrent protection scheme for radial feeders." In *Power Systems Conference and Exposition, 2009. PSCE'09. IEEE/PES*, pp. 1-11.
- [9] X Wang X Ruan S Liu C K Tse "Full feed forward of grid voltage for grid connected Inverter with LCL filter to suppress current distortion due to Grid voltage harmonics" *IEEE Transactions on Power Electronics* 25 (2010) pp 1398-1409.
- [10] Dannehl. Joerg. Marco Liserre. and Friedrich Wilhelm Fuchs. "Filter-based active damping of voltage source converters with filter" *IEEE Transactions on Industrial Electronics*, 58, no. 8 (2011),pp.3623-3633.
- [11] Jeong. Hea-Gwang. Kvo-Beum Lee. Sewan Choi. and Woojin Choi. "Performance improvement of LCL-filter-based grid-connected inverters using POR power transformation." *Power Electronics. IEEE Transactions on* 25, no. 5 (2010).pp. 1320-1330.
- [12] Turner. Robert. Simon Walton. and Richard Duke. "Stability and bandwidth implications of digitally controlled grid-connected parallel inverters." *Industrial Electronics. IEEE Transactions on* 57, no. 11 (2010).pp. 3685-3694.
- [13] Borghetti. A.. R. Caldon. S. Guerrieri. and F. Rossetto. "Dispersed generators interfaced with distribution systems: dynamic response to faults and perturbations." In *Power Tech Conference Proceedings. 2003 IEEE Bologna*, vol. 2, pp 6-pp. IEEE, 2003.
- [14] Brucoli. Maria. Tim C. Green. and John DF McDonald. "Modelling and analysis of fault behaviour of inverter microgrids to aid future fault detection." In *System of Systems Engineering. 2007. SoSE'07. IEEE International Conference on*, IEEE, 2007, pp. 1-6.
- [15] Y.W.Li and C.N Kao, "An accurate power control strategy for power electronics interfaced distributed generation units operation in low voltage multibus microgrid" *IEEE Transaction on Power Electronics* , vol 24. No 12, Dec. 2009, pp 2977-2988
- [16] Se-Kvo Chung "A phase tracking system for three phase utility interface inverters" *IEEE Trans. Power Electronics*, Vol. 15, No.3, 2000, pp. 431-438.
- [17] Yun Wei Li. "Control and Resonance Damping of Voltage-Source and Current-Source Converters With LCL Filters." *Industrial Electronics. IEEE Transactions on* , vol. 56, no,5, , May 2009, pp, 1511-1521.
- [18] L. M. Guerrero. I C. Vasquez. I Matas. L. G. de Vicuna. and M. Castilla. "Hierarchical control of droop-controlled ac and dc microgrids-A general approach toward standardization." *IEEE Trans. Ind. Electron*" vol. 58, no, I, Jan, 2011, pp, 158-172.
- [19] M. Y. Park. M. H. Chi. J. H. Park. H. G. Kim. T. W. Chun and E. C. Nho "LCL-filter design for grid-connected PCS using total harmonic distortion and ripple attenuation factor" in *Proc. Int. Power Electron. Conf.*, 2010, pp. 1688-1694.
- [20] E. Twining and D. G. Holmes "Grid current regulation of a three-phase voltage source inverter with an LCL input filter," *IEEE Trans.*

- Power Electron., vol. 18, no. 3, May 2003 pp. 888–895.
- [21] Woei-Luen and Jhe-Shuan Lin “One-Dimensional Optimization for Proportional-Resonant Controller Design Against the Change in Source Impedance and Solar Irradiation in PV Systems” IEEE transactions on industrial electronics, VOL. 61, NO. 4, APRIL 2014, pp 1845-1854
- [22] Natthanhob Nimpitiwan . Geraldthomas Hevdt. Raia Avvanar . and Siddharth Suryanarayanan, “Fault Current Contribution From Synchronous Machine and Inverter Based Distributed Generators” IEEE TRANSACTIONS ON POWER DELIVERY, VOL. 22, NO. 1, JANUARY 2007, pp 634-642
- [23] http://shodhganga.inflibnet.ac.in/bitstream/10603/5247/18/19_appendix.pdf
- [24] Aneguluri Rajasekhar a . Ravi Kumar Jatoh b . Aiiith Abraham. “Design of intelligent PID/niλ Du sneed controller for chopper fed DC motor drive using opposition based artificial bee colony algorithm” Engineering Applications of Artificial Intelligence 29 (2014) ,pp.13–32