

# Transport Refrigeration

Faisal A Alshaye, Yousef Y Al houli

## Abstract

Refrigeration trucks are a special application for air conditioning. In this paper I shall talk about the systems used for refrigeration trucks. How they are insulated. How they are recharged . I selected a truck for the purpose of illustrating the following  
 Power of compressor  
 Power of Condenser  
 calculate the cooling load  
 insulation requirements

Date of Submission: 05-02-2020

Date Of Acceptance: 20-02-2020

## I. Introduction

Refrigerating transport is a special application of air conditioning. It is essential for transporting heat sensitive products like for example fruits, vegetables and. Ice cream the products get refrigerated while they are being moved from one destination to the other by ships, trucks, airplanes or trains. Here we are going to talk about the trucks. There are many systems for truck refrigeration One of the oldest ways is simply using an insulated truck that contains blocks of ice. This is only good for short time rides Dry ice is another option for refrigeration. Another way is to utilising liquefied CO<sub>2</sub> [Carbon dioxide] or liquefied N<sub>2</sub> [Nitrogen]. Or make use of an air condition unit and this type is referred to as self-contained.

Different loads have different temperature requirements.

The elements we need to know to determine the best transport system are  
 The type of products: fresh fruits or frozen food.  
 How much the load weighs.  
 The weather throughout the trip.  
 The dimensions of the truck  
 Type and thickness of the insulation

Throughout the paper I will give example. for how to calculate cooling loads and other factors of the cooling system

### Below are the specific parameters of my selection

- Given weight 2.0 Ton
- Cooled box weight 1.0 Ton
- Refrigeration machine weight 0.5 Ton
- Products weight .01 ton
- Weight of 2 persons that unload and load the truck 0.15 Ton
- Four-cylinder water cooled diesel engine.
- Overall heat transfer coefficient
  - U = .01767 W/m<sup>2</sup>. K
- Dimension of cooled box 6.5 \* 2.5 \* 2.1
- Surface area of the cooled box
  - A [m<sup>2</sup>] = 70.3 m<sup>2</sup>.
- Temperature
  - Outside: maximum 40 °C
  - Inside: minimum -18 °C.

## Greek Symbols

δ:	Thickness	m
Δt:	Temperature difference	<sup>0</sup> C
P:	Density	Kg/m <sup>3</sup>
τ:	Time	Hour
η:	Volumetric efficiency	
η <sub>i</sub> :	Indicated efficiency	
η <sub>m</sub>	Mechanical efficiency	

A	: Heat transfer surface area	m <sup>2</sup>
C <sub>p</sub>	: Heat capacity	Kj/kg.°C
G	: Weight of the product	Kg
h <sub>i</sub>	: Inner wall surface heat transfer coefficient	W/m <sup>2</sup> K
h <sub>o</sub>	: outer wall surface heat transfer coefficient	W/m <sup>2</sup> K
I	: Enthalpy	Kj/kg
k <sub>j</sub>	: Thermal conductivity of insulation material	W/m.k
k <sub>st</sub>	: Thermal conductivity of galvanized steel	W/m.k
N <sub>a</sub>	: Adiabatic power	W
N <sub>e</sub>	: Effective power	W
N <sub>m</sub>	: Effective mechanical power	W
Nu	: Nusselt number	
Q <sub>o</sub>	: Cooling	W
Q <sub>c</sub>	: Condenser load	W
Q <sub>inf</sub>	: infiltration load	W
Q <sub>p</sub>	: Product load	W
Q <sub>ser</sub>	: Service load	W
Q <sub>s.r</sub>	: Solar and road heat	W
Q <sub>ot</sub>	: Cooling	W
Q <sub>w</sub>	: Wall gained load	W
q <sub>o</sub>	: refrigeration effect	Kj/kg
Re	: Reynolds number	
t <sub>c</sub>	: Condensation temperature	° C
t <sub>ins</sub>	: Design box temperature	° C
t <sub>o</sub>	: Evaporation temperature	° C
t <sub>out</sub>	: Maximum ambient temperature	° C
t <sub>s</sub>	: Evaporation pressure	° C
U	: Overall heat transfer coefficient	W/m <sup>2</sup> °C
V	: Volume	m <sup>3</sup>
v <sub>i</sub>	: Specific volume	m <sup>3</sup> /kg

### 1.1 Ways to refrigerate trucks.

One of the simplest systems still in use is to thoroughly engulf the products in ice blocks. This way holds the products temperature just above freezing. It works best for short time periods in well insulated vehicles. During the ride the ice melts producing water, that has to be dealt with .Picture 1.1

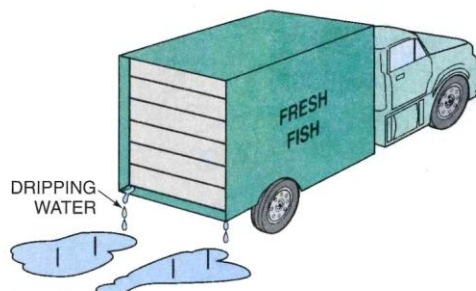

**Figure 27-2** When ice is used for preserving products, it melts and often leaves a trail of water on the highway or a puddle in a parking area.

**Picture 1.1** Water on the road is a result of the melting ice.

The result product when we solidify and compress carbon dioxide, is dry ice. We can use it for Short haul rides. Since the dry ice is too cold, it is in a way hard to keep the temperature of the load at the right level. Sublimation of dry ice [changing from solid to vapour without turning to liquid] occurs at -109 F. Dehydration is the main problem when we use dry ice, thus the product must be packed in airtight containers .

### 1.1.2 Liquid nitrogen & liquid CO<sub>2</sub> systems

Liquid carbon dioxide and liquid nitrogen is another way to refrigerate the products. The nitrogen in this case stored in a low pressure cylinder, after it has been refrigerated then condensed to liquid. In case the inside pressure of the cylinder became more than 25 psig, a relief valve on the cylinder releases vapour. That reduces the pressure and the temperature of the cylinder, by boiling some of the liquid remaining inside it , Picture 1.2 .

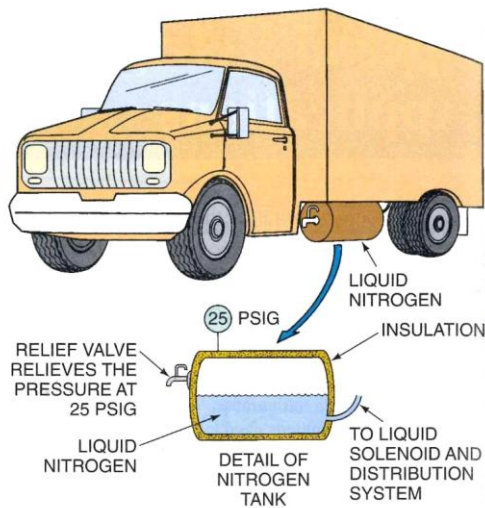

Figure 27-3 Nitrogen cylinder maintained at about 25 psig.

Picture 1.2 Nitrogen cylinder kept around 25 psig.

Both the product and the air in the vehicle are cooled by the release of the liquid piped in the manifold that contain the refrigerated product. The nitrogen line has A solenoid valve that controls the flow of the liquid. The valve is controlled by the thermostat located in the product space, Picture 1.3 .

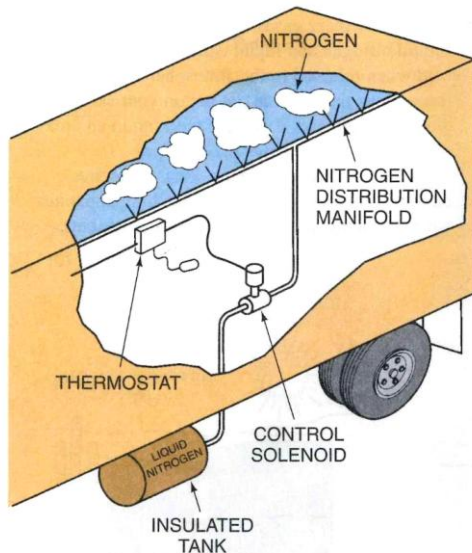

Figure 27-4 Control for a liquid nitrogen cooling system.

Picture 1.3 Liquid nitrogen refrigeration system control

To ensure even disperse of cold vapor we may use fans.  
 Since nitrogen is already a main component of air [78%], it is safe to release it to the atmosphere.  
 Liquid CO 2refrigerating system works in the same manner as the liquid nitrogen system. Take in consideration that the boiling point of CO 2is -109° F.

Proper controls make it possible to utilise these two very cold liquids with medium temperature products. The controls include an accurate thermostat to read the temperature of the refrigerated space, and a refrigerant distribution system

### 1.1.3 Cold plates

Cold plates or in other words refrigerated plates are installed in many trucks. They are 1-3 inches thick, used to maintain the correct temperature for medium & low temperature products. The plates are filled with eutectic solution. It is a brine solution [consists of sodium or calcium chloride], The brine causes matters to change their state, as a result each pound of material absorbs more heat.

Different concentration of the brine helps us reach eutectic temperature. Various concentrations cause formation of salt crystals at different temperatures.

We have to insure that The air flows smoothly around the plates, which are either mounted on the walls or on the ceiling of the vehicle, Picture 1.4 .

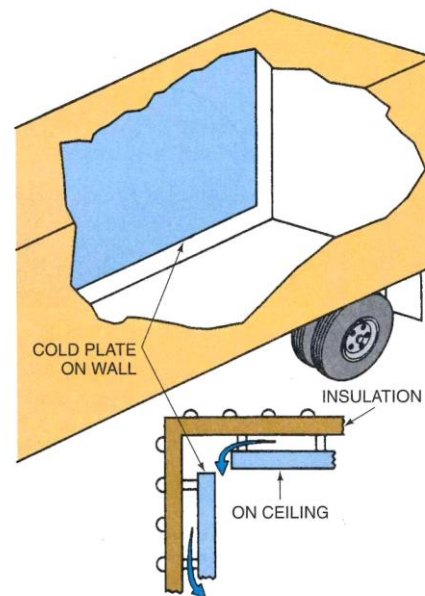

Figure 27-5 Cold plates mounted in a truck body.

Picture 1.4 Cold plates installed on truck walls

The plates receive heat from the room air. The brine absorbs heat and while it changes solid state to liquid. The brine will change form to solid when the plates are cooled during recharge.

#### 1.1.3.1 Refrigerant researching method

Refrigerants like R-134a , ammonia, or R-012 may be used for recharging the plates at loading dock , Picture 1.5

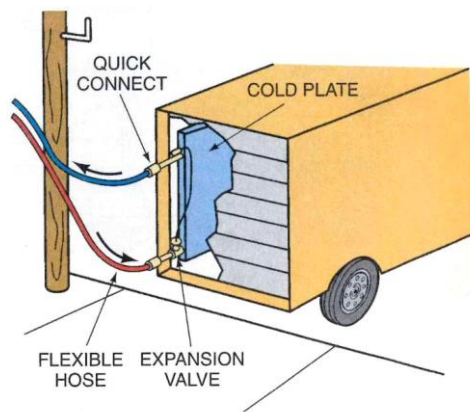

**Figure 27-6** Cold plate connected to the refrigeration system at the dock.

**Picture 1.5** The connection between the cold plate and the refrigeration system at the loading dock

The plate contains direct expansion coil (it can be located either on the plate itself or on the loading dock), it connects the recharging system. At the loading dock after the vehicle backs up hoses connect the truck to the central refrigeration system. the central refrigeration makes the pressure inside the evaporator drop to allow the liquid brine solidify within few hours.

1.1.3.2refrigerated brine method.

Refrigerated brine is another method used to recharge the cold plate. This method also requires quick connect fixtures to connect to the truck at the loading dock.

The cold brine which is refrigerated at a temperature much lower than the cold plate circulates through a coil located in the cold plate. This will freeze the brine inside the cold plate.

1.1.4On truck refrigeration system

The other method that may be used to refrigerate trucks is to mount a refrigeration system on the truck. Each system requires a power supply. Different vehicle types use different power sources.

1.1.4a vans utilise a refrigeration compressor under hood refrigeration compressor. The van engine turns the compressor. A thermostat controls an electric clutch that cycles the compressor which controls the refrigeration ,Picture 1.6

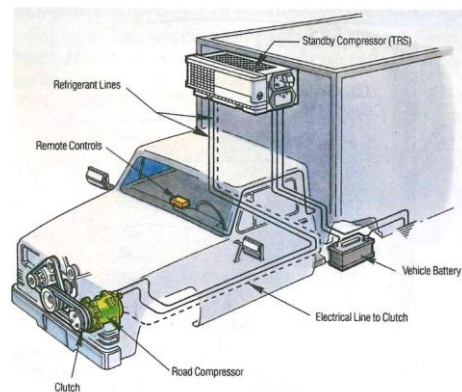
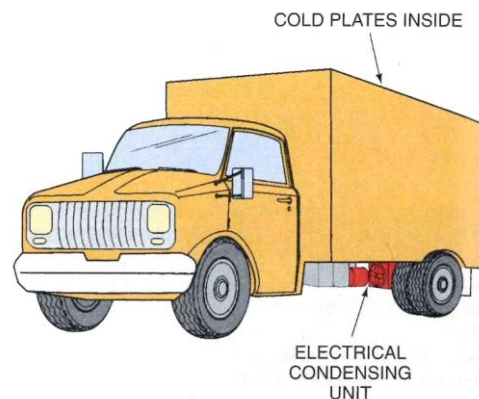

**Figure 27-7** This truck refrigeration is driven from the truck's engine and may be cycled by means of an electric clutch. Reproduced courtesy of Carrier Corporation

**Picture 1.6** truck engine drives the truck refrigeration and may be cycled via an electric clutch

As long as the vehicle is running this method works well. While the engine is not running a compressor driven by an auxiliary electric motor may be plugged at the loading dock.

1.1.4b Some trucks have a small belly mount condensing unit. It recharges the cold plate while the truck is at the loading dock ,Picture 1.7



**Figure 27-8** The truck uses a small refrigeration system on the truck to recharge the cold plates while parked at night.

**Picture 1.7** The cold plates are recharged while the truck is parked by a small refrigeration system

When the truck is moving a small generator powers the condensing unit. The motor generator is placed below the chassis; it has either a diesel or gas engine. The engine turns the generator to generate 60 cycle, 230v current to run the compressor. Diesel engines are more economic on the long run. In some cases, a generator with sophisticated control produces 230v from truck engine.

1.1.4c large trucks have either under belly or nose mounted units. The units may be operated by either a motor generator driven via a diesel engine or a compressor driven diesel engine ,Picture 1.8



Figure 27-9 (A) Nose-mount and (B) belly-mount refrigerated truck. Reproduced courtesy of Carrier Corporation

Picture 1.8 A] Nose mounted B] Belly mounted refrigeration truck.

The engine controls the compressor speed. Say it is a low and high two speed system, unloading cylinders on the compressor controls the compressor.

For example, if we have a four-cylinder compressor with one-ton capacity per cylinder. We may operate the compressor from one to four tons by unloading cylinders Picture 1.9

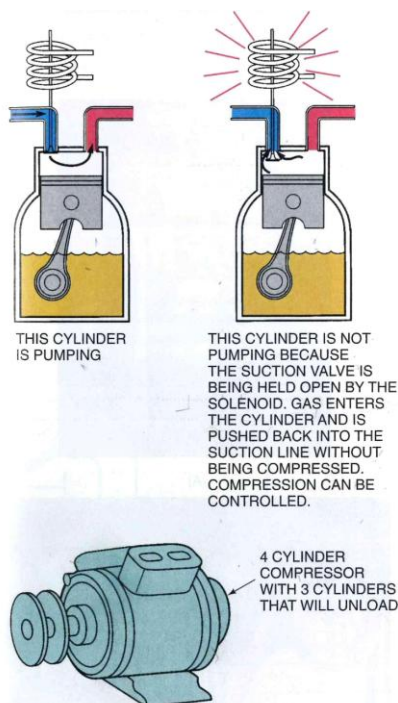
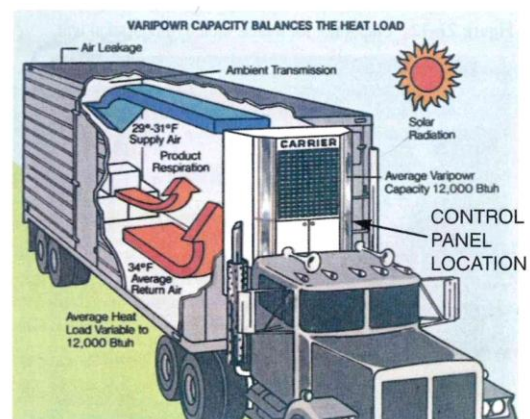

Figure 27-10 Capacity control for a compressor.

Picture 1.9 Compressor capacity control

To avoid cycling the diesel engine on and off at least one-ton load is the minimum required load. Though it is preferred for the engine to run continuously, they stop and start automatically now. Picture 1.10



(A)

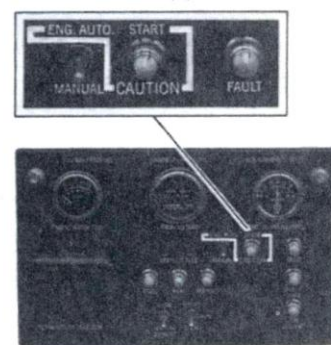

(B)

Figure 27-11 (B) Automatic control to stop and start a truck refrigeration system. (A) Shows location of panel. Reproduced courtesy of Carrier Corporation

Picture 1.10 A] Panel location

B] refrigeration system automated stop and start  
 Typically, the evaporator is placed at the front blowing air to the back.  
 Picture 1.11

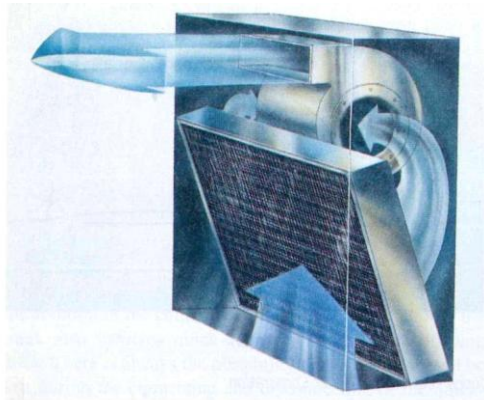

Figure 27-12 Evaporator for a nose-mount refrigeration unit.

Picture 1.11 Evaporator of a nose mounted unit.

A centrifugal fan blows with high velocity a high quantity of air to ensure it reaches the back ,Picture 1.12

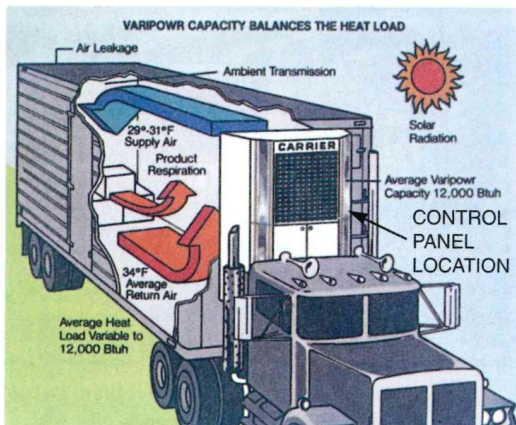

Figure 27-13 Air distribution system for truck. *Reproduced courtesy of Carrier Corporation*

Picture 1.12 Truck air distribution.

The engine which drives the compressor also drives the fan, the fan is also driven with gear boxes and belts. For the sake of easy access hence, easy service, all those components are placed inside the access door ,Picture 1.13



Figure 27-14 Access for service for a nose-mount unit. *Courtesy Thermo King Corp.*

Picture 1.13 Nose mounted unit service access.

The condenser fan is a prop type one, which also is driven by the same drive ,Picture 1.14

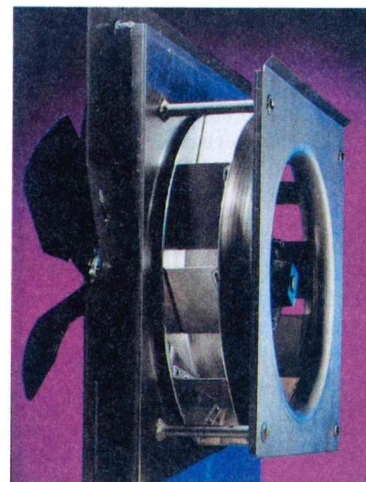

(A)

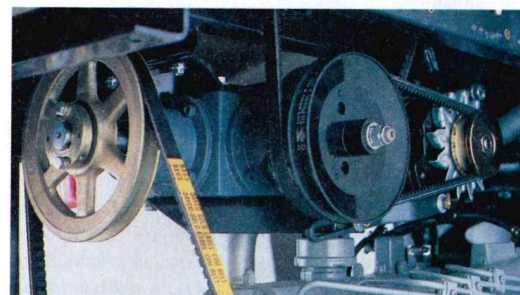

(B)

Figure 27-15 (A)-(B) Fan drive mechanisms. *Courtesy (A) Thermo King Corp, (B) Carrier Corporation*

Picture 1.14 Mechanism of fan drive

The refrigeration system has to be lightweight and that is why many parts are made of aluminium.

### 1.2 Load temperature.

Refrigeration system is supposed to maintain the load at the desired temperature and not cool it down. That is why we have to make sure the load is already at the desired temperature at the loading time,

### 1.3 Truck insulation

1.3a To prevent the heat from getting into the truck, we spray foam insulation on the walls of the truck and fasten wallboard on the foam, Picture 1.15

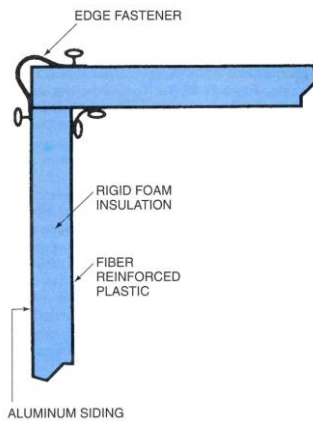

Figure 27-18 Sandwich construction for truck walls.

**Picture 1.15** Sandwich construction of the truck wall

1.3b The doors of the vehicle must be completely sealed to prevent outside air from entering the truck

### 2.1 The cooling load calculation

#### 2.1.1 Introduction

The cooling load on refrigerating equipment seldom results from any one single source of heat. Rather, it is the summation of the heat which usually involved from several different sources. Some of the more common sources of heat that supply the load on refrigerating equipment of the refrigerating truck will be shown through the calculation process.

#### 1.4.2 Data for Calculations

-Truck box dimension 6.5\*2.5\*2.1m

-Polyurethane insulating material with thickness 125 mm.

-The thermal conduction

the maximum outside temperature 40°C

the minimum inside temperature -18°C

-The overall coefficient of heat transfer  $U = 0.1767$  W/m<sup>2</sup>K

-Truck box surface area  $A = 70.3 = 2m^2$

#### 1.4.3 Cooling Load

Wall gained load

Solar and road load by the rear is recommended as follows

Product load

where

-G: the weight of product = 10 ton of frozen chicken

-the inlet and outlet enthalpy of the product at (-8, -18°C),

-the maximum required time during which the product achieves -18°C is equal 4 hours

The cooling load due to air infiltration :

where

-n: factor indicating to the fraction of box volume air changing during 1 hour = 0.8

-V: Internal box volume = 27.531 m<sup>3</sup>

-the heat capacity of the air

(1.02) = kJ/ kg.K

-the air density = 1,128 kg/m<sup>3</sup>

Service load

By the recommendation of the Thermo-King Company moderate service, the service load can be determined as :

The total cooling load

$$8550.3 = 810.5 + 270.3 + 6388.8 + 360.2 + 7250 = W$$

The actual cooling load

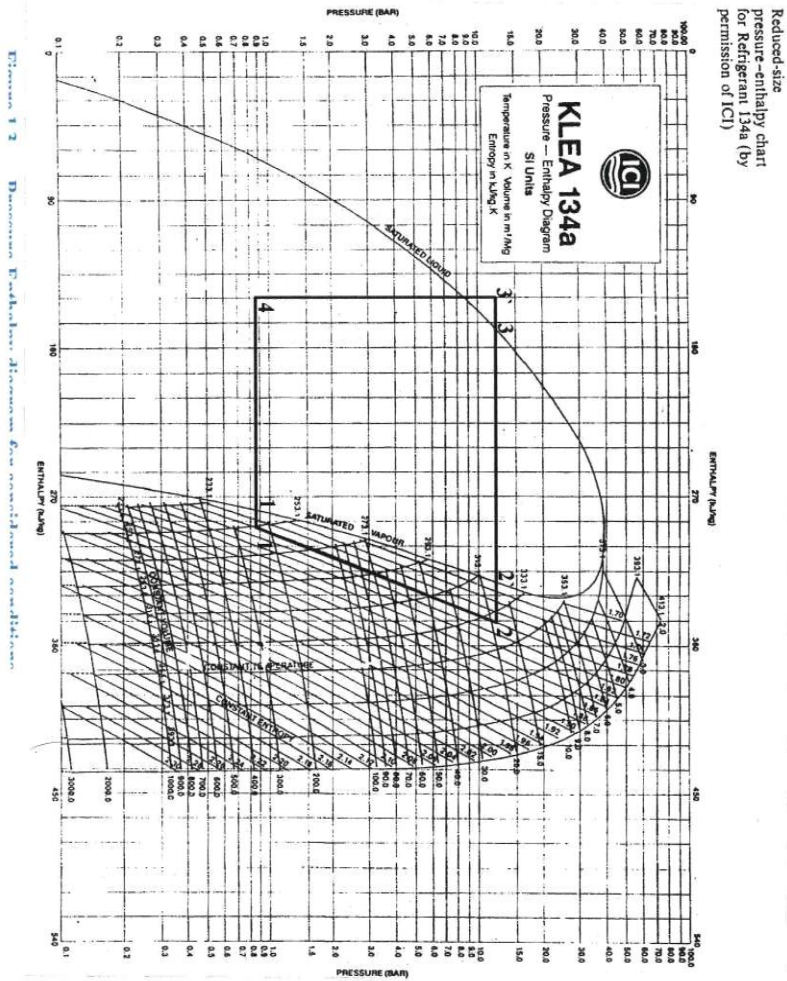

Table 1 .The characteristic of the cycle points

Charts Points	t oC	P MPa	V m <sup>3</sup> /kg	I KJ/kg
1	30-	0.85	-	275
1'	20-	0.85	0.250	285
2	66	1.16	-	345
2'	45	1.16	-	320
3	45	1.16	-	170
3'	35	1.16	-	150
4	30-	0.85	-	150



1.5.1 Determination of the Mechanical Power of the Compressor :

Specific refrigerating capacity :

$$125 = 150 - 275 = \text{kJ/kg}$$

The mass of the circulating refrigerant :

G

$$0.07524 = 125/9405 = \text{kg/sec}$$

The actual volume of the vapor entering to the compressor :

$$V_o = G \cdot v_g$$

$$0.01881 = 0.25 \cdot 0.07524 = \text{m}^3/\text{sec}$$

The adiabatic compression power :

The indicated power :

where

Indicated efficiency ranges from 0.74 to 0.82

The effective (mechanical) power

where

the mechanical efficiency & equal 0.8

1.5.2 The Condenser Calculations

The condenser load :

The condenser heat transfer surface area :

where

A = The condenser outer heat transfer area()

= The condenser heat load (W)

U = The overall heat transfer coefficient for air cooled condenser

( 50 - 30)

$$q_f = U \cdot \Delta T = 40 \cdot 10 = 400$$

qf = The specific heat load of the condenser for the condenser with forced air motion.

1.5.3 The Evaporator Calculations

The heat transfer surface area :

$$A = Q_o / U$$

$$19.6 = (12 \cdot 40) / 9405 =$$

where

A: the heat transfer surface area()

Qo : the refrigerating capacity of the evaporator

$$9405 = W$$

U: the overall coefficient of heat transfer is assumed according to the boiling temperature and the type of the evaporator, for air cooling with bare-tube and velocity of (3 ..5) m/sec

$$43 \dots 35 =$$

t: the temperature difference of the boiling refrigerant and cooled space = 12oC

3.1 Insulation calculation

Introduction

Since heat will always transfer from a region of high temperature to a region of low temperature, there is always a continuous flow of heat into the refrigerated space from warmer surroundings. To limit the flow of heat into the refrigerated box to some practical minimum, it is usually necessary to insulate the box from its surroundings with a good heat-insulating material.

1.2.2 Insulating Material Selection

For the case of truck polyurethane was recommended as insulating material for the following advantages :

Low thermal conductivity.

Low moisture vapour permeability.

High strength to weight ratio.

Dimensional stability.

High temperature resistance till 120oC

Durability.

Imperviousness to fungi, acids and alkalis.

Economic.

Easy application.

1.2.3 The Heat Transfer of the Outside Wall

\*Data for calculations :

The maximum outside temperature 41 oC

The minimum inside temperature 18-oC

The thermal conductivity of the picked steel sheet

Kst 49 = W/m.K

The inner heat transfer coefficient is recommended as

$$h_i = 18 \text{ W/m}^2\text{K}$$

The thickness of the outside and inside picked steel sheet are 1 and 0.6mm, respectively.

The outer heat transfer coefficient is determined, taking into consideration the worst conditions when the truck is completely stopped at an air temperature equal to 41oC. Thus ho = 6 = W/m.2K.

1.2.4 The construction of Wall :

1.2.4. The Construction of Wall:

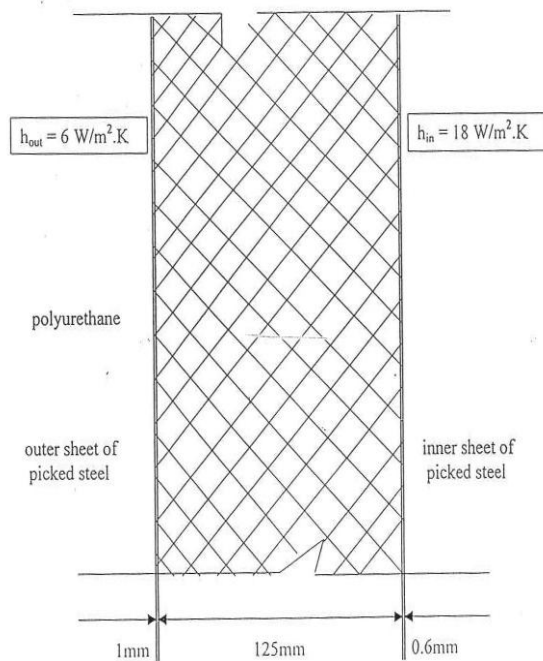

Figure 1.1

The overall coefficient of heat transfer “U”

hence

$$U = 0.1767 \text{ W/m}^2\text{K}$$

$h_{out}$  and  $h_{in}$  are taken to be 6 and 18  $\text{W/m}^2\text{K}$  respectively.

**REFERENCES**

[1]. Refrigeration & Air Conditioning Technology  
 [2]. Figure 27-2 When ice is used for preserving products, it melts  
 [3]. Figure 27-3 Nitrogen cylinder maintained at about 25 psig.  
 [4]. Figure 27-4 Control for a liquid nitrogen cooling system.  
 [5]. Figure 27-5 Cold plates mounted in a truck body.  
 [6]. Figure 27-6 Cold plate connected to the refrigeration system at the dock.  
 [7]. Figure 27-7 This truck refrigeration is driven from the truck’s engine and may be cycled by means of an electric clutch.  
 [8]. Figure 27-8 The truck uses a small refrigeration system on the truck to recharge the cold plates while parked at night.  
 [9]. Figure 27-9 (A) Nose-mount and (B) belly-mount refrigerated truck. Reproduced courtesy of Carrier Corporation.

[10]. Figure 27-10 Capacity control for a compressor.  
 [11]. Figure 27-11 (B) Automatic control to stop and start a truck refrigeration system. (A) Shows location of panel. Reproduced courtesy of Carrier Corporation.  
 [12]. Figure 27-12 Evaporator for a nose-mount refrigeration unit .  
 [13]. Figure 27-13 Air distribution system for truck. Reproduced courtesy of Carrier Corporation.  
 [14]. Figure 27-14 Access for service for a nose-mount unit. Courtesy Thermo King Corp.  
 [15]. Figure 27-15 (A)-(B) Fan drive mechanisms. Courtesy (a) Thermo King Corp, (B) Carrier Corporation.  
 [16]. Figure 27-18 Sandwich construction for truck walls.