

Performance Improvement of power system with Power Quality Features Using Hybrid (Solar Wind) Energy.

*Mandadi Surender Reddy¹, Ganji Vivekananda²

¹is a research scholar in department of Electrical Engineering in Sunrise University, Rajasthan, India.

²is a research scholar in department of Electrical and Electronics Engineering in Acharya Nagarjuna University, Guntur, Andhra Pradesh, India.

Corresponding author: *Mandadi Surender Reddy

ABSTRACT

This paper presents analysis and improvement of power quality (voltage sag, swell and harmonics) performance of smart grid connected inverter used in distributed generation. The structure of the designed controller consists of outer power with harmonic control loop, middle voltage control loop and inner current control power loop for real and reactive power control in dq reference frame. The developed controller controls the real and reactive power supplied by the DG (Distributed Generation) at the PCC (Power Controlled Converter). The controller is designed to deliver current at unity power factor at PCC. An increase in reactive power demand and harmonics at PCC due to change of load and grid impedance variation, would affect the system voltage at PCC. Renewable energy resources (RES) are being increasingly connected in distribution systems utilizing power electronic converters. This report presents a novel control strategy for achieving maximum benefits from these grid-interfacing inverters when installed in 3-phase 4-wire distribution systems. The inverter is controlled to perform as a multi-function device by incorporating active power filter functionality. The inverter can thus be utilized as:

- 1) Power converter to inject power generated from RES to the grid, and
- 2) Shunt APF to compensate current unbalance, load current harmonics, load reactive power demand and load neutral current.

All of these functions may be accomplished either individually or simultaneously. With such a control, the combination of grid-interfacing inverter and the 3-phase 4-wire linear/non-linear unbalanced load at point of common coupling appears as balanced linear load to the grid. This new control concept is demonstrated with extensive MATLAB/Simulink simulation studies and validated through digital signal processor-based. The comparisons have been made with the conventional SVPWM based PI controller employed for the same hybrid scheme with the proposed controller. The results clearly bring out suppleness of the proposed scheme.

Keywords: Power Quality, Renewable energy resources (RES), Proportional Integral Control, MATLAB/Simulink

Date of Submission: 01-08-2017

Date of acceptance: 14-08-2017

I. INTRODUCTION

In recent years there has been a growing interest in moving away from large centralized power generation towards distributed energy resources. Hybrid solar and wind energy generation presents several benefits for use as a distributed energy resource, especially as a peaking power source. In earlier days, one of the drawbacks in the solar energy sources is the need for energy storage for the system to be utilized for a significant percentage of the day. One way to overcome this disadvantages by utilizing the inverter and its controller circuits for PV based DG units during the day and night times for improving the reactive power compensation and harmonic elimination on its neighboring DG units and the grid by proper exchange of reactive power between the sources.

For this approach the existing developed linear controllers, proportional-integral controller (PI) and predictive control methods are more dominant in current error compensation[1]. But the conventional type PI controllers normally do not have appropriate compensation from the inverters for the grid connected applications. The existing predictive control algorithms are based on deadbeat control in support of voltage source inverters for both power and voltage control, however this method is quite complicated and some digital predictive control strategies suffers from control delay and mainly controllers uses the dc link voltage as one of the control parameter but this method is not superior for PV based DG units without dc-dc converters. This has been eliminated in SVPWM based PI control. But this controller is insensitive to system

parameters since the algorithm does not include the system model. The current and DC voltage regulators are used to transfer the PV power and synchronize the output inverter with grid this however results in power imbalance between the generated power and the load power due to grid impedance variation and can damage the capacitor and protective devices. A virtual inductor is included at the inverter output for real and reactive power decoupling and reactive power control with voltage droop characteristic as in. The online slope estimation algorithm will introduce time lag on dynamic variations[2],[3].

II. BLOCK SCHEMATIC OF THE PROPOSED HYBRID SCHEME

The proposed model consists of a two different Distributed generating units (DG) comprises of PV array and wind power resource

integrated to the grid through VSI and filter and control blocks as indicated in Fig. 1. the consumer loads are connected at PCC. The control block consists of abc - dq0 conversion block and voltage, current and power control blocks. Measuring instruments (voltage and current transformers are connected at the point of common coupling) to measure the currents flow through the VSI, induction generator, grid, customer demand. The 11.5Kw of PV array unit is integrated with grid through the VSI. A 2.5Kw of wind driven induction generator is connected to the grid at the point of common coupling. This two units are supply's the local load and the surplus power is injected to the grid simultaneously PV sourced VSI is used for reactive compensation at PCC for avoid the voltage swell and sag. In order for communication between measured units and DG control units through DSC, embedded kit is used[4],[5].

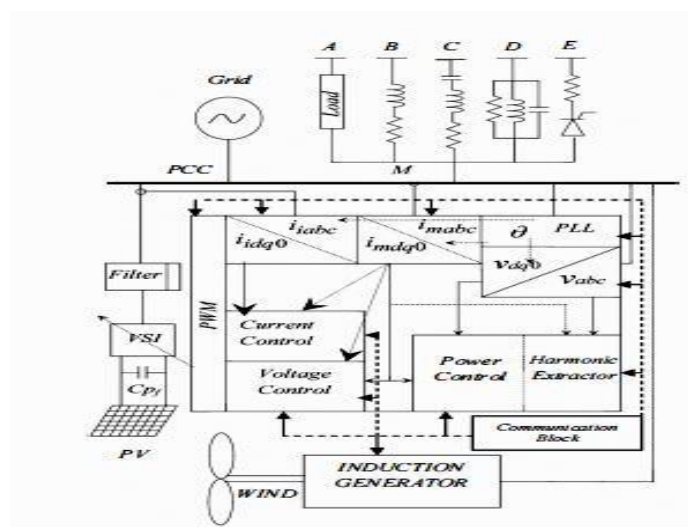

Fig 1 Functional Block Diagram of Proposed Model

III. MODELING OF 3φ SELF EXCITED INDUCTION GENERATOR

The d-q axes equivalent circuits of an induction generator (IG) in synchronously rotating reference

frame are shown in Fig. 2. The complete dynamic equations of IG, taking saturation into account, in synchronously rotating reference frame[6].

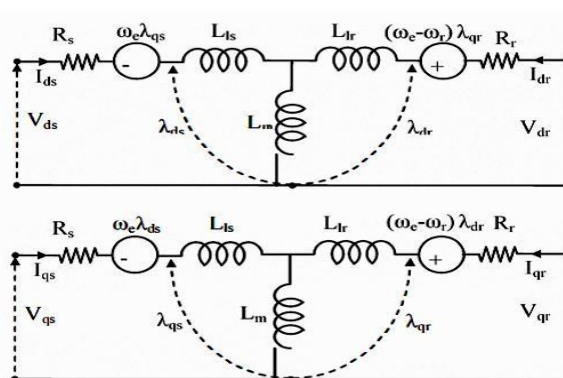

Fig.2-Equivalent circuit of IG - d-q model (a) d-axis

(b) q-axis

These are represented in matrix form as follows

$$\frac{d}{dt} \begin{bmatrix} \lambda_{ds} \\ \lambda_{qs} \end{bmatrix} = \begin{bmatrix} V_{ds} \\ V_{qs} \end{bmatrix} - R_s \begin{bmatrix} i_{ds} \\ i_{qs} \end{bmatrix} - \omega \begin{bmatrix} 0 & -1 \\ 1 & 0 \end{bmatrix} \begin{bmatrix} \lambda_{ds} \\ \lambda_{qs} \end{bmatrix}$$

$$\frac{d}{dt} \begin{bmatrix} \lambda_{dr} \\ \lambda_{qr} \end{bmatrix} = \begin{bmatrix} V_{dr} \\ V_{qr} \end{bmatrix} - R_r \begin{bmatrix} i_{ds} \\ i_{qs} \end{bmatrix} - (\omega - \omega_r) \begin{bmatrix} 0 & -1 \\ 1 & 0 \end{bmatrix} \begin{bmatrix} \lambda_{dr} \\ \lambda_{qr} \end{bmatrix}$$

Where,

R_s = Per-phase stator resistance

R_r = Per-phase rotor resistance referred to stator

i_{qs} = Stator q-axis current, i_{ds} = Stator d-axis

current i_{qr} = Rotor q-axis current, i_{dr} = Rotor d-axis

current V_{qs} = Stator q-axis voltage, V_{ds} = Stator d-

axis voltage V_{qr} = Rotor q-axis voltage, V_{dr} = Rotor

d-axis voltage ω_e = Arbitrary reference frame speed

ω_r = Rotor speed in rad/sec

λ_{qs} = Flux linkages of stator in q -axis λ_{ds} = Flux

linkages of stator in d- axis λ_{qr} = Flux linkages of

rotor in q-axis λ_{dr} = Flux linkages of rotor in d-axis

L_s = Stator Leakage reactance

L_r = Rotor Leakage reactance

L_m = Magnetizing inductance of inductance generator

The injected active and reactive power components,

p and q , can be represented in terms of the d- and q-

axis component of the supply voltage at the PCC

and the injected currents as follows

$$p_{inv} = \frac{3}{2}(v_{id}i_{id} + v_{iq}i_{iq}) \quad q_{inv} = \frac{3}{2}(v_{iq}i_{id} - v_{id}i_{iq})$$

The voltage and current reference values are obtained through general power equation (6). However with this conventional control the dynamic response is poor as the variation of filter capacitance & grid impedance occurring due to change in load cannot meet satisfactorily [7].

$$\begin{bmatrix} i_{id}^* \\ i_{iq}^* \end{bmatrix} = \frac{1}{\|v_i^*\|} \begin{bmatrix} v_{id}^* & -v_{iq}^* \\ v_{iq}^* & v_{id}^* \end{bmatrix} \begin{bmatrix} p_i \\ q_i \end{bmatrix}$$

To compensate for this filter-capacitor current component and the inductor current references are calculated by adding a simple feed-forward compensation term as follows in this proposed model.

$$\begin{bmatrix} i_{id} \\ i_{iq} \end{bmatrix} = \frac{1}{\|v_i\|} \begin{bmatrix} v_{id} & -v_{iq} \\ v_{iq} & v_{id} \end{bmatrix} \begin{bmatrix} p_i \\ q_i \end{bmatrix} + \frac{1}{Z} \begin{bmatrix} v_{id} \\ v_{iq} \end{bmatrix}$$

Where Z is the equivalent impedance of filter capacitance and grid impedance. Incorporating this change in the proposed model helps in achieving a good dynamic response than the existing schemes

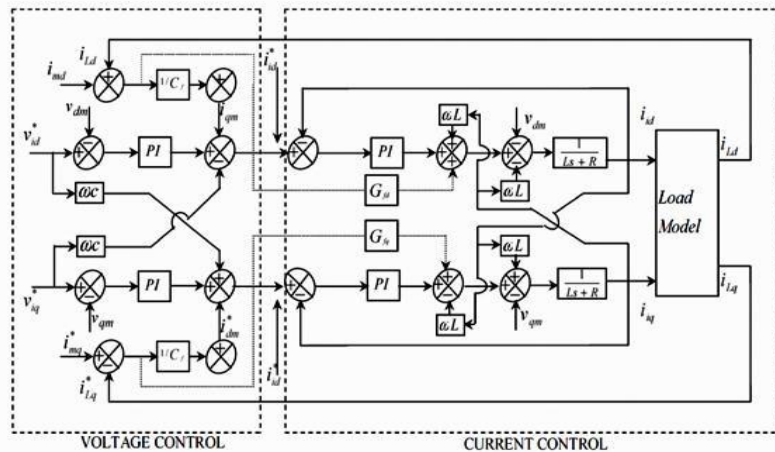

Fig3. Voltage control current control

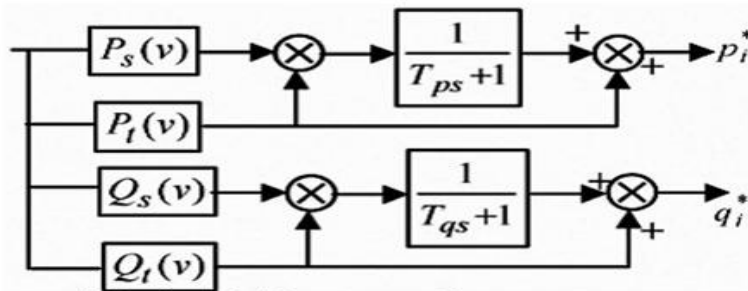

Fig. 4. Dynamic load model for power references

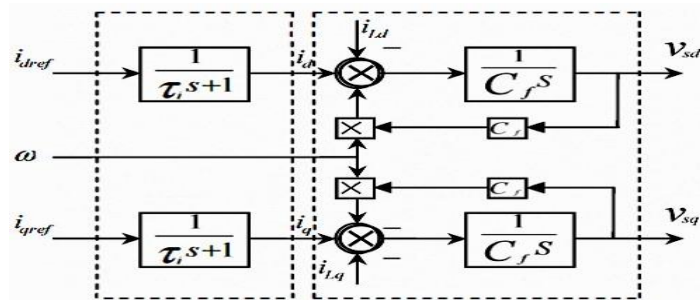

Fig. 5. Block diagram of dynamic load model with inverter model

IV. CONTROLLER FUNCTION

Fast load voltage regulation is a necessary requirement in a power distribution system particularly in feeders serving voltage-sensitive loads and Distributed Generating units with renewable energy source. One of the main objectives of the voltage controller is to achieve fast and accurate generation of the reactive current reference for regulating the voltage at PCC. To achieve this objective, the principle of voltage sag and swell mitigations along with harmonic reduction of DG sourced voltage source inverters are to inject a current into the PCC in order to keep the load voltage at its rated value. Using the voltage-oriented control, the active and reactive power injection can be controlled via a current-controlled VSI. To achieve the objective the required control for operation of i) grid- connected mode ii) islanding mode. In the grid connected mode, both DGs are utilized for supplying pre-specified power to minimize the power import from the grid[7],[8].

V. POWER CONTROL LOOP

$$P_s(v) = P_o \left(\frac{v}{v_o} \right)^{\alpha s} \quad Q_s(v) = Q_o \left(\frac{v}{v_o} \right)^{\beta s} \quad \text{---(9)}$$

$$P_t(v) = P_o \left(\frac{v}{v_o} \right)^{\alpha t} \quad Q_t(v) = Q_o \left(\frac{v}{v_o} \right)^{\beta t} \quad \text{---(11)}$$

With this arrangement, the dynamics of the system changes rapidly in the case of instantaneous load varying situations. A flexible control strategy is required to be developed to handle this dynamics. The proposed multilevel controller comprises of power control loop (external level control), voltage control loop (middle level control) and inner or current control loop. Outer loop creates reference for inner loop as indicated in Fig. 6. All blocks make use of control variables that are possible to be locally measured

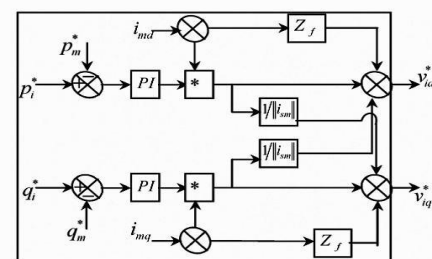

Fig 6. Proposed power control loops.

A. EXTERNAL LEVEL CONTROL

The external level power control is developed is responsible for determining the active and reactive power exchange between the PV system and the utility grid. The proposed external level control scheme is designed for performing simultaneously three major control objectives, one is active power control mode (P-CM) and the voltage control mode (Q-CM) and reduce the harmonic at PCC . In this paper voltage mode control is employed. In this mode, the current reactive power value is measured at point (qm) m this value of qm is compared with qi and error value is fed to the PI control for error minimization and the output of this controller gives dq voltage reference value (Vid *, Viq *J) . These variables are fed to the voltage controller for generation of current reference. The change of reactive power requirement with respect to change of grid impedance value and local loads results in voltage drop across the filter and this drop may affect the system time response and performance. This drawback is nullified in proposed controller by adding Z*ie .

VI. VOLTAGE & CURRENT CONTROL

This voltage control loop is developed This is achieved by varying the modulation of the reactive component of output current and magnitude of the voltage vector at the PCC. The inverter terminal voltage Vi is calculated and the compare to Vi An error signal is produced and then fed to a PI controller. The instantaneous values of the three-phase ac bus voltages in the dq reference frame permits to design a simpler control system than using abc components. The current control loop

developed by following the voltage control loop and this loop controls the real and reactive power independently and good response of the system dynamics and harmonics are ensured due to the inclusion of system modelling and inclusion of instantaneous grid impedance variation due to load variation.

B. OPERATION THEORY OF PROPOSED CONTROLLER

This paper focuses on the control of reactive power form maintaining the rated voltage at PCC. The principles of voltage swell and sag mitigation during the change of local or grid impedance variation is identified by measuring the value of reactive power flow at PCC (qm). This amount of reactive power requirement is compared with the reactive power from the inverter (qi) and the error is used by the controller to balance the present reactive power requirement at PCC for voltage swell and sag. The conventional controllers mostly concentrate on voltage sag and interruption but the proposed controller also compensates the

voltage swell by absorbing the Var during this period real power supplied by the inverter is affected by small value absorbing and reduce the values by extracting the harmonics but the power factor is maintained unity at PCC.

VII. SIMULATION RESULTS

In order to verify the proposed control approach to achieve multi-objectives for grid interfaced DG systems connected to a 3-phase 4-wire network, an extensive simulation study is carried out using MATLAB/Simulink. A 4-leg current controlled voltage source inverter is actively controlled to achieve balanced sinusoidal grid currents at unity power factor (UPF) despite of highly unbalanced nonlinear load at PCC under varying renewable generating conditions. A RES with variable output power is connected on the dc-link of grid-interfacing inverter. An unbalanced 3-phase 4-wire nonlinear load, whose unbalance, harmonics, and reactive power need to be compensated, is connected on PCC.

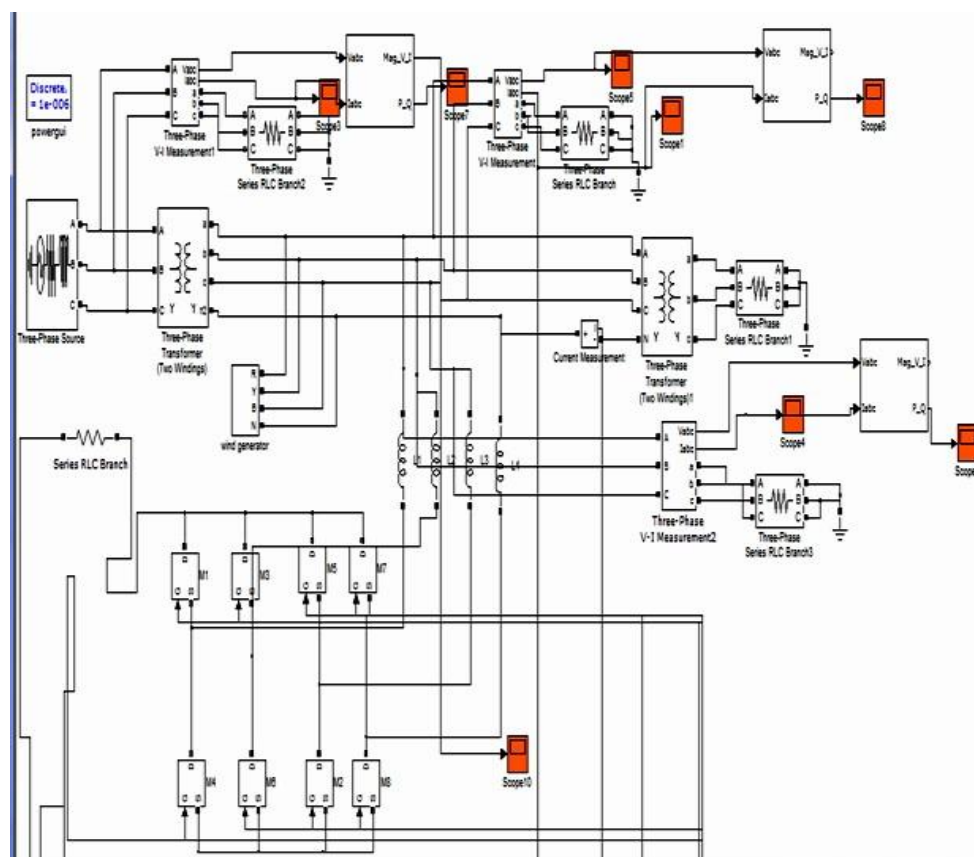

Fig 7 MATLAB Model of base circuit

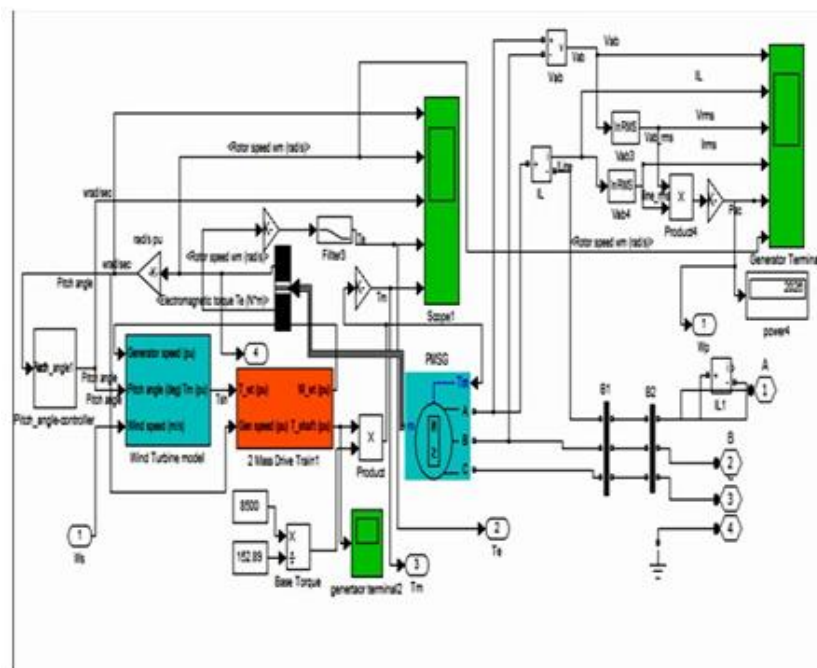

Fig 8 MATLAB Model of Wind generation circuit.

The waveforms of grid voltage, grid currents, unbalanced load current and inverter currents are shown in Fig.9. The corresponding active-reactive powers of grid , load and inverter are shown in fig 10. Positive values of grid active-reactive powers and inverter active-reactive powers imply that these powers flow from grid side towards PCC and from inverter towards PCC, respectively. The active and reactive powers absorbed by the load are denoted by positive signs. Initially, the grid-interfacing inverter is not connected to the network (i.e., the load power demand is totally supplied by the grid alone). Therefore, before time $t=0.72$ s, the grid current profile in Fig is identical to the load current profile of Fig. At $t=0.72$ s, the grid-interfacing inverter is connected to the network. At this instant the inverter starts injecting the current in such a way that the profile of grid current starts changing from unbalanced non linear to balanced sinusoidal current as shown in Fig.9 As the inverter also supplies the Initially, the grid-interfacing inverter is not connected to the network (i.e., the load power demand is totally supplied by the grid alone). Therefore, before time $t=0.72$ s, the grid current profile in Fig. 9 is identical to the load current profile of Fig. At $t=0.72$ s, the grid-interfacing inverter is connected to the network.

At this instant the inverter starts injecting the current in such a way that the profile of grid current starts changing from unbalanced non linear to balanced sinusoidal current as shown in Fig. As the inverter also supplies the load neutral current demand, the grid neutral current becomes zero after $t=0.72$ s. At $t=0.72$ s, the inverter starts injecting

active power generated from RES . Since the generated power is more than the load power demand the additional power is fed back to the grid. The negative sign of , after time 0.72 s suggests that the grid is now receiving power from RES. Moreover, the grid-interfacing inverter also supplies the load reactive power demand locally. Thus, once the inverter is in operation the grid only supplies/receives fundamental active power. At s, the active power from RES is increased to evaluate the performance of system under variable power generation from RES.

This results in increased magnitude of inverter current. As the load power demand is considered as constant, this additional power generated from RES flows towards grid, which can be noticed from the increased magnitude of grid current as indicated by its profile. At s, the power available from RES is reduced. The corresponding change in the inverter and grid currents can be seen from Fig. 10. The active and reactive power flows between the inverter, load and grid during increase and decrease of energy generation from RES can be noticed from Fig.10. The dc-link voltage across the grid- interfacing inverter during different operating condition is maintained at constant level in order to facilitate the active and reactive power flow. Thus from the simulation results, it is evident that the grid-interfacing inverter can be effectively used to compensate the load reactive power, current unbalance and current harmonics in addition to active power injection from RES. This enables the grid to supply/ receive sinusoidal and balanced power at UPF.

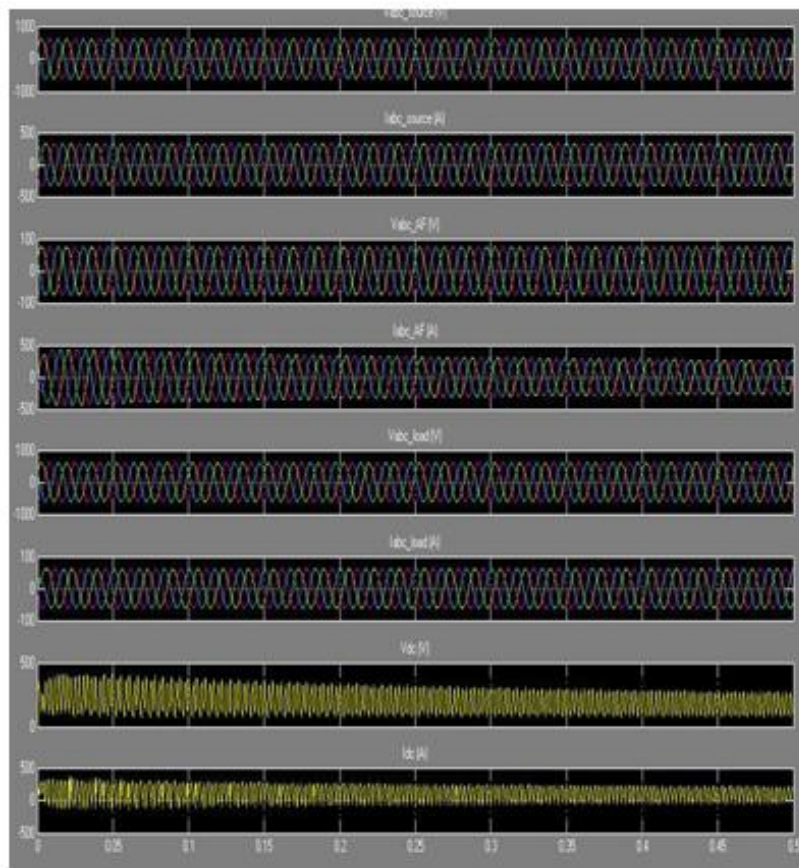

Fig.9 Wave form of voltage and current

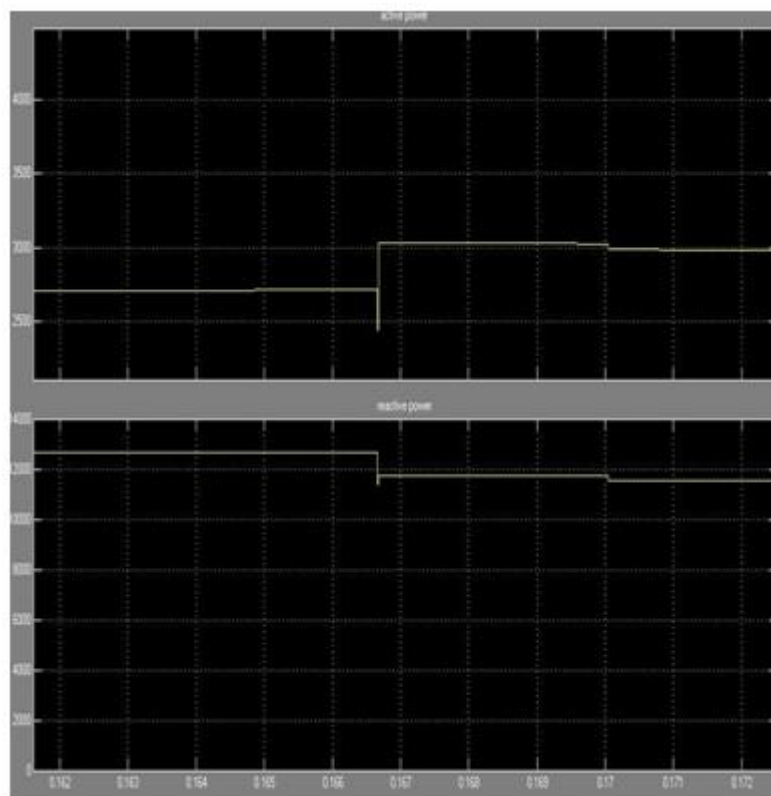

Fig.10 Wave form active-reactive powers of grid.

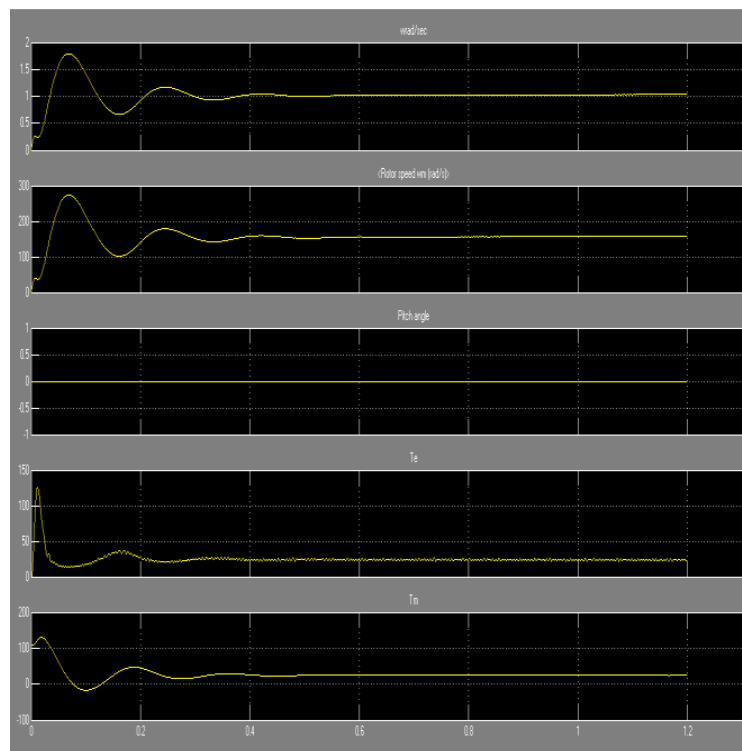

Fig 11. Waveform of inside Wind generation from generation terminal1.

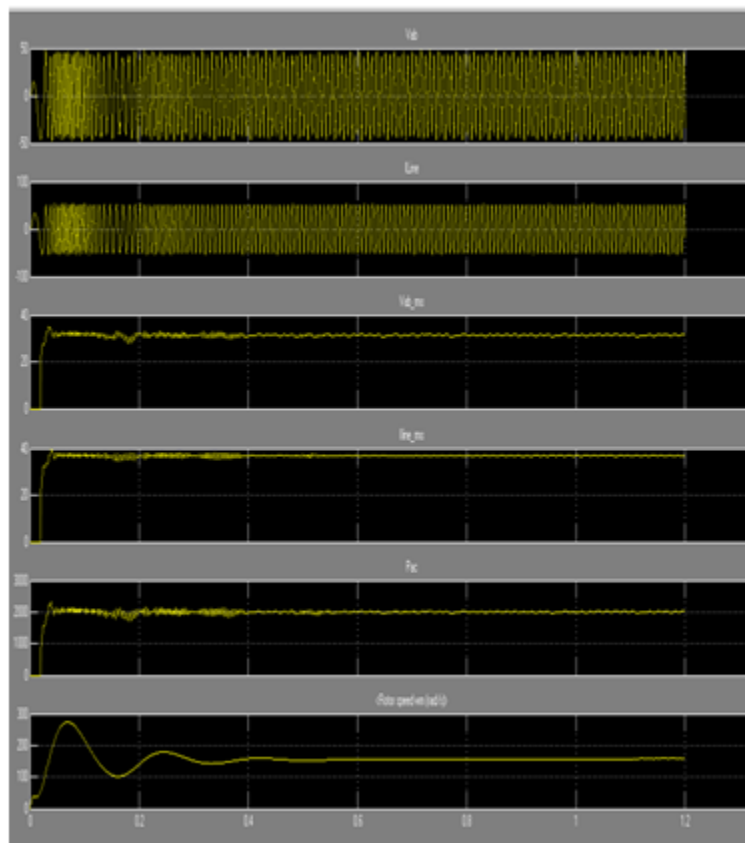

Fig 12 Waveform of inside Wind generation from generation terminal 1.

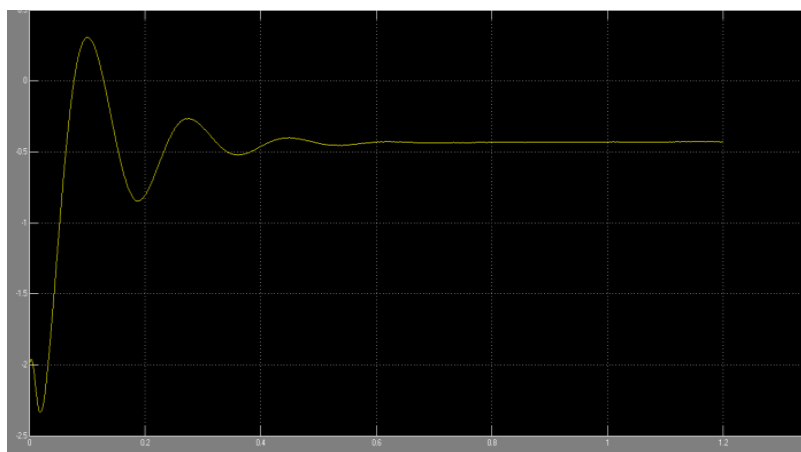

Fig 13 Waveform of inside Wind generation from generation terminal 2

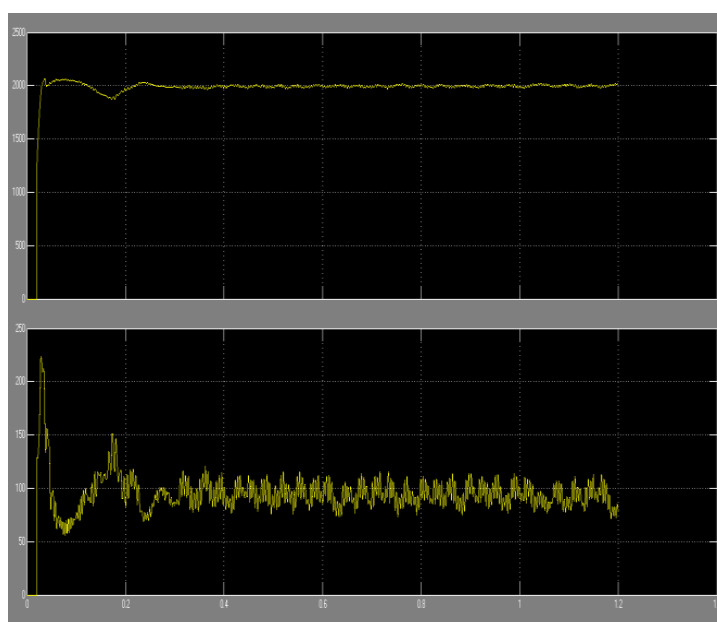

Fig 14 Waveform the real and reactive power Wind generation.

The real and reactive power delivered by the DG source with proposed control during dynamic variation of grid power requirement. The real and reactive power flow between DG source and grid is shown in Fig. 10 give information for sudden change of real and reactive power requirement is compensated by conventional PI controller.

VIII. CONCLUSION

This report presents analysis and improvement of power quality (voltage sag, swell and harmonics) performance of smart grid connected inverter used in distributed generation. The developed controller controls the real and reactive power supplied by the DGs at the PCC. The controller is designed to deliver current at unity power factor at PCC. An increase in reactive power

demand and harmonics at PCC due to change of load and grid impedance variation, would affect the system voltage at PCC. To study the dynamic behaviour of the proposed scheme, the state space model in dq reference frame has been developed for the entire hybrid scheme with the controller for validating the proposed with existing conventional SVPWM PI controller through simulation. The developed controller has been designed with outer power control loop, middle voltage control loop and inner current control loop. The performance of the developed controller model is evaluated through MA TLAB/Simpower platform. Simulation have been carried out and the results are presented for both varying local power demand and grid impedance variation to evaluate the performance the proposed controller.

REFERENCE

- [1]. Bhim Singh, Kamal Al-Haddad, Senior Member, IEEE, and Ambrish Chandra, Member, IEEE. A Review of Active Filters for Power Quality Improvement
- [2]. Chao-Shun Chen, Senior Member, IEEE, Cheng-Ta Tsai, Chia-Hung Lin, Member, IEEE, Wei-Lin Hsieh, and Te-Tien Ku ,2011. Loading Balance of Distribution Feeders With Loop Power Controllers Considering Photovoltaic Generation.
- [3]. Dr. Recayi Pecen, Dr. MD Salim, & Dr. Marc Timmerman. A Hybrid Solar-Wind Power Generation System as an Instructional Resource for Industrial Technology Students. Volume 16, Number 3 - May 2000 to July 2000.
- [4]. Dr. Recayi Pecen, Dr. MD Salim, & Mr. Ayhan Zora . A LabView Based Instrumentation System for a Wind-Solar Hybrid Power Station. Volume 20, Number 3 - June 2004 through August 2004.
- [5]. Jose M. Espi Huerta, Member, IEEE, Jaime Castello-Moreno, Student Member, IEEE, Jonatan Roberto Fischer, and Rafael Garcia-Gil, "A Synchronous Reference Frame Robust Predictive Current Control for Three Phase Grid-Connected Inverters," IEEE Transactions on Industrial Electronics, Vol. 57, NO, 3 MARCH 2010,
- [6]. Lu Fang College of Electrical and Information Engineering Hunan University Changsha, Hunan Province, Chinae-mail:2001xxy@163.com. A Novel Power Quality Compensator for Negative sequence and Harmonic Currents in High-speed Electric Railway.
- [7]. M.Sharanya, B.Basavaraja , M.Sasikala , An Overview of Dynamic Voltage Restorer for Voltage Profile Improvement. International Journal of Engineering and Advanced Technology (IJEAT), December 2012.
- [8]. Manjulata Badi 2012, POWER QUALITY IMPROVEMENT USING PASSIVE
- [9]. SHUNT FILTER, TCR AND TSC COMBINATION .A Thesis Submitted in Partial Fulfillment of the Requirements for the Award of the Degree of Master of Technology in Electrical Engineering (Control & Automation). [9] Marian p, Kazmier kowski, Fellow, IEEE, and Luigi Malesani, Fellow, IEEE, "Current Control Techniques for Three-Phase Voltage-Source PWM Converters: A Survey"IEEE Transactions on Industrial Electronics, Vol. 45, NO. 5, OCTOBER 1998.
- [10]. Nikita Hari , K.Vijayakumar and Subhranshu Sekhar Dash. Department of Electrical & Electronics Engineering, SRM University, Chennai, India-603203 ,2011. A Versatile Control Scheme for UPQC for Power Quality Improvement.
- [11]. N. Hamrouni-, M. Jraidi, A. Che' rif "New control strategy for 2- stage grid-connected photovoltaic power system," Renewable Energy 33,(2008) 2212-2221.



Biographies and Photographs

Mandadi Surender Reddy is a research scholar in department of Electrical Engineering in Sunrise University, Rajasthan, India. He obtained his M.Tech degree JNTU College of Engineering, JNTU Hyderabad, Telangana, India. He completed Graduation in Electrical and Electronics Engineering, JNTU, Hyderabad, Telangana, India. His research area includes FACTS Controllers, Power Quality, Power System and Power Electronics



Ganji Vivekananda is a research scholar in department of Electrical and Electronics Engineering in Acharya Nagarjuna University, Guntur, Andhra Pradesh, India. He obtained his M.Tech degree JNTU College of Engineering, JNTU Hyderabad, Telangana, India. He completed Graduation in Electrical and Electronics Engineering, JNTU, Hyderabad, Telangana, India. His research area includes FACTS Controllers, Power Quality, Power System and Power Electronics.

International Journal of Engineering Research and Applications (IJERA) is **UGC approved** Journal with Sl. No. 4525, Journal no. 47088. Indexed in Cross Ref, Index Copernicus (ICV 80.82), NASA, Ads, Researcher Id Thomson Reuters, DOAJ.

Mandadi Surender Reddy. "Performance Improvement of power system with Power Quality Features Using Hybrid (Solar Wind) Energy." International Journal of Engineering Research and Applications (IJERA), vol. 7, no. 8, 2017, pp. 73–82.