

Effective Removal of Noise using Threshold Shrinkages Techniques in MRI Images

A.Afreen Habiba¹, Dr.B.Raghu²

¹. PhD (Research Scholar), Department of Computer Science, Bharath University, Chennai

². Principal and Prof of Computer Science and Engineering, SVS Group of Institutions, Warangal

ABSTRACT

Image Denoising is a utmost challenge for Researchers. Image Denoising evaluates the image data to create a visual quality image. The original pixel values is mislay when the noise is miened. Noise is the effect of error, the pixel value does not affect the original intensity of the real scene in the image. Exceptionally Medical images are interrupted by a variety of noises depending on their devices through acquisition and transmission. In this work to denoise Gaussian noises and Speckle noises in MRI Images undergo a contourlet domain for decomposition of input images. Contourlet is used to preserve the edges and contours. After decomposition some threshold methods are applied such as Bayes Shrink, Neigh Shrink, and Block Shirnk. These Threshold methods are used to unfasten the noises. Finally analyse the performance of denoised image to find the better result. Performance of Medical Image Denoising is reckoning by Peak Signal to Noise Ratio (PSNR), Structural Similarity Index (SSIM), Image Quality Index (IQI) and Normalized Cross Correlation (NCC)

Keywords: Contourlet, Image Denoising, IQI, PSNR, Threshold.

Date of Submission: 16-12-2017

Date of acceptance: 30-12-2017

I. INTRODUCTION

Image Denoising is one of the rudimentary step in digital image processing and its plays an ineluctable task in image processing and computer vision application. Denoising affects the image quality with some artifacts. The main focus of an image denosing is to accomplish noise reduction and maintain the quality. The Frequent application of Imaging devices to Medical analysis, visual tracking and Image classification.

Medical images are received from medical devices such as X-Ray, Computed Tomography (CT), Positron Emission Tomography (PET), Single Positron Emission Tomography (SPET) and Magnetic Resonance Image (MRI). MRI uses magnetic fields and radio waves to manifest the images of organs, soft tissues and bones. MRI are non-invasive and painless. It can help to detect a diseases and guiding for treatment for spacious range of condition. In some types of analysis it can furnish a similar information to CT. Medical images contain some level of noises due to the corruption through capture and store them.

Noises means unwanted signals. Depending on the devices noise may be additive and multiplicative noises. Additive noises are Gaussian and Salt and Pepper noise and Multiplicative noises are Speckle noise and Rician noises. But Medical images are almost corrupted with Multiplicative noise. MRI images are corrupted with Rician and Gaussian noise Mixture. Contourlet Transform is

Multiscale and Multidimensional image representation method. Contourlet Transform is fabricate by Laplacian pyramid and Directional Filter Bank. Contourlet conserve the edges and shape of the boundary. Thresholding is one of the technique in the image processing such as Bayes Shrink, Visu Shrink, Neigh Shrink, Sure Shrink, Neighsure Shrink, Normal Shrink, Block Shrink, Min-Max Shrink and Bivariate Shrink and Smooth shrink, Normal shrink. These methods are to make a noises free in an image

A. Related Works

Image denoising is one of the classical problems in digital image processing, and has been studied for nearly half a century due to its important role as a pre-processing step in various electronic imaging applications. Its main aim is to recover the best estimate of the original image from its noisy versions [8]. Medical images are typically corrupted with noise, which hinder the medical diagnosis based on these images. There has been substantial interest in the problem of denoising of images in general. Tools from traditional image processing field have been applied to denoised MR images [23]. However, the process of noise suppression must not appreciably degrade the useful features in an image.

Noise is present in an image either in an additive or multiplicative form. An additive noise follows the rule $w(x, y) = s(x, y) + n(x, y)$, While the multiplicative noise satisfies $w(x, y) = s(x, y) \times n(x, y)$

,Where $s(x,y)$ is the original signal, $n(x,y)$ denotes the noise introduced into the signal to produce the corrupted image $w(x,y)$, and (x,y) represents the pixel location. The above image algebra is done at pixel level. Image addition also finds applications in image morphing [16].By image multiplication, we mean the brightness of the image is varied.The classification of noise relies mainly on the characterizing probabilistic specifications. There are the four types of noise categories in image processing [27].The Gaussian noise can be modelled in terms of amplifier noise, which is additive Gaussian, and hence independent at each pixel and intensity of the signal. This noise follows probability distribution function and is most frequently occurring in digital images [4].Mean gray level is increased in speckle noise from local area of an image. Image interpretation and recognition is very difficult in this type of noise. Mean and Variance of local area and single pixel are proportional to each other values. Speckle is also known as or type of granular noise[2].

Contourlet transforms is by introducing basis functions which are local,directional, and with multiresolution expansion.This representation has two basic building blocks, the Laplacian pyramid (LP) and the Directional Filter Bank (DFB).A computationally efficient iterative double filter bank structure proposed in [11,12] uses Laplacian pyramid [25] to capture the point discontinuities, followed by a directional _filter bank [21] to connect point discontinuities into linear structures. contourlet Transform achieves perfect reconstruction if the LP and DFB use perfect reconstruction filters with redundancy ratio of 4/3 [12]. Contourlet frames are compactly supported with flexible anisotropy.

The threshold method, developed by Donoho [18] in 1995, provides a viable treatment option for the wavelet coefficients of nonlinear processing and, consequently, significantly advanced the field of image denoising. Bayes shrink was proposed by Chang, Yu and Vetterli [14]. The objective of this technique is to minimize the Bayesian risk, and therefore named as BayesShrink. It uses soft thresholding and is subband-dependent, which meant that thresholding in the wavelet decomposition is done at each subband of resolution. This shrinkage technique includes the use of neighboring coefficients. The window sizes used for the neighborhood window could vary being 3X3, 5X5, 7X7, 9X9, etc. amongst them 3X3 serves the best[15]. the threshold value calculated using universal shrinkage technique but since this does not provide an optimal output. Block Shrink is a completely data-driven block thresholding approach and is also easy to implement [9]. It can decide the optimal block size and threshold for every wavelet sub band by minimizing Stein's unbiased risk estimate (SURE).

B. Motivation And Justification

Image Denoising is the efficient one to denoise the images as well as to prevents the edges also. Contourlet is the one of the best method for preserving the edges. The Contourlet can decompose the images with any degree of directionality including all the curves and the countover. Contourlet clearly identifies the curves and edges. Contourlet is very adpable for both natural images and medical images for traps the geometrical structures. Contourlet has better performance than wavelets because Contourlet can represent the lines,curves,edges and contours. Contourlet is too appropriate for multi-scale edge in image enhancement. Contourlet Transform can procure higher Peak Signal to Noise Ratio(PSNR). Contourlet gives more accurate result for geometrical structures. It can cherish the strong edges and enhanced the weak edges. During these advantages So I modivate to do work in Contourlet domain.

C. Organisation Of The Paper

The rest of the paper is organized as follows. Methodology includes the outline of the proposed work, Contourlet transform, Thresholding techniques are presented in Section II. Experimental results are shown in Section III. Performance evaluation are discussed in Section IV and Finally Conclusion is shown in Section V

II. METHODOLOGY

A. Outline of the Proposed Method

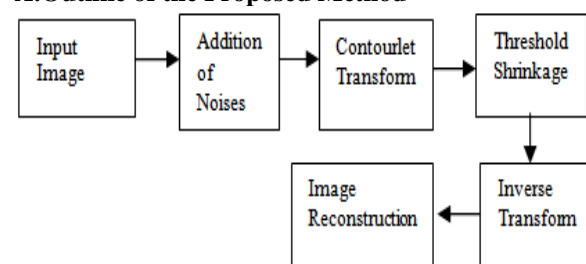

Fig.1 Block Diagram for Contourlet Transform

Fig.1 shows the block diagram for Contourlet Transform. Using Contourlet Transform it can decompose the image and it can get the decomposed coefficients then apply the shrinkage methods. Threshold shrinkage methods denoise these coefficients and then apply the inverse transform to get the denoised image. Using Performance Metrics to find the better thresholding Shrinkage Methods.

B. The Contourlet Transform

The Contourlet Transform (CT) is a directional multiresolution image representation scheme proposed by Do and Vetterli, which is effective in representing smooth contours in different

directions of an image, thus providing directionality and anisotropy [12]. The framework of the contourlet transform in (Fig.2)The method utilizes a double filter bank (Fig.3) in which, first the Laplacian Pyramid (LP) [25] detects the point discontinuities of the image and then the Directional Filter Bank (DFB) [21] links point discontinuities into linear structures. The LP provides the means to obtain multiscale decomposition. In each decomposition level it creates a downsampled lowpass version of the original image and a more detailed image with the supplementary high frequencies containing the point discontinuities. This scheme can be iterated continuously in the lowpass image and is restricted only by the size of the original image due to the downsampling. The DFB is a 2D directional filter bank that can achieve perfect reconstruction. The simplified DFB used for the contourlet transform consists of two stages, leading to $2l$ subbands with wedge-shaped frequency partitioning [20]. The first stage is a two-channel quincunx filter bank [8] with fan filters that divides the 2D spectrum into vertical and horizontal directions. The second stage is a shearing operator that just reorders the samples. By adding a shearing operator and its inverse before and after a two-channel filter bank, a different directional frequency partition is obtained (diagonal directions), while maintaining the ability to perfectly reconstruct the original image.

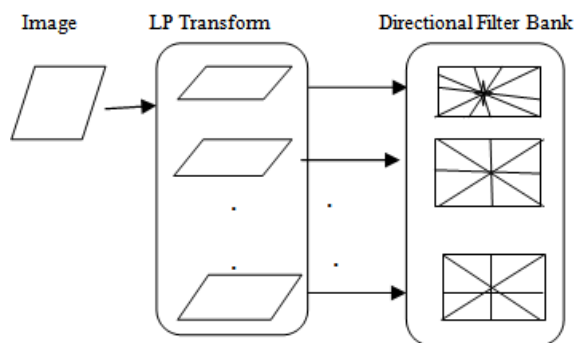

Fig.2 The Contourlet Transform Framework.

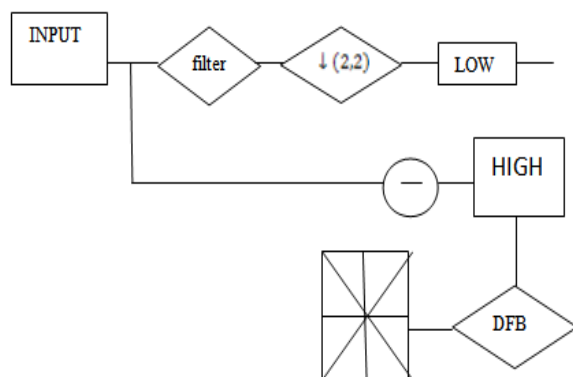

Fig. 3 The Contourlet Filter Bank.

By combining the LP and the DFB, a double filter bank named Pyramidal Directional Filter Bank (PDFB) is obtained. Bandpass images from the LP decomposition are fed into a DFB in order to capture the directional information. This scheme can be repeated on the coarser image levels, restricted only by the size of the original image. The combined result is the contourlet filter bank. The contourlet coefficients have a similarity with wavelet coefficients since most of them are almost zero and only few of them, located near the edge of the objects, have large magnitudes [10]. In this work, the Cohen and Daubechies 9-7 filters [22] have been utilized for the Laplacian Pyramid. For the Directional Filter Bank, these filters are mapped into their corresponding 2D filters using the McClellan transform as proposed by Do and Vetterli in [12]. The creation of optimal filters for the contourlet filter bank remains an open research topic.

C. Thresholding Techniques

Thresholding is a technique used for signal and image de-noising. The shrinkage rule defines how we apply the threshold [26]. [5] It is clearly proved that highest PSNR value is achieved at lowest standard deviation and lowest PSNR at highest Standard Deviation. Most of the real time and online applications require these types of filters with less execution time.

1)Block Shrink

Block Shrink is a completely data-driven block thresholding approach and is also easy to implement [9]. It can decide the optimal block size and threshold for every subband by minimizing Stein's unbiased risk estimate (SURE). The block thresholding simultaneously keeps or kills all the coefficients in groups rather than individually, enjoys a number of advantages over the conventional term-by-term thresholding. The block thresholding increases the estimation precision by utilizing the information about the neighbor wavelet coefficients. The local block thresholding methods all have the fixed block size and threshold and same thresholding rule is applied to all resolution levels regardless of the distribution of the coefficients. [9]. For every subband, we need to divide it into a lot of square blocks. Block Shrink can select the optimal block size and threshold for the given subband by minimizing Stein's unbiased risk estimate.

2)Bayes Shrink

Bayes Shrink is a sub band adaptive data driven thresholding method. This method assumes that the coefficients are distributed as a generalized Gaussian distribution in each sub . Bayes Shrink was proposed by Chang, Yu and Vetterli. The goal of this method is to minimize the Bayesian risk, and hence

its name, Bayes Shrink [14]. The Bayes threshold is defined as

$$\lambda = \frac{\sigma_{noise}^2}{\sqrt{\max(\sigma_s^2 - \sigma_{noise}^2, 0)}} \quad (1)$$

This method defines the rules for applying the threshold to the coefficients. The threshold is compared to all coefficients of the contourlet domain and when the coefficients are less than the threshold value they are assigned zero values, otherwise they are kept unaltered.

The reason behind it is that small coefficients are supposed to be not of signal elements and so can be modified to zeroes. The large coefficients are supposed to be of important signal features band. It also finds a threshold which minimizes the Bayesian risk. σ^2 is the noise variance and σ is the signal variance

3) Neigh Shrink

The method NeighShrink thresholds the coefficients according to the magnitude of the squared sum of all the coefficients, i.e., the local energy, within the neighborhood window [1]. The neighborhood window size may be 3x3, 5x5, 7x7, 9x9, etc. But, the authors have already demonstrated through the results that the 3x3 window is the best among all window sizes. The neighboring window of size 3*3 centered at the coefficient to be shrunk. The shrinkage function for NeighShrink of any arbitrary 3x3 window centered at (i,j) is expressed as:

$$T_{ij} = 1 - \frac{T_u^2}{S_{ij}^2} \quad (2)$$

where, T_u is the **universal threshold** and S_{ij}^2 is the squared sum of all wavelet coefficients in the respective 3x3 window given by:

$$S_{ij}^2 = \sum_{n=j-1}^{j+1} \sum_{m=i-1}^{i+1} Y_{m,n}^2 \quad (3)$$

D.Noise Models

1) Gaussian Noise or Amplifier Noise

This noise has a probability density function [pdf] of the normal distribution. It is also known as Gaussian distribution. It is a major part of the read noise of an image sensor that is of the constant level of noise in the dark areas of the image. [3]

$$p(z) = \frac{1}{\sqrt{2\pi}\sigma} e^{-\frac{(z-\mu)^2}{2\sigma^2}} \quad (4)$$

2) Speckle noise

A different type of noise in the coherent imaging of objects is called speckle noise. This noise is, in fact, caused by errors in data transmission [17, 19]. This kind of noise affects the ultrasound images [19]. Speckle noise follows a gamma distribution and is given as

$$F(g) = \frac{g^{\alpha-1}}{(\alpha-1)! \alpha^\alpha} e^{-\frac{g}{\alpha}} \quad (5)$$

where, α^α is the variance, α is the shape parameter of gamma distribution and g is the gray level.

III. EXPERIMENTAL RESULTS

Experiments are analysed in the MRI slicing Image shown in Fig.4. Gaussian noises and Speckle noises are used. Denoised image is shown in Fig.5. Shrinkage Methods are used to denoise the images. In that results it identifies the better one. Bayes Shrink and Block Shrink is performed well. Then analyse the results with various variance that is shown in Fig.6

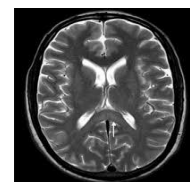

Fig.4 Original Image

Noise type	Noisy image	Bayes Shrink	Neigh Shrink	Block Shrink
Gaussian				
Speckle				

Fig 5 Noise vs Threshold

Noise Variance	Gaussian Noise	Speckle Noise
	Bayes Shrink	Block Shrink
Noisy image		
0.02		
0.04		
0.06		
0.08		

Fig.6 Noise Level vs Threshold

IV.PERFORMANCE ANALYSIS

A.Performance Metrics

1)Peak Signal to Noise Ratio (PSNR)

It is the ratio between maximum possible power of a signal and the power of corrupting noise that affects the quality and reliability of its representation.PSNR is calculated as

$$PSNR = 10\log_{10}\left(\frac{MAX^2}{MSE}\right) \quad (6)$$

Where MSE is mean square error and MAX is the maximum pixel value of image [6].

2)Structural Similarity Index (SSIM)

It is a method for measuring the similarity between two images. The SSIM measure the image quality based on an initial distortion-free image as reference.

$$SSIM = \frac{(2\mu_x \mu_y + C_1)(2\sigma_{xy} + C_2)}{(\mu_x^2 + \mu_y^2 + C_1)(\sigma_x^2 + \sigma_y^2 + C_2)} \quad (7)$$

μ_x the average of x;

μ_y the average of y;

σ_x^2 the variance of x;

σ_y^2 the variance of y;

σ_{xy} the covariance of x and y;

$C_1 = (k1L)^2$ and $C_2 = (k2L)^2$

are two variables to stabilize the division with weak denominator. L the dynamic range of the pixel-values $k1 = 0.01$ and $k2 = 0.03$ by default. The resultant SSIM index is a decimal value between -1 and 1, and value 1 is only reachable in the case of two identical sets of data.[7]

3)Normalized Correlation (NC)

Normalized correlation is calculated by

$$NK = \frac{\sum_{i=1}^M \sum_{j=1}^N (g(i,j) \cdot g'(i,j))}{\sqrt{\sum_{i=1}^M \sum_{j=1}^N (g(i,j))^2}} \quad (8)$$

If the normalized cross correlation tends to 1, then the image quality is deemed to be better.[2]

4)Image Quality Index(IQI)

The Image Quality Index (IQI), Q , is proposed by Wang and Bovik [22] as a product of three different factors: loss of correlation, luminance distortion, and contrast distortion and is defined as

$$Q = \frac{\sigma_{fg}}{\sigma_f \sigma_g} \cdot \frac{2f \cdot g}{f^2 + g^2} \cdot \frac{2\sigma_f \sigma_g}{\sigma_f^2 + \sigma_g^2} \quad (9)$$

The first component of eqn. (10) is the correlation coefficient between f and g , which measures the degree of linear correlation between f and g and its dynamic range is [-1,1]. The second component, with a value range of [0,1], measures how close the mean luminance is between f and g . σ_f and σ_g can be viewed as estimate of the contrast of f and g , so the third component with a value range of [0,1] measures how similar the contrasts of the images are.Thus, Q can be rewritten as

$$Q = \frac{4\sigma_f \sigma_g f \cdot g}{(\sigma_f^2 + \sigma_g^2)(f^2 + g^2)} \quad (10)$$

B.Performance Evaluation of various thresholding techniques

Experimental results are examine by using the Performance metrics.In Table I PSNR and IQI metrics are compared with different shrinkage methods.In Table I bayes,neigh and block shrink are tested and their results are shown

Table I Threshold Type vs Metric

Metric	Gaussian Noise			Speckle Noise		
	Threshold Type					
	Neigh	Block	Bayes	Neigh	Block	Bayes
PSNR	20.7937	20.7869	20.8135	29.8988	29.9926	29.9029
IQI	0.44189	0.44237	0.44411	0.72281	0.78185	0.78208

Table II Noise level vs Metric

Metric	Noise Variance	Bayes Shrink	Block Shrink
PSNR	0.02	20.4696	26.9613
	0.04	19.8316	24.0188
	0.06	19.0050	22.3216
	0.08	18.0501	21.1891
IQI	0.02	0.44007	0.66773
	0.04	0.43454	0.65762
	0.06	0.42779	0.61101
	0.08	0.41727	0.57612

Table III Noise Level vs other Metrics

Metric	Noise Variance	Gaussian	Speckle
		Bayes Shrink	Block Shrink
PSNR	0.02	20.4696	26.9613
	0.04	19.8316	24.0188
	0.06	19.0050	22.3216
	0.08	18.0501	21.1891
IQI	0.02	0.44007	0.66773
	0.04	0.43454	0.65762
	0.06	0.42779	0.61101
	0.08	0.41727	0.57612
SSIM	0.02	0.40369	0.82068
	0.04	0.39707	0.74437
	0.06	0.38919	0.69107
	0.08	0.37865	0.65322
NCC	0.02	1.03910	0.98772
	0.04	1.03800	0.98725
	0.06	1.11860	0.98293
	0.08	1.16210	0.97639

In Table II noise levels are varied and their results are presented. In Table I and Table II analysis it identifies the best threshold for a specific noises and the various noise variance are applied to the best shrinkage. Image quality is improved for different noise levels. In Table III it prefer some extra metrics also and use the different noise variance to predict the extract results. Bayes and Block shrinkage are performed well and their present result are very much better.

V. CONCLUSION

This paper presents, image denoising scheme based on Contourlet transform. Image qualitative are measured by PSNR, SSIM, NCC, IQI. Higher PSNR value has a good quality image. We have observed the experimental results with three shrinkages such as Bayes, Neigh and Block shrink. Using experimental results, the better shrinkage methods is described. Contourlet domain based denoising works well for Bayes and Block Shrink. Bayes Shrink is performed well in Gaussian noises and Block Shrink is also better suited for the speckle noise as compared to other threshold. Visual appearance is also enhanced after denoising.

REFERENCES

- [1]. M. Neelima¹, Md. Mahaboob Pasha² "Wavelet Transform Based On Image Denoising Using Thresholding Techniques" *International Journal of Advanced Research in Computer and Communication Engineering* Vol. 3, Issue 9, September 2014
- [2]. S.P. Chokkalingam, K. Komathy, M. Vinoth And R. Saravanan "Performance Analysis Of Bone Images Using Various Edge Detection Algorithms And Denoising Filters" *International Journal of Pharma and Bio Sciences* April 5 2014
- [3]. Priyanka Kamboj¹ and Versha Rani² "A BRIEF STUDY OF VARIOUS NOISE MODEL AND FILTERING TECHNIQUES" in *Journal of Global Research in Computer Science* Volume 4, No. 4, April 2013
- [4]. *International Journal of Computer Applications* (0975 – 8887) Volume 51– No.5, August 2012, "Efficient noise removing based optimized smart dynamic Gaussian filter, By: Hassen Seddik and Ezzedine Ben Braiek
- [5]. Rajesh Kumar Rai, Jyoti Asnani, R.R. Sontakke, "Review on Shrinkage Techniques for Image Denoising", *International Journal of Computer Applications*, Vol. 42, Issue No.19, pp. 13-16, March 2012.
- [6]. Olawuyi, N.J. "Comparative Analysis of Wavelet Based Denoising Algorithms on Cardiac Magnetic Resonance Images" *Afr J Comp & ICT Olawuyi et al - Comparative Analysis of Wavelet-Based Denoising Algorithm* Vol 4. No. 1. June 2011
- [7]. Mehul P. Sampat, Member, IEEE, Zhou Wang, Member, IEEE, Shalini Gupta, Alan Conrad Bovik, Fellow, IEEE, and Mia K. Markey, Senior Member, IEEE, (2009), *Complex Wavelet Structural Similarity: A New Image Similarity Index*, *IEEE transactions on image processing*, vol. 18. Page no 2385-2401
- [8]. D. Ghandurai and V. Sadasivam, "an effective adaptive thresholding technique for wavelet based image denoising." *World academy of science, engg. & technology*, 2008.
- [9]. Zhou Dengwen and Shen Xiaoliu, "Image Denoising Using Block Thresholding," *IEEE Congress on Image and Signal Processing*, pp. 335-338, 2008. doi: 10.1109/CISP.2008.131.
- [10]. Yifan, Z. and Liangzheng, X., "Contourlet-based feature extraction on texture images," *Proc. International Conference on Computer Science and Software Engineering*, 221-224 (2008).
- [11]. D.-Y. Po and M. N. Do, "Directional multiscale modeling of images using the contourlet transform," *IEEE Transactions on Image Processing*, vol. 15, no. 6, pp. 1610-1620, 2006.
- [12]. Do, M. N. and Vetterli, M., "The contourlet transform: an efficient directional multiresolution image representation," *IEEE Transactions on Image Processing* 14(12), 2091-2106 (2005).
- [13]. Zhou Wang, Alan C. Bovik, "A Universal Image Quality Index", *IEEE Signal Processing Letters*, 9(3), 2002
- [14]. S. G. Chang, B. Yu and M. Vetterli, "Adaptive wavelet thresholding for image denoising and compression," *Image Processing, IEEE Transactions on*, vol. 9, no. 9, pp. 1532-1546, 2000.
- [15]. Mallat, S. A wavelet tour of signal processing. second addition Academic press 1999
- [16]. Scott E Umbaugh, *Computer Vision and Image Processing*, Prentice Hall PTR, New Jersey, 1998.
- [17]. L. Gagnon and F.D. Smaili "Speckle Noise Reduction of Airborne SAR Images with Symmetric Daubechies Wavelets" *SPIE Proc.* **2759**, 1424 (1996)
- [18]. D. L. Donoho, "De-noising by soft-thresholding," *IEEE Transactions on Information Theory*, vol. 41, no. 3, pp. 613-627, 1995.
- [19]. H. Guo, J E Odegard, M. Lang, R.A. Gopinath, I.W. Selesnick, and C.S. Burrus "Wavelet based Speckle reduction with application to SAR

- based ATD/R First Int. Conf. on image processing, **1**, 75 (1994).
- [20]. Shapiro, J. M., "Embedded image coding using zerotrees of wavelet coefficients," *IEEE Transactions on Signal Processing* 41(12), 3445-3462 (1993).
- [21]. Bamberger, R. H. and Smith, M. J. T., "A filter bank for the directional decomposition of images: Theory and design," *IEEE Transactions on Signal Processing* 40(4), 882-893 (1992).
- [22]. Cohen, A., Daubechies, I. and Feauveau, J. C., "Biorthogonal bases of compactly supported wavelets," *Communications on Pure and Applied Mathematics* 45(5), 485-560 (1992).
- [23]. D. J. Peck H. S. Zadeh, J. P. Windham and A. E. Yagle, "A comparative analysis of several transformations for enhancement and segmentation of magnetic resonance image scene sequences," *IEEETrans. Med.Imaging*, vol. 11, no. 3, pp. 302-318, September 1992
- [24]. Vetterli, M., "Multidimensional subband coding: Some theory and algorithms," *Signal Processing* 6(2), 97-112 (1984).
- [25]. Burt, P. J. and Adelson, E. H., "The Laplacian Pyramid as a compact image code," *IEEE Transactions on Communications* 31(4), 532-540 (1983).
- [26]. Byung-Jun Yoon and P. P. Vaidyanathan, "Wavelet-based denoising by customized thresholding", Work supported in part by the ONRgrant N00014-99-1-1002, USA.
- [27]. *International Journal of Advanced Research in Computer Science and Software Engineering*, "A Comparative Study of Various Types of Image Noise and Efficient Noise Removal Techniques", By: Mr. Rohit Verma and Dr. Jahid Ali.

International Journal of Engineering Research and Applications (IJERA) is **UGC approved** Journal with Sl. No. 4525, Journal no. 47088. Indexed in Cross Ref, Index Copernicus (ICV 80.82), NASA, Ads, Researcher Id Thomson Reuters, DOAJ.

A.Afreen Habiba "Effective Removal of Noise using Threshold Shrinkages Techniques in MRI Images." *International Journal of Engineering Research and Applications (IJERA)* , vol. 7, no. 12, 2017, pp. 36-42.