

Forward and Reverse Motoring of DC Hoist Motor on Container Crane (CC) Operation

Rukmini^{*}, Nadjamuddin Harun^{**}, Sakti Adji Adisasmita^{***}, Ganding Sitepu^{****}

^{*}(Doctoral programs in Civil Engineering, Hasanuddin University & Makassar Merchant Marine Polytechnic)^{**}(Electrical Engineering Department, Hasanuddin University)

^{***}(Civil Engineering Department, Hasanuddin University)

^{****}(Naval Engineering Department, Hasanuddin University)

ABSTRACT

Container cranes (CC) become the highest electric energy consumption equipment in container terminal. Therefore it is important to study and analyze the hoist motor as the largest motor on container crane operation to look for opportunities in use energy efficiently. Lifting and lowering the container as the fixed operation of CC. Lifting the container as forward operating of hoist motor and lowering the container as reverse operating of hoist motor. The type of DC motor have used to modelling. Simulink (one of Matlab toolboxes) was used to model the forward and reverse of DC hoist motor. When lifting the container (forward motoring), the current required depends on the applied load torque. But when lowering the containers (reverse motoring), the voltage generated by the engine polarity reverse is determined by the downward movement of containers (mass and height). Reverse the polarity, and let the motor functions as a generator, produces a current and then the potential energy was calculated. Conclusions were drawn at the end of the paper.

Keywords-Container Crane, DC Hoist Motor, Forward, Reverse, Potential Energy.

I. INTRODUCTION

One of the real activity contribute to air pollution in container terminal is the use of diesel engines for loading and unloading equipment such as cranes. Container cranes (CC) are used to move containers from ship to shore or otherwise. Container crane uses several large electric motors as the driving force to lift and move the containers weighing dozens of tons. It causes container cranes become the highest electric energy consumption equipment in container terminal [1,2].Therefore it is important to study and analyze the hoist motor as the largest motor on CC operation to look for opportunities in use energy efficiently.

Container cranes can move containers in three degrees of freedom by using hoist, trolley, and gantry motors. The hoist motor is used to raise and lower the container, trolley motors move the container from one side of the crane to the other, and gantry motors are used to reposition the entire crane [3].The electric motor will drive the spreader back and forth as well as up and down to move the container. Spreader serves to lift containers from and to the ship. This is called the spreader due to its size can adjust the length of the container to be lifted or lowered [3].

Fig.1 represented the container crane movement



Fig.1. Container Crane Mechanism [4]

This paper focuses on conducted with the hoist motor.

II. DC MOTOR OPERATION

Some of container terminal use DC type for CC hoist motor as local at Makassar container terminal. DC motor's working principle is simpler than that of the AC motors, they are also easier to control and require simple electronics to operate. But, they have a lower efficiency, require maintenance of the brushes and the commutator, and heavier also larger than AC motors. Fig. 2 shows the brush DC motor model.

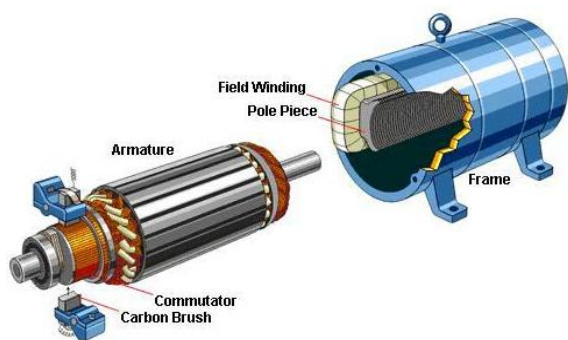

Fig. 2. Brush DC motor model [5]

Torque in electric motors is produced due to the interaction among electromagnetic fields. The torque and the electromagnetic field are related according to the Lorentz force. DC motors powered with direct current, and to get the rotation of the magnetic field, they need something that changes the current direction through the coils. This is achieved the use of the commutator, which is rotating together with the rotor, and is divided in two sections (two-pole motor). Each part is permanently in contact with the brushes that drive the current to the rotor, and due to the change of position in the commutator, the current runs through the armature windings in different directions each time, producing a rotating magnetic field [6].

The equivalent circuit of the separately excited DC motor is shown in Fig. 3 [7,8]. I_a and I_f are the armature and field currents, R_a and L_a are the armature resistance and inductance, R_f and L_f are the field resistance and inductance, U and U_f are armature and field voltages, n and ω are the speed in r/min and rad/s, respectively, E is the back EMF (electromotive force) and T_e is the electromagnetic torque.

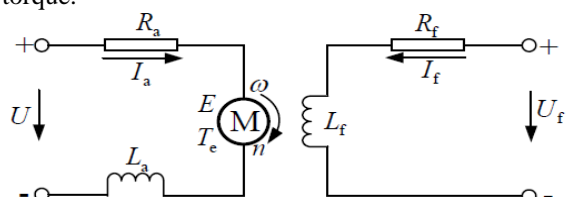

Fig. 3. Equivalent circuit of the separately excited DC motor.

The key set of equations for the separately excited DC motor is listed below [9]:

$$E = K_e \phi \omega = K_a \phi I_a = L_{af} I_f \omega \quad (1)$$

$$T = K_a \phi I_a \quad (2)$$

$$U = E + R_a I_a \quad (3)$$

Where ϕ is the air-gap flux, K_e and K_a are determined by the DC motor structure and L_{af} is the field-armature mutual inductance. The speed equation is:

$$n = \frac{U}{K_e \phi} - \frac{R_a}{K_e K_e \phi^2} T_e \quad (4)$$

And the power is

$$P = \omega T = V * I_a - I_a^2 * R_a \quad (5)$$

P is mechanical power, $V * I_a$ is electric power and $I_a^2 R_a$ is losses on motor construction.

The operation scheme of a DC machine, ie, torque and voltage as shown in Fig.4.

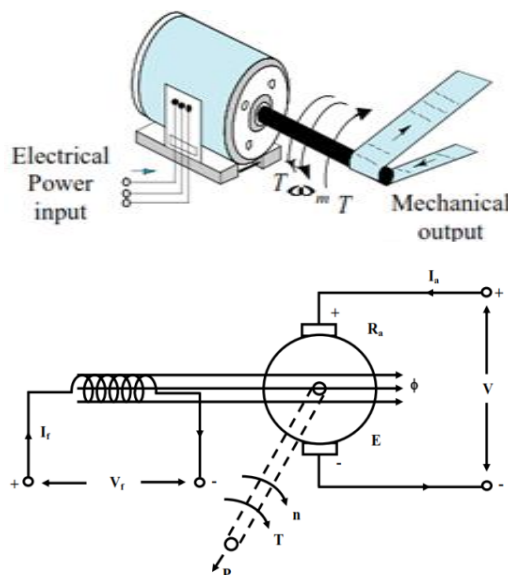

Fig.4. Torque Scheme of separately excited DC motor.

An armature voltage controlled DC machine is therefore inherently capable of what is known as ‘four-quadrant’ operation, with reference to the numbered quadrants of the torque–speed plane shown in Fig. 5 [7].

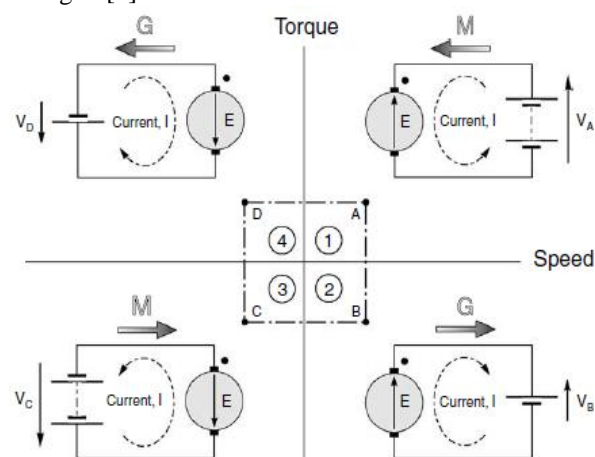

Fig.5. Operation of DC motor in the four quadrants

DC machine speed is determined by applied voltage and torque is determined by current. For the operation of the four quadrants, each quadrant are given each naming the quadrant 1 is called the condition A, quadrant 2 is called the condition B, quadrant 3 is called the condition C and the fourth quadrant is called the condition D, which is where all

of the conditions have the same magnitude of speed and the same magnitude of torque.

In quadrant 1, the applied voltage V_A at point A will flow toward the electric machine which has e.m.f E consequently machine moves forward as a motor with torque and speed are same direction, this happens because the $V_A > E$. When taking into account the resistance of conductor R so $V_A = E + IR$. In quadrant 2, the applied voltage at point B for V_A decrease to a very small that is $V_A = E - IR$ causing reverse torque to the speed turned to $E - V_B = V_A - E$ where V_A is the voltage at A condition and V_B is the voltage at B condition. When these conditions change the electrical machinery before as the motor is now the generator with the voltage generated with $V_A - E$. This value will be negative, or in other words, the output voltage polarity of generator is opposite from the motor.

It should be obvious that similar arguments to those set out above apply when the motor is running in reverse (i.e. V is negative). Motoring then takes place in quadrant 3 (point C), with brief excursions into quadrant 4 (point D, accompanied by regenerative braking), whenever the voltage is reduced in order to lower the speed.

III. CONTAINER CRANE DC HOIST MOTOR

The hoist motor as container cranes drive using large energy at the container terminal. Hoist motor of container crane serves to move the spreader in the direction up or down. Worked continuously during loading and unloading operations. The CC hoist motor is the largest motor, mounted on machinery house. Movement of the lift and lower box container is fixed operation of CC hoist motor. Diagram for forward and reverse motoring of hoist motor as shown in Fig. 6.

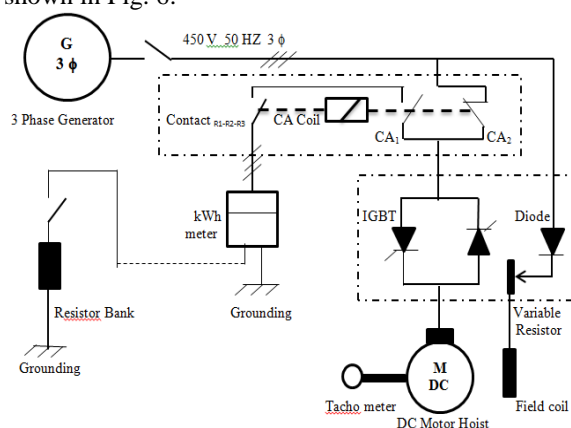

Fig.6. DC hoist motor diagram

When a container is lifted by container crane, the diesel engine provides the energy demanded by the hoist motor. When the container is lowered, the

container's potential energy is converted by the hoist motor into electrical form.

Fig. 7 shows the position of the container being lifted or lowered by the spreader.



Fig.7. Lifted or lowered position of container

The required energy to lift the container in accordance with the load (mass of container) and the distance (height) movement of container to be lifted. Motor will move / rotate to lift the container (forward motoring, stage 1). It is shown on the following scheme (Fig.8)

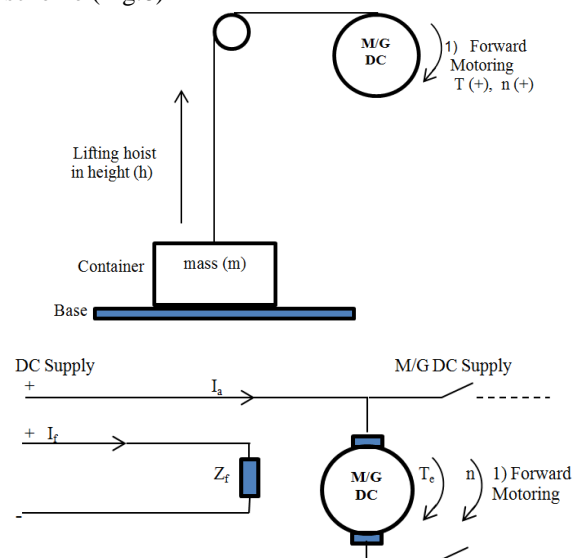
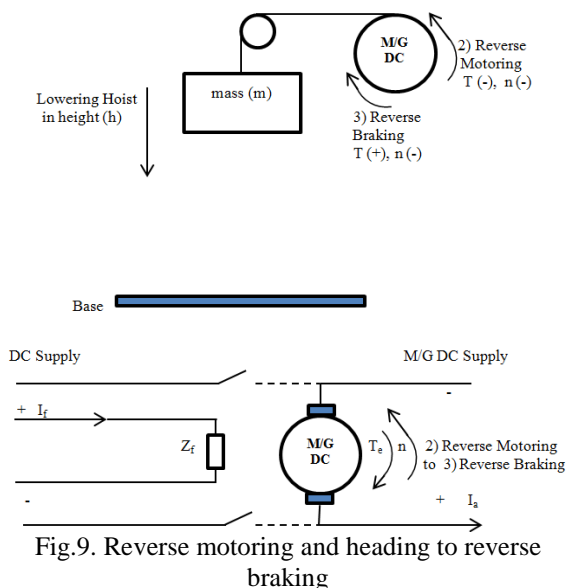

Fig.8. Forward motoring of CC hoist motor scheme

And then for lowering the container the hoist motors will take a reverse direction of the previous lifting container. Thus there is the potential energy accordance to the mass of container to be lowered and the distance (height) down movement of the container. Fig.9 for represented the lowering mode



Potential energy that occurs when lowering the container will result the reverse rotation direction of motor (reverse motoring, stage 2) which would exceed the capacity of engine rotation speed, so it should be braking (reverse braking, stage 3). Braking is one needs to slow down the movement of the object and delete inertia. With the use of either the alternator in the motor, we can reverse the polarity, and let the motor functions as a generator, produces a current. In ideal condition to the exclusion of some losses factors, The potential energy which can be obtained in this operation is determined by the equation [10].

$$E_p = mxgx(h_2 - h_1) \quad (6)$$

$$P_p = \frac{E_p}{t} \quad (7)$$

The electric motor as container cranes drive using large energy at the container terminal. In its operations definitely also require braking. Especially when lowering the container by the hoist motors. As stated by [11] that the electric motor has two mechanical operations, moving and braking. During braking, the initial energy stored in the rotor is either dissipated in an external resistance, storage device or fed back to the supply or both [12].

Existing Condition, as local Makassar container terminal's CC hoist motor :

1. The system uses a diesel engine as the prime mover for the rotation of the AC generator as a electrical power supply to the CC hoist motors.
2. CC uses a DC motor for moving the hoist. The braking system in form of electrical and mechanical when lowering the container. Electrical by connecting the electrical output through a DC motor armature current of the motor turns into a generator to the resistor bank (the current in armature coil of DC motor will form on the coil e.m.f fields that will slow down motor

rotation that has been turned into a generator). Mechanical Braking is to lock the disc break.

Data:

1. AC Generator 450 kW, 500 V, 50 Hz
2. DC Motor
 - a. DC Motor 250 HP, 2 pole, 1750 rpm
 - b. Field Voltage (V_f) = 300 V DC
 - c. Field Current (I_f) = 16.9 Amper
 - d. Armature Voltage (V_a) = 500 V DC
 - e. Armature Current (I_a) = 604 Amper
 - f. Torque = 993 Nm (sample).
 - g. Armature Resistansi = 83 mohm
 - h. Armature Inductance = 1.64 mH
 - i. Inertia moment = 7 kg.m²
3. Container (sample), mass (m) = 18 ton
4. Height , h (lifting from base = 19.56 meter)
5. Gravity 9.81 m/dt²

In this study, a popular simulation tool, Simulink (one of the MATLAB toolboxes). The very beginning step for using the Simulink is to model the system by either using mathematical expression or circuit representation. In this case, circuit representation ways were used complimentary to assist the design of the model.

IV. RESULTS

4.1. Lifting the container mode (Forward Motoring)

Fig. 10. represented the armature current in lifting the container mode (forward motoring) as a time function.

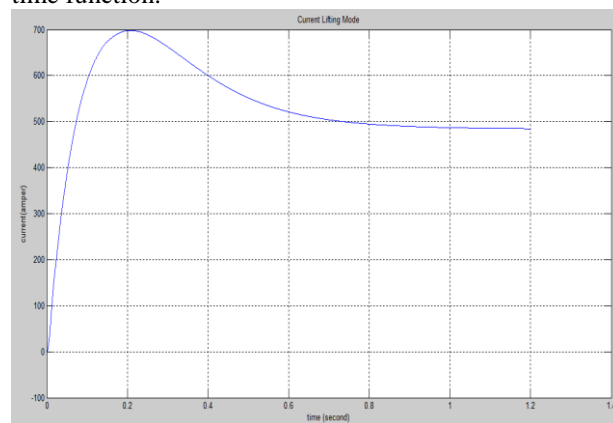

Fig.10. Armature current in forward motoring

For this forward and reverse motoring, load torque (T) = 993 Nm was imposed.

From the simulation results shown in the fig.10 : In forward motoring, current starting at t = 0 sec is increased significantly and had reached the maximum as starting current (I = 700 A) at t = 0.2 sec. After that, decrease until I = 500 A at t = 0.8 sec. Then, decrease in small currents occur until at t = 1.0 sec. And so the armature current hast ends to be constant (I = 487A) at t = 1.0 sec. This current has tended to accordance the load torque given.

4.2. Lowering the container mode (Reverse Motoring)

Fig. 11 represented the armature voltage in lowering the container mode (reverse motoring) as a time function.

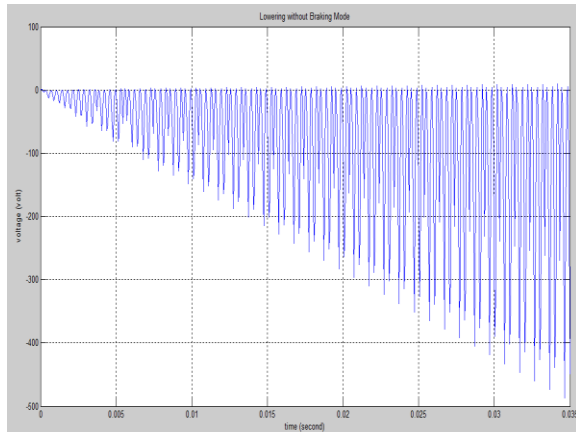

Fig.11. Armature voltage in reverse motoring

When lowering the container, the load torque minus (-993 Nm) is given. From the simulation as in Figure 11, reverse polarity occurs when the motor turns into a generator due to the direction of rotation has changed than before. Output Voltage generated by the motor that has been turned into a generator is increase as the rotation speed of the rotor. Output voltage is discontinuous caused by the effects of the commutator in contact with carbon brush. A part of commutator has some holes / cracks that form to separate the coils between the magnet poles. The output voltage of the motor which has been turned into a generator through the process : current flowing coil or stator field will cause magnet pole with north and south, the two poles crossed by slit coil so that the effects will cause the electric field at each of the ends coil.

In the reverse direction simulated (generator mode) the voltage has been get in the $V = 450.4$ volts at very short $t = 0.035$ sec. This is caused by the speed of the motor that turns into a generator will continue to follow the increase in free fall speed stationary objects (container). If allowed to continue it will reach the armature voltage exceeds the voltage armature construction machinery and also causing motor shaft rotation exceeds the nominal speed. So this must be done braking. For simulated samples, the braking should be done in prior to $t = 0.035$ sec because at this time the voltage $V = 450$ volts is approach in machine armature voltage. Reverse the polarity, and let the motor functions as a generator, produces current. In this case, the potential energy which can be obtained in this operation is determined by the equation (8):

$$E_p = mxgx(h_2 - h_1)$$

$$E_p = 18 \text{ ton} \times 9.81 \text{ m/sec} \times 19.56 \text{ m}$$

$$E_p = 3,453 \text{ kilojoule}$$

When braking period at lowering process, a torque opposite to the direction of rotation will be imposed on the shaft, thereby helping the machine to stop quickly. During braking, the energy stored in the rotor is either dissipated in an external resistance, storage device or fed back to the supply or both.

V. CONCLUSIONS

One of its technical issues in the CC operation is the movement as the CC lifting and lowering the container. DC hoist motor on CC operation has been successfully modelled using Simulink and forward reverse motoring was investigated.

In lifting the container mode (forward motoring), after starting condition, this current has tended to stable accordance to the load torque given.

In lowering the container mode the reverse polarity than forward motoring before. The generated voltage is in accordance to the rotation of the rotor shaft due to down ward of container. The motor functions as a generator, produces a current and the potential energy was determined.

REFERENCES

- [1] Green Cranes. *Green technologies and eco-efficient alternatives for cranes and operations at port container*, 2013.
- [2] MSC Terminal Valencia, *Arrival and container specifications terminals*. Green Cranes Consortium and TEN-T EA., (2012, December).
- [3] M. Flynn, P. McMullen, Solis, High-speed flywheel and motor drive operation for energy recovery in a mobile gantry crane, *Center for Electro mechanics, University of Texas, VYCON, Inc. 12880 Moore Street, Cerritos, CA 90703, O. Solis. VYCON, Inc. 12880 Moore Street , Cerritos, CA 90703.*
- [4] Nader A. Nayfeh, *adaptation of delayed position feedback to the reduction of sway of container cranes*, Thesis, Virginia Polytechnic Institute and State University, Blacksburg, Virginia, December 4, 2002.
- [5] http://www.electrical_knowhow.com/2012/05/classification-of-electric-motors.html.
- [6] Eloy Pedro Sánchez Caton, *Dynamic braking a new approach for testing electrical machines*, Division of Industrial Electrical Engineering and Automation, Faculty of Engineering, Lund University *CODEN:LUTEDX/(TEIE-5292)/1-65/(2012).*

- [7] Austin Hughes, *Electric Motors and Drives, Fundamentals, Types and Applications*, Third edition, Newnes is an imprint of Elsevier, Third edition 2006.
- [8] Li, J., Ma, H. and Chen, H., English in Electric Automation. Harbin, PRC: *Harbin Institute of Technology Press*,96-109 (2005).
- [9] Guoqiang Chen and Xianguang Shang, Simulation used in education for a separately excited DC motor, Henan Polytechnic University , Jiaozuo City, People's Republic of China, *World Transactions on Engineering and Technology Education 2014 WIETE* Vol.12, No.1, 2014
- [10] Lynn Vanheule, et al; *Creating a sustainable harbour making use of regenerative braking and renewable energy sources*.
- [11] Aravind Samba Murthy, *Analysis of regenerative braking in electric machines*, thesis, School of Electrical and Computer Engineering, Georgia Institute of Technology, May 2013.
- [12] Lesson 39, D.C Motors. Version 2 *EE IIT, Kharagpur*

First Author:

Rukmini, Doctoral programs in Civil Engineering, Hasanuddin University. She graduated from Electrical Engineering, Hasanuddin University, Indonesia 1997. She worked as a Lecturer in Makassar Merchant Marine Polytechnic (PIP Makassar, Indonesia), from 2001 until present.