

## A Comparative Study on Performance Parameters of a Conventional Silencer versus Helmholtz Silencer Implemented On A 100cc Motorcycle

Saurabh Jadhav\*, Apoorv Prem\*\*

\*(Department of Automobile Engineering, Government College of Engineering & Research- Avasari, Pune, Maharashtra, India-412 405)

\*\* (Department of Automotive and Aeronautical Engineering, Manipal Institute of Technology, Manipal, Karnataka, India-576 104)

### Abstract

Automotive noise and pollution control are critical fields of study and research in recent years. Researchers all across the globe are focusing on making vehicles environmentally friendly by reducing sound and air pollution achieved through implementing various modern technologies. This paper concentrates on the study of noise and pollution performance of a 100cc motorbike on a custom fabricated Helmholtz silencer over a conventional silencer.

### I. INTRODUCTION

Modern day automobiles are getting more and more clean and safe, thanks to new inventions and sophisticated technologies. Vehicle refinement is a new term introduced and evaluated as vehicle performance parameter alongside emission effectiveness.

The internal combustion engine is a major source of noise pollution. Engine noise is classified as aerodynamic noise- due to the flow of gases and surface radiated noise- due to vibration of engine components. Sources of engine noise include intake system, combustion and exhaust system out of which exhaust noise is attenuated by the use of mufflers. Excess engine noise also deteriorates the ride quality and indicates lower finesse. Furthermore, automobiles are a source of air pollution too. Emissions as a result combustion process led directly into atmosphere are of major concern because of their negative impact on air quality, human health, and global warming. Government bodies implement, control and regulate emission standards for primary pollutants such as unburned hydrocarbons (HC), carbon monoxide (CO), nitrogen oxides (NO<sub>x</sub>), and particulate matter (PM).

It is the role of an automotive design engineer to develop vehicles with greater environmental potential keeping detrimental effects as such to a minimum. The following study involves testing of a motorbike- '1995 Hero Honda CD 100 SS' for its performance based on certified vehicular noise tests as well as government regulated emission control norms.

### II. HELMHOLTZ SILENCER

Based upon the vehicle parameters, operating conditions and performance requirements an exhaust system has been designed and fabricated. It is called the 'Helmholtz Silencer' which is a combinational muffler working on rules of reactive silencing and absorptive silencing all together with Helmholtz principle. The bike is equipped with a factory fitted conventional dissipative exhaust system which produces a high pressure pulsating flow of charge generating noise up to 110dB at engine speed of 5800rpm. As per the Helmholtz principle of reactive silencing, the silencing system has to be a compromise between efficient attenuation and frequency band of effective attenuation. However, in a vehicle running under normal road conditions i.e. at 45-60kmph, the exhaust pulse ranges from 0.5 to 0.2 milliseconds which produce a natural frequency of around 200-500Hz. For an effective Helmholtz resonator with minimum insertion loss, we considered the super critical grade for efficient noise cancellation. Critical dimensions of inlet pipe, chambers and tail pipe were determined by applying acoustic engineering principles and a three chamber layout was advised.

The developed design is one with a radial inlet, single tube muffler having three chambers- reaction chamber, expansion chamber and diffusion chamber. The housing is built using chromium-nickel steel pipe with 2mm thickness and sealed on both ends. The tube is insulated using braided glass wool for acoustic absorption. The reactive chamber has a concave brass diaphragm to reflect sound waves back to the source in radial direction which lowers the kinetic energy of gaseous charge. The charge passes

across a steel partition wall with radial drilled holes which act as coherent sources of sound which are out of phase with each other and produce a further reduction in noise level by formation of destructive wave interference. In the expansion chamber we have incorporated an activated carbon filter to absorb hydrocarbon emissions/HC and lower the amount of CO-CO<sub>2</sub> by scrubbing action. The resulting gas pressure is reduced from 4 to 1.4atm with a corresponding rise in velocity. The product is works similar to a free flow exhaust system delivering high flow rates and minimum reduction in engine power or fuel consumption due to back pressure.

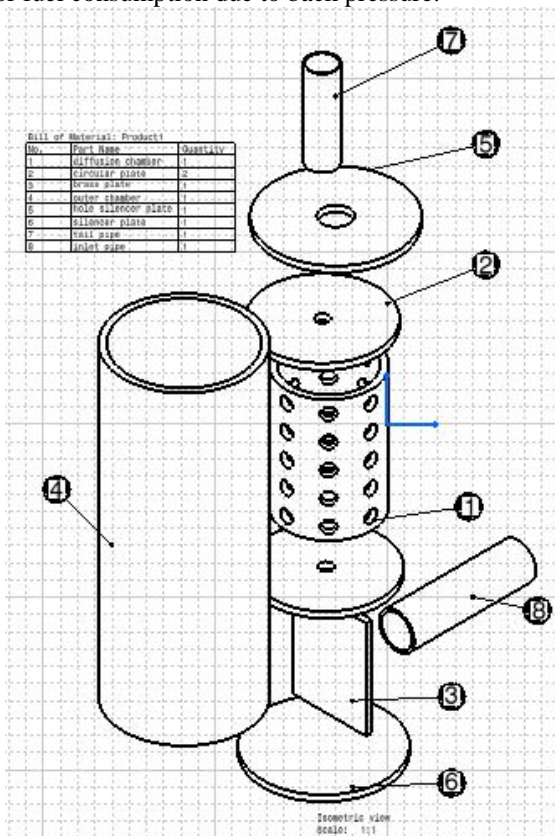

Fig. 1: 2D Assembly

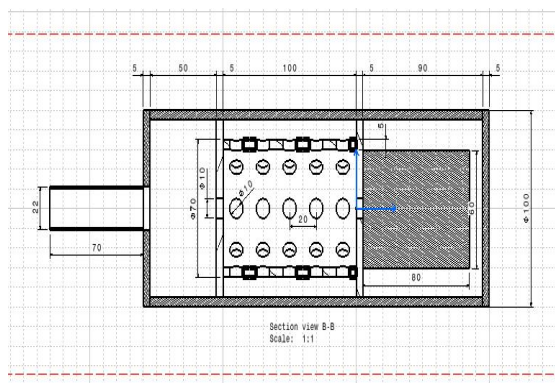

Fig. 2: 2D sectional view

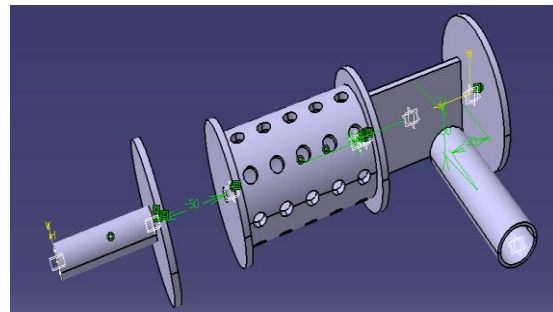

Fig. 3: 3D internal assembly

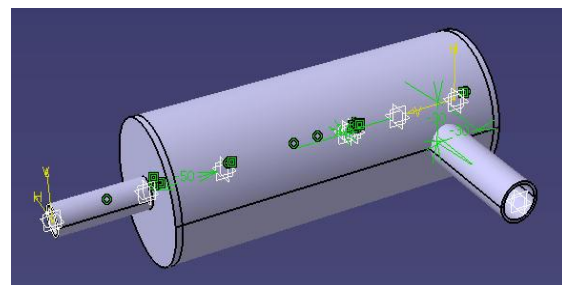

Fig. 4: 3D complete silencer



Fig. 5: Actual built silencer

### III. INDIAN EMISSION NORMS

The Bharat Stage (BS) emission standards are instituted by Government of India to regulate the output of pollutants from internal combustion engines including those in motor vehicles. These standards, based on European homologations were first introduced in India in the year 2000 and progressively stringent norms have been imposed ever since. All new vehicles manufactured after the implementation of these norms have to be compliant with the regulations.

India emission standards			
Standards	Reference	Date	Region
India 2000	Euro 1	2000	Nationwide
Bharat Stage II	Euro 2	2001	NCR*, Mumbai, Kolkata, Chennai
		Apr 2003	NCR, 10 cities**
Bharat Stage III	Euro 3	Apr 2005	Nationwide
		Apr 2005	NCR, 10 cities**
Bharat Stage IV	Euro 4	Apr 2010	Nationwide
		Apr 2010	NCR, 10 cities**

Source: Cygnus Research, Dieselnet  
 \*NCR ( Delhi)  
 \*\*Mumbai, Kolkata, Chennai, Hyderabad, Bangalore, Ahmedabad, Pune, Surat, Kanpur and Agra

Fig. 6: Indian Emission Standards-timeline

These emission norms are expressed in terms of grams per kilometer of gas emitted from the vehicle.

**Table I**  
**Bharat Stage Emission Norms for Gasoline powered 2 wheelers**

Year	CO	HC	HC+NO <sub>x</sub>
1991	12-30	8-12	-
1996	5.50	-	3.60
2000	2.00	-	2.00
2005 (BS II)	1.5	-	1.5
2010.04 (BS III)	1.0	-	1.0

Substance	Standard
Carbon Monoxide	40 milligrams/cubic meter [35 ppm] for 1-hour average
Hydrocarbons	0.16 milligrams/cubic meter [0.24 ppm] for 3-hour average
Oxides of Nitrogen	0.1 milligrams/cubic meter [0.05 ppm] for annual average
Sulfur Dioxide	0.08 milligrams/cubic meter [0.03 ppm] for annual average
Particulates	0.075 milligrams/cubic meter for annual average

Fig. 7: Ambient air quality standards for each pollutant. (Society of Automotive Engineers, Inc.)

Fig. 7: SAE emission standards for a standard 100cc four stroke gasoline engine motorcycle

#### IV. VEHICLE NOISE TESTS

Vehicle refinement is the subjective assessment of quality of automobiles measured in terms of 'Noise-Vibration-Harshness' i.e. NVH specifications. Similar to any other measurable performance criterion, government and other legislative bodies stipulate noise levels from different sources in an automobile measured by precise testing methods. Exhaust noise from a stationary vehicle is measured by following tests-

1. EC Homologation 92/97/EEC
2. US Homologation (SAE J986 & J1030)
3. ISO 5130

##### 1. EC Homologation 92/97/EEC

This test is for a stationary vehicle exhaust noise measured at conditions explained as per 70/157/EEC which defines limiting noise levels from outside the vehicle during a particular form of acceleration test. The current homologation levels correspond to the test detailed in 92/97/EEC. ISO 362:1998 is broadly

similar but not identical in all details. In particular, 92/97/EEC requires additional measurements to be made 0.5m (45° angle of incidence, 0.2m above the ground) from the exhaust tailpipe of a stationary vehicle in order to facilitate subsequent checks of vehicles in use. The engine is run at three-quarters speed and the maximum sound pressure level (fast, A-weighted) is recorded. The results from three of these tests must be reported as part of the vehicle certification process. 92/97/EEC also includes a method for assessing compressed air noise.

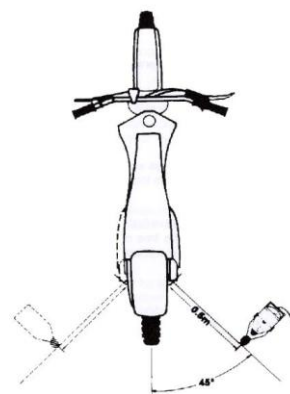

SOUND LEVEL AND MICROPHONE LOCATION AND ORIENTATION

Fig. 8: Sound Level Measurement

The test track conditions are maintained as:

Directive 92/97/EEC introduced a requirement for a standard road surface to be adopted at all test tracks used for drive-pass noise homologation. 92/97/EEC is not completely prescriptive over the details of construction for such a standard track and so many Member States have adopted ISO 10844 as a specification. According to Sandberg (1991), the specification in ISO 10844 was aimed initially at achieving three goals:

- To make the results achieved at any given track repeatable and reproducible at any other track.
- To make the track surface highly reflective so that all noise sources on the vehicle (even those hidden from view under the vehicle) make a contribution to the overall drive-pass level and thus this would encourage manufacturers to treat the whole vehicle.
- Minimize the noise radiated from the tire/road contact as this is a fairly unavoidable source of noise and if it were to dominate, manufacturers would not be incentivized to treat the noise from other sources on the vehicle.

Before the widespread adoption of ISO 10844 surfaces, Dunne and Yarnold (1993) reported that they knew of 4 dBA variations in the drive-pass noise levels recorded for the same car at different test tracks around Europe.

\*\*\*ISO 10844: The ISO 10844 surface did indeed behave as a close approximation to a perfectly

reflective (low absorption) surface at most frequencies of interest.

- The sound absorption characteristics of the ISO 10844 track are more uniform across the frequency spectrum than those of the high-drainage asphalt surface. This suggests consistent surface characteristics over the 7.5m acoustic path length and should result in results being more repeatable and reproducible.
- Because of the relative smoothness of the ISO 10844 surface, low-frequency tire noise was reduced compared with the high-drainage surface, but high-frequency tire noise was increased.

Table 3.1 EC homologation noise levels for type approval

EC Directive Enforced for new vehicles	70/157/EEC 1976	77/212/EEC 1983	81/334/EEC 1984**	84/424/EEC 1990	92/97/EEC 1996
Category of vehicle	Maximum permissible noise level (dBA) at 7.5 m (acceleration test)				
Cars (<9 seats)	82	80	80	77	74*
Minibus <2 tonnes	84	81	81	78	76
Minibus 2-3.5 tonnes	84	81	81	79	77
Bus ≤150kW	89	82	82	80	78
Bus >150kW	91	85	85	83	80
Light Truck <2 tonnes	84	81	81	79	76
Light Truck 2-3.5 tonnes	84	81	81	80	77
Truck >3.5 tonnes					
≤75kW	89	86	86	83	77
75-150kW	89	86	86	85	78
>150kW	91	88	88	86	80

\* 75 dBA if fitted with a DI diesel engine or if very powerful 'supercar'.  
 \*\* Imposed more stringent requirements for exhaust and intake systems.

Fig. 9: EEC: permissible sound levels from a motorcycle

## 2. SAE J986 and J1287

Most countries outside the EC have their own systems of vehicle approval that include restrictions on noise levels. Most tests for limiting noise levels are based on those of the EC or of the United States directives.

There are two US noise homologation tests – SAE J986 (AUG94) which has the vehicle entering a test area with predetermined vehicle speed and SAE J1030 (FEB87) which has the vehicle leaving the test area with predetermined engine speed. Both tests feature vehicle deceleration as well as acceleration. The acceleration part of SAE J986 (AUG94) is broadly similar to that in the EC test except that the microphone is positioned at 15m from the vehicle path line (rather than 7.5 m) and the test area is much longer (53 m) with the aim of allowing the vehicle to reach its rated engine speed during the test. In the EC test, the vehicle will seldom reach its rated engine speed.

Generally, a vehicle that achieves noise homologation in the EC will achieve US Federal homologation with comparative ease. The SAE J1287 announces measurement of exhaust sound levels of stationary motorcycles. A precision sound level meter compliant with IEC 61672-1/SAE J184 and accuracy of 0.5dB is used to measure SPL while engine speed is maintained with a steady state accuracy of +/-3%.

Test facility shall be a flat, open free of any reflecting surfaces like cars, boards, etc within a 5m radius.

Readings are made with rider on normal riding position of the motorcycle held at a height of two inches above ground on a stand (with drive disengaged). The gearbox is in neutral position and engine speed is half of rated speed. Test readings are taken at both sides of the exhaust as shown in figure. The microphone or SLM is located behind the exhaust pipe at an angle of 45 with the longitudinal axis of the vehicle at a height of the tailpipe. The ambient sound level (including wind effects) at the test site due to sources other than the motorcycle being measured shall be at least 10dB lower than sound level produced by vehicle under test.

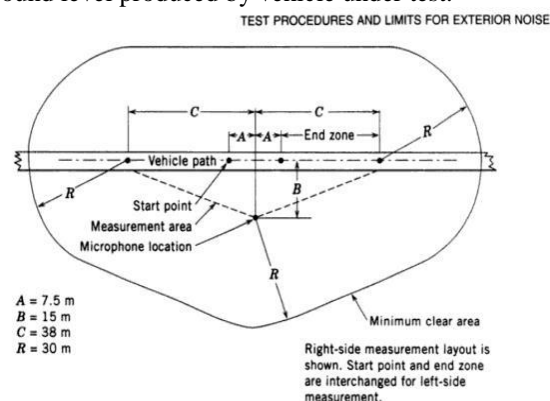

Fig. 10: Test Conditions SAE J986

MAXIMUM PERMISSIBLE SOUND LEVEL READINGS dB(A)			
OPERATION ANY SPEED		STATIONARY	
Soft Site (including snow)	Hard Site (including ice)	Soft Site	Hard Site
85 dB(A)	87 dB(A)	88 dB(A)	88 dB(A)
82 dB(A)	84 dB(A)	83 dB(A)	85 dB(A)
78 dB(A)	80 dB(A)	79 dB(A)	81 dB(A)

Fig. 11: SAE J986: Permissible sound levels for motorcycle

## 3. ISO 5130

It certifies a test for the measurement of sound pressure level emitted by stationary road vehicles. ISO (the International Organization for Standardization) is a worldwide federation of national standards bodies (ISO member bodies). The work of preparing International Standards is normally carried out through ISO technical committees. The (ISO 5130:2006) is second edition cancels and replaces the first edition (ISO 5130:1982), which has been technically revised.

The method is designed to meet the requirements of simplicity as far as they are consistent with reproducibility of results under the operating conditions of the vehicle. It is within the scope of this





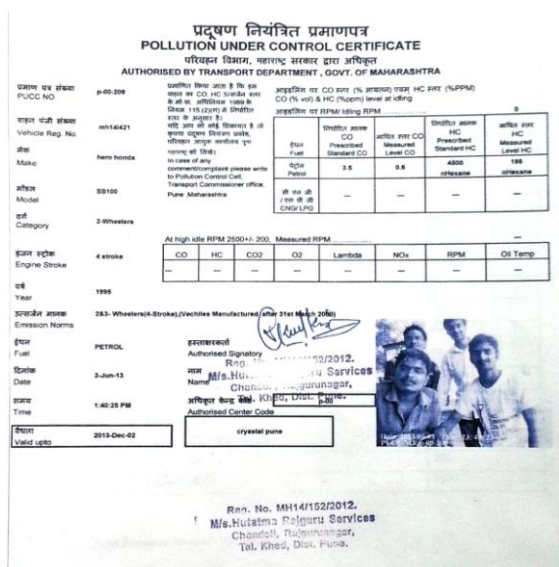

Fig. 14: PUC test over Helmholtz silencer

**Table II**  
Emission test results

Pollutant	BS III regulation	Conventional silencer	Helmholtz silencer	Percentile reduction
CO	3.5g/km	1.03	0.6	41.7%
HC	4500ppm	248	186	25%
NOx	2.5g/km	2.47	2.09	15.3%

## 2. Noise Testing

Standard test conditions are maintained close to perfect and each test yields three outcomes. Tests are performed at college laboratory facility and premises with proper care for specifications.

**Table III**  
EC Homologation 92/97/EEC

Obs No.	Regulation	Conventional silencer	Helmholtz silencer	Percentile reduction
1.	80dB	69.2dB	35.6dB	48.5%
2.	80dB	64dB	32.2dB	49.6%
3.	80dB	65.5dB	38.3dB	41.5%

**Table IV**  
US Homologation- SAE J986 and J1030

Obs No.	Regulation	Conventional silencer	Helmholtz silencer	Percentile reduction
1.	85dB	72.6dB	53.2dB	26.7%
2.	85dB	68.8dB	47.1dB	31.5%

3.	85dB	70.4dB	56.7dB	19.4%
----	------	--------	--------	-------

**Table V**  
ISO 5130

Obs No.	Regulation	Conventional silencer	Helmholtz silencer	Percentile reduction
1.	85dB	53dB	31dB	41.5%
2.	85dB	64dB	37dB	42.2%
3.	85dB	60dB	33dB	45%

**Table VI**  
Overall test averages:

Obs No.	Regulation	Average percentile reduction
1.	EC Homologation 92/97/EEC	46.5%
2.	US Homologation- SAE J986 and J1030	25.8%
3.	ISO 5130	42.9%

## VI. CONCLUSION

By the research, different types of mufflers, their design and fabrication, and vehicle testing for noise and emissions by the implementation of this new design have been studied. The new design has proved more efficient than the conventional in terms of flow rate, pressure drop, heat dissipation and packaging constraints. The flow of combustion charge is continuous and non-pulsating similar to that of a free flow exhaust with minimum hindrance to power generated thus reduced fuel consumption. Whereas the efficacy of this type of muffler is limited over a specific range of operation below or beyond which the performance is poor. Also, its weight and cost are comparatively higher. As a part of future development the system would be idealized into an electro-mechanical one working as an active noise cancellation system.

## REFERENCES

- [1] Matthew Harrison, *Vehicle Refinement-controlling noise and vibrations in road vehicles* (Warrendale, PA: SAE International, 2004)
- [2] *Society of Automotive Engineers, SAE Handbook*, 1996
- [3] *Central Motor Vehicle Regulations, cmvr1989*, (Rule115 and 126A, DOC.NO: MoRTH/CMVR/TAP-115-116, Issue No. 4)
- [4] Bosch, *Automotive handbook – Second edition*, (Robert Bosch GmbH, 1986)
- [5] SAE J1030 FEB87, *Maximum sound level for passenger cars and light trucks*, 1996

- [6] 92/97/EEC, *Council Directive of 10 November 1992 amending Directive 70/157/EEC on the approximation of the laws of the Member States relating to the permissible sound level and the exhaust system of motor-vehicles*, *Official Journal of the European Communities*, (No. L 371/35, 19.2., 1992)
- [7] ISO 10844: 1994, *Acoustics – Test surface for road vehicle noise measurements*, (International Organization for Standardization, 1994)
- [8] SAE J986 AUG94, *Sound level for passenger cars and light trucks*, 1996 *SAE Handbook*, (Society of Automotive Engineers, 1996)
- [9] Sandberg, U., *Standardization of a test track surface for use during vehicle noise testing*, (SAE Paper No. 911048, 1991)
- [10] Dunne, J.M., Yarnold, I.C., *Vehicle noise legislation – an overview*, (Proc. IOA, Vol. 15: Part 1, pp. 1–8, 1993)