

## Design and Simulation of DSTATCOM Using Phase Shift Control Based On Sinusoidal Pulse Width Modulation

Amrita Saraf, Arti Bhandakkar

PG Scholar, Department of Electrical & Electronics Engineering, Shri Ram Institute of Technology, Jabalpur, India.

Associate professor, Department of Electrical & Electronics Engineering, Shri Ram Institute of Technology Jabalpur, India.

### Abstract

In this paper a DSTATCOM is modeled and simulated for power quality improvement at the distribution end using Sim power system toolbox . Voltage sag and swell are the major power quality problems. Power quality issue is an undesired deviation in voltage, frequency and power factor that results in malfunctioning of end user equipments. Custom power devices are used for solving power quality problems at the distribution end. Among these devices DSTATCOM is one of the efficient and effective device which improve voltage sag and swell by injecting current into the system.

**Keywords-** DSTATCOM, PQ (power quality problems ), sinusoidal pulse width modulation (SPWM), Voltage sag and swell, voltage source converter (VSC)

### I. INTRODUCTION

In recent years power engineers are increasingly concerned over Power quality due to following reasons:

- The most responsible reason is the newer-generation load equipment with microprocessor-based controls and power electronic devices such loads are more sensitive to power quality variations than was equipment used in the past.
- The another reason is the increased use of power electronics devices such as electrical drives ,fact devices, static relays etc due to the increased emphasis on improving overall power system efficiency . This is resulting in increasing harmonic levels on power systems and has many people concerned about the future impact on system capabilities. Increased awareness of power quality issues among the end users.
- Most of the systems are now interconnected in a network. Hence the processes are integrated in which the failure of any component can results into important consequences.
- The globalization of industries has increased the awareness about deficiencies in power quality around the world.
- The economic value of power quality is also one important reason for its increased concern. There is a big money associated with these power quality disturbances.

Many efforts have been taken by the utilities to meet the consumer's PQ requirements. Hence FACT devices and various other custom

power devices are introduced in the electrical system to improve the PQ of the electrical power [1],[2].

### II. POWER QUALITY ISSUES

POWER QUALITY is a term that mean different to different people. Institute of Electrical and electrical engineers (IEEE) standard IEEE 1100 defines power quality "as the concept of powering and grounding sensitive electronic equipment in a manner suitable for the equipment". In a simpler words PQ is a set of electrical boundaries that allows a part of equipment to work in a intended manner without loss of performance or life expectancy.

#### A. Voltage Sag: Major Power quality problem:

Voltage dip or sag is today's one of the most common power quality problem. It is a dip of .1 to .9 p.u. in rms voltage or current at the power frequency, for interval of 0,5 cycle to 1 minute or a voltage dip is a short time (10 ms to 1 minute) event during which a reduction in r.m.s voltage magnitude occurs. It is often set only by two parameters, depth/magnitude and duration. It affects both the phase-to-ground and phase-to-phase voltages in a three phase system.

Its causes are fault in the utility system, a fault within the customer's facility or a large increase of the load current, like starting of motor or a transformer energizing. Typical faults are single-phase, two or more-phase short circuits, which leads to high currents. These high current results in a voltage drop over the network impedance. At the fault location the voltage in the faulted phases drops

close to zero, whereas in the non-faulted phases it remains more or less unchanged [17, 18].

In an industry voltage dips occur more often and cause severe problems and economical losses. Voltage dips mainly have their origin in the higher voltage levels not from end user equipment. Faults due to lightning, is one of the most common causes to voltage dips on overhead lines. If the economical losses due to voltage dips are significant, their mitigating process can be advantageous for the customer and even in some cases for the utility. As there is no standard solution which will work for every situation, each mitigation action must be properly planned and calculated.[3]

**B. Solutions of power quality problems:**

As for the Custom Power requirements [7]-[8], utility distribution networks, sensitive industrial loads, and critical commercial operations can potentially suffer from various types of outages and service interruptions. These can cost significant financial losses per incident based on process downtime, lost production, idle work forces, and other measurable and non-measurable factors. The types of interruptions that are experienced are classified as power quality problems and are most often caused by voltage sags and swells, lightning strikes, and other distribution system related disturbances. In many instances the use of Custom Power equipment, such as Dynamic Voltage Restorers (DVR), Solid-State Transfer Switches (SSTS), or Distribution level Static Compensators (D-STATCOM), can be some of the most cost-effective solutions to mitigate these types of power quality problems. There have been numerous applications of Custom Power technologies [9,10,11,12,13, 14].

A DSTATCOM is employed at the distribution level or at the load end for power factor improvement and voltage regulation. DSTATCOM can be one of the viable alternatives to SVC in a distribution network. Additionally, a DSTATCOM can also behave as a shunt active filter, to eliminate unbalance or distortions in the source current or the supply voltage as per the IEEE-519 standard limits. Since a DSTATCOM is such a multifunctional device, the main objective of any control algorithm should be to make it flexible and easy to implement in addition to exploiting its multi functionality to the maximum.

**III. DISTRIBUTION STATCOM**

The DSTATCOM i.e. Distribution Static Compensator is a voltage source inverter based static compensator that is used for the correction of bus voltage sags and swells. The DSTATCOM is capable of generating continuously variable inductive or capacitive shunt compensation at a value more than

its maximum MVA rating. The DSTATCOM continuously checks the line waveform with respect to a reference ac signal, and therefore, it can generate the exact amount of leading or lagging reactive current compensation to reduce the amount of voltage fluctuations. [3]

A D-STATCOM, which is schematically depicted in Fig. 1 consists of a two level voltage source converter (VSC), a dc energy storage device, a coupling transformer connected in shunt to the distribution network through a coupling transformer [4], [5]. Such configuration allows the device to absorb or generate controllable active and reactive power. The D-STATCOM has been utilized mainly for regulation of voltage, correction of power factor and elimination of current harmonics. Such a device is employed to provide continuous voltage regulation using an indirectly controlled converter [6].

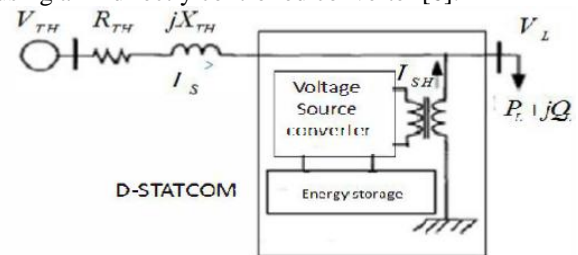

Fig.1. DSTATCOM connected at load end

**A. DSTATCOM main components:**

**1. IGBT or GTO based dc-to-ac inverters:**

These inverters are used which create an output voltage wave that's adjustable in magnitude and phase angle to produce either leading or lagging reactive current, depending on the compensation required.[3]

**2. L-C filter:**

An LC filter is used for decreasing harmonics and matching inverter output impedance to enable multiple parallel inverters to share current. The LC filter is selected as per the type of the system and the harmonics present at the output of the inverter. [3]

**3. Control block:**

A Control block is used which switches Pure Wave DSTATCOM modules as required. It can control external devices such as mechanically switched capacitor banks too. These control blocks are designed based on the various control theories and algorithms like instantaneous PQ theory, synchronous frame theory etc.[3]

In this paper, the D-ST A TCOM is used to regulate the voltage at the point of connection. The control is based on sinusoidal PWM and only

requires the measurement of the rms voltage at the load point.

**B. Principle Equations & Phasor Diagram Related to D-STATCOM**

**I. voltage regulation without compensator**

The source voltage E and PCC voltage V are shown in figure 2 & figure 3 when there is no voltage compensator, the PCC voltage drop caused by the load current  $I_L$  is as shown in fig.3 as  $\Delta V$

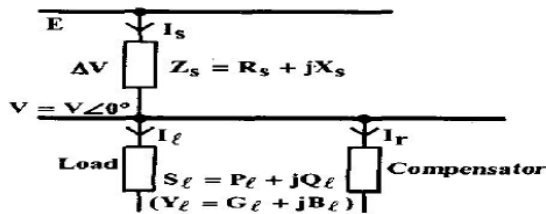

Fig.2. the equivalent circuit of load and supply system;

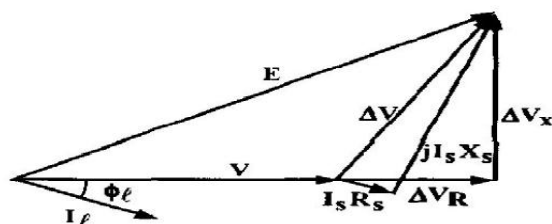

Fig.3. Phasor diagram of uncompensated line

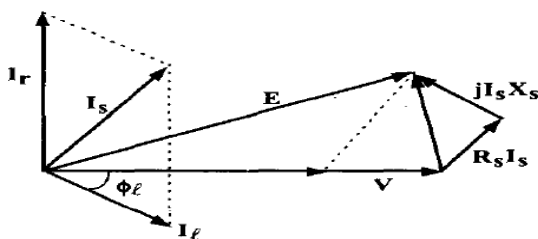

Fig.4. Phasor diagram of the compensated line

$$\Delta V = E - V = ZSIL \quad \dots\dots(1)$$

$$S = VI^*, S = V^*I \quad \dots\dots(2)$$

From above equation

$$I_L = \frac{PL - jQL}{V} \quad \dots\dots\dots(3)$$

$$\Delta V = (R_s + jX_s) \left( \frac{PL - jQL}{V} \right) \quad \dots\dots\dots(4)$$

$$= \left( \frac{RSPL - jRSQL}{V} \right) + \left( \frac{XSPL + jXSPL}{V} \right) \quad \dots\dots\dots(4)$$

$$= \Delta V_R + \Delta V_X \quad \dots\dots\dots(5)$$

The voltage change has a component  $\Delta V_R$  in phase with V and a component  $\Delta V_X$ , in quadrature with V, which are illustrated in Fig.3. it is clear that both magnitude and phase of V, relative to the supply voltage E, are the functions magnitude and phase of load current, namely voltage drop depends on the both the real and reactive power of the load[3]. The component  $\Delta V$  can be written as

$$\Delta V = I_s R_s - j I_s X_s \quad \dots\dots\dots(6)$$

**C. Voltage regulation using the DSTATCOM:**

Fig.3(c) shows the vector diagram with voltage compensation. By adding a compensator in parallel with the load, it is possible to make magnitude of E equal to magnitude of V by controlling the current of the compensator [3].

$$I_s = I_L + I_r \quad \dots\dots\dots(7)$$

Where  $I_r$  is compensator current.

It may be mentioned that the effectiveness of the DSTATCOM in correcting voltage sag depends on the value of  $Z_{TH}$  or fault level of the load bus. When the shunt injected current  $I_r$  is kept in quadrature with V, the desired voltage correction can be achieved without injecting any active power into the system. On the other hand, when the value of  $I_r$  is minimized, the same voltage correction can be achieved with minimum apparent power injection into the system.

**IV. CONTROL STRATEGY BASED ON SPWM**

The phase shift control strategy of DSTATCOM involves

Sinusoidal PWM based control. The main objective of this

type of control scheme is to maintain constant voltage magnitude at the load point (which is sensitive to system disturbances). This control scheme only involves the measurement of r.m.s. voltage at the load point and it does not require reactive power measurement [15,16]. Following fig.1 shows the block diagram of implemented scheme. Here the VSC switching strategy is based on sinusoidal PWM technique which offers simplicity & good response. This scheme consists of one PI controller which processes & determines the error signal then generates the required angle  $\delta$  to make the error to zero. There are two signals one is sinusoidal signal  $V_{control}$  & other is triangular signal  $V_{tri}$ . The sinusoidal signal is compared against the triangular signal to generate the switching signals for the VSC thyristors [15][16].

There are two main parameters amplitude modulation index  $M_a$  of signal of signal  $V_{control}$  & frequency modulation index  $M_f$  of the triangular signal. The  $M_a$  is kept fixed at 1p.u.

$$M_a = V_{control} / V_{tri}$$

The other is frequency modulation index  $M_f$  of the triangular signal,  $M_f = F_s / F_f$

Here,  $V_{control}$  is the peak amplitude of sinusoidal signal

$V_{tri}$  is the peak amplitude of triangular signal

signal

$F_s$  is the switching frequency

$F_f$  is the fundamental frequency

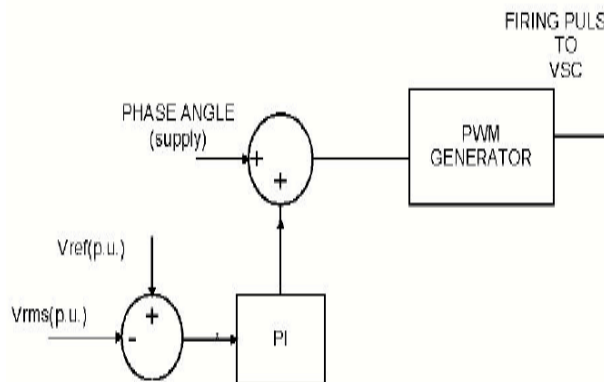

Fig.5. Phase shift Control scheme

### V. SIMULATION MODEL & DESIGN:

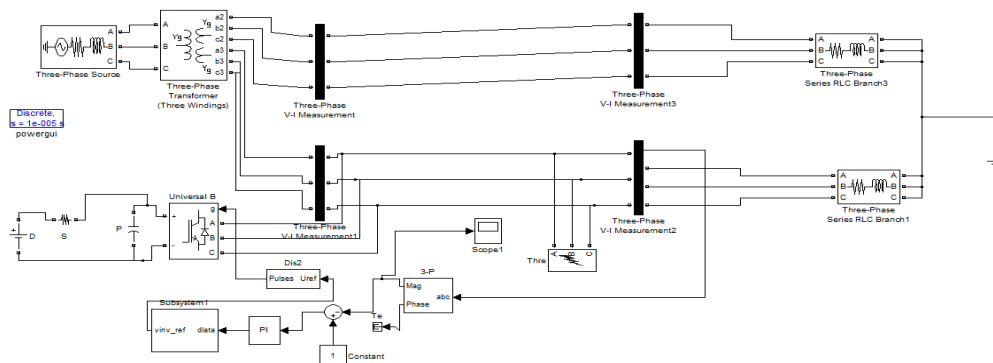

Fig.6. MATLAB / Simulink model of DSTATCOM connected to 11 KV double circuit Line

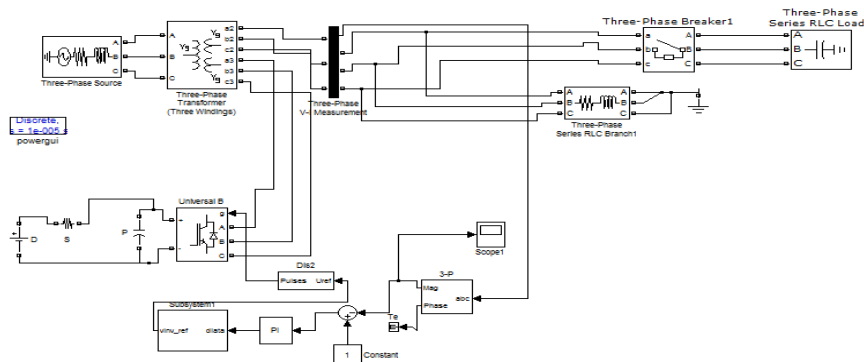

Fig.7. MATLAB / Simulink model of DSTATCOM connected to 11kv single circuit line with highly capacitive load

### VI. DESIGN AND SIMULATION:

The above fig.6 shows a test system which is used for performing different DSTATCOM simulations presented in the following section- A. The test system consists of 220 kV, 50 Hz, 3-phase generation system, represented by a Thevenin equivalent, supplying into the primary side of the 3-winding transformer. The secondary & tertiary side of transformer are feeding the 11kV double circuit line. Variable- loads are connected to each 11kV

circuit. A two-level DSTATCOM is connected to one 11 kV circuit to provide instantaneous voltage support at the load point. A fault box is inserted at the load end of the 11 kV circuit to create different types of faults in the system for producing variable voltage sags.

#### A. D-STATCOM Simulations and Results for Voltage Sag: Single Phase Disturbance-

CASE-1: The fig.8 shows that a voltage sag of 20% with respect to reference voltage occurs at the load end of the designed system, when a single phase short circuit fault is applied at point A, through a fault resistance of 0.6 Ω, during the period 400-600ms, with no DSTATCOM.

CASE-2: The fig.9 shows that the voltage is almost mitigated and the rms voltage at the sensitive load point is maintained at 99%, when DSTATCOM is connected in the same system.

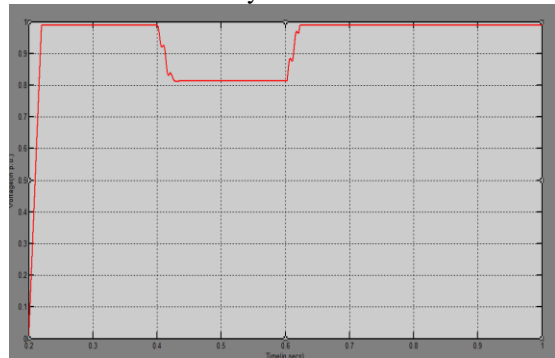

Fig.8.Voltage  $V_{rms}$  at load point with single phase fault ,without DSTATCOM

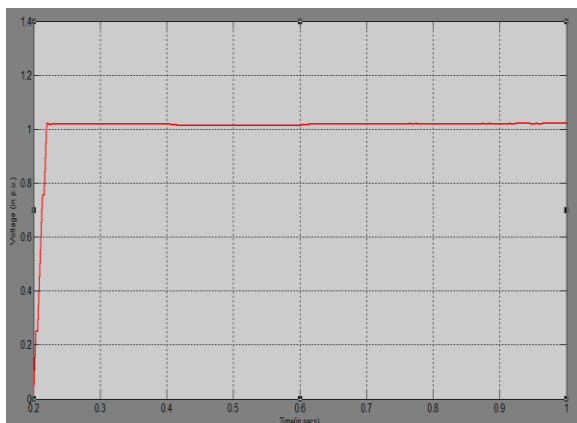

Fig.9.Voltage  $V_{rms}$  at load point with single phase fault, with DSTATCOM

**Double Phase Disturbance-**

CASE-3: The fig.10 shows that a voltage sag of 31% with respect to reference voltage occurs at the load end of the designed system, when a line-line short circuit fault is applied at point A, through a fault resistance of 0.4 Ω, during the period 400-600ms, with no DSTATCOM.

CASE-4: The fig.11 shows that the voltage is almost mitigated and the rms voltage at the sensitive load point is maintained at 99%, when DSTATCOM is connected in the same system.

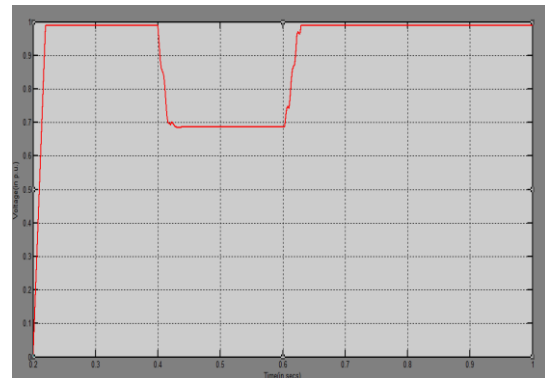

Fig.10.Voltage  $V_{rms}$  at load point with line-line fault, without DSTATCOM

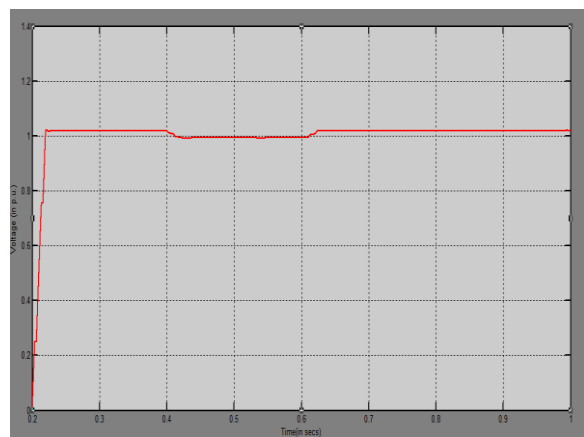

Fig.11.Voltage  $V_{rms}$  at load point with line-line fault, with DSTATCOM

**Three Phase Disturbance-**

CASE-3: The fig.12 shows that a voltage sag of 32% with respect to reference voltage occurs at the load end of the designed system, when a three phase to ground fault is applied at point A, through a fault resistance of 0.6 Ω, during the period 400-600ms, with no DSTATCOM.

CASE-4: The fig.13 shows that the voltage is almost mitigated and the rms voltage at the sensitive load point is maintained at 98%, when DSTATCOM is connected in the same system.

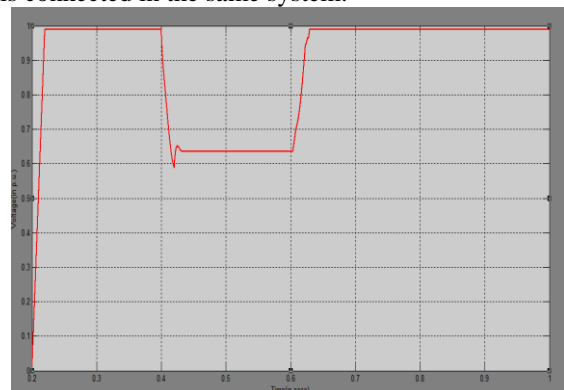

Fig.12.Voltage  $V_{rms}$  at load point with three phase fault, without DSTATCOM

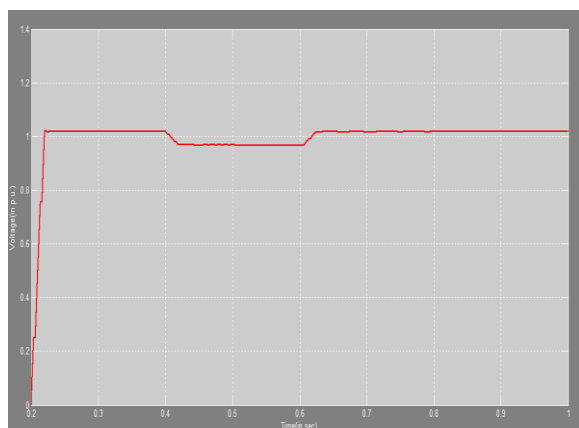

Fig.13.Voltage  $V_{rms}$  at load point with three phase fault, with DSTATCOM

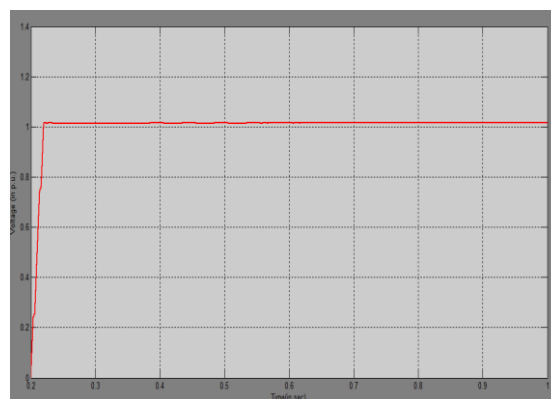

Fig.15.Voltage  $V_{rms}$  at load point with highly capacitive load, with DSTATCOM

### B. D-STATCOM Simulations and Results for Voltage Swell:

The fig.7.shows a test system which is used for performing different DSTATCOM simulations presented in the following section- B. The test system consists of 230 kV, 50 Hz, 3-phase generation system, represented by a Thevenin equivalent, supplying into the primary side of the 3-winding transformer. The secondary is connected to a varying load and to a capacitive load of power 10 kVAR.

CASE-1:The fig.14.shows that a voltage swell of 7% with respect to reference voltage occurs at the load end of the designed system, when a highly capacitive load is connected at point A during the period 400-600ms, with no DSTATCOM .

CASE-2:The fig.15.shows that the voltage swell is almost compensated and the rms voltage at the sensitive load point is maintained at 98%, when DSTATCOM is connected in the same system.

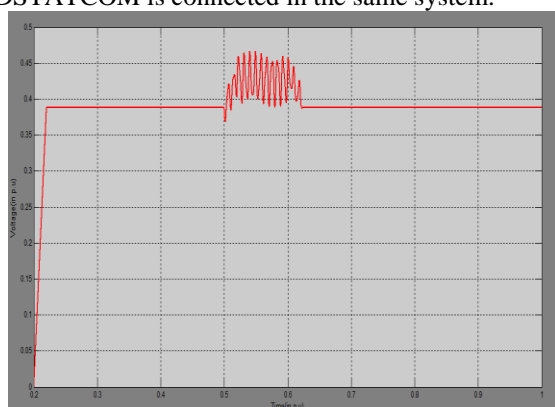

Fig.14.Voltage  $V_{rms}$  at load point with highly capacitive load, without DSTATCOM

## VII. CONCLUSION

In this paper voltage sags and swells were discussed. The application, design and compensation techniques of the custom power device DSTATCOM for voltage sags & swell correction were presented. The modeling and simulation of a DSTATCOM is done using Sim Power system toolbox of MATLAB/SIMULINK software .The control scheme of the voltage source inverter was implemented using SPWM technique .The system was tested under various operating conditions & it was found from the test results that DSTATCOM with SPWM control scheme provides relatively better voltage regulation capabilities in each case. By such a robust performance of the DSTATCOM system it can be concluded to be a much satisfactory device for improving the power quality at distribution end.

## REFERENCES

- [1] R.C. Dugan, S. Santoso, M.F. McGranaghan, and H.W. Beaty, *Electric Power System Quality*, McGraw-Hill, 2004.
- [2] N. Hingorani, "FACTS-Flexible ac transmission systems
- [3] P. Bapaiah , "Power Quality Improvement by using DSTATCOM" International Journal of Emerging Trends in Electrical and Electronics (IJETEE), Apr. 2013.
- [4] G. Venkataramana, and BJohnson, "A pulse width modulated power line conditioner for sensitive load centers," IEEE Trans. Power Delivery, vol. 12, pp. 844-849, Apr. 1997.
- [5] L Xu, O. Anaya-Lara, V. G. Agelidis, and E. Acha, "Development of prototype custom power devices for power quality enhancement," in Proc. 9th ICHQP 2000, Orlando, FL, Oct 2000, pp. 775-783.
- [6] W. Freitas, A. Morelato, "Comparitive study between power system bolckset and PSCAD/EMTDC for transient analysis of

- custom power devices based on voltage source converter," /PST, New Orleans, USA,
- [7] John J. Paserba Gregory F. Reed Masatoshi Takeda & Tomohiko Aritsuka, "FACTS & prototype custom power equipment for the enhancement of power transmission system performance & power quality".
- [8] N.G. Hingorani, "Introducing Custom Power," IEEE Spectrum, June 1999
- [9] M. Takeda, H. Yamamoto, T. Aritsuka, I. Kamiyama G.F. Reed, "Development of a Novel Hybrid Switch Device and Application to a Solid-State Transfer Switch," Proceedings of the IEEE PES Winter Power Meeting, New York, Jan./Feb. 1999, pp. 1151-1156.
- [10] M. Takeda, S. Murakami, A. Izuka, M. Hirakawa, M. Kishida, S. Hase, M. Mochinaga, "Development of SVG Series for Voltage Control Over Three-Phase Unbalance Caused by Railway Load," International Conf. on Power Electronics (IPEC), Yokohama, 1995.
- [11] G.F. Reed, M. Takeda, I. Iyoda, S. Murakami, T. Aritsuka, K. Tokuhara, "Improved Power Quality Solutions Using Advanced Solid-State Switching and Static Compensation Technologies," Proceedings of the IEEE PES Winter Power Meeting, New York, Jan./Feb. 1999, pp. 1132-1137.
- [12] J. Reason, "Solid-State Transfer Switch," Electrical World, Aug. 1996.
- [13] J.W. Schwartzenberg, R.W. DeDoncker, "15 kV Medium Voltage Static Transfer Switch," IEEE, May/June 1995.
- [14] N.J. Woodley, L. Morgan, A. Sundaram, "Experience with an Inverter-Based Dynamic Voltage Restorer" IEEE PES Transactions Paper PE-796- PWRD-0-06-1997.
- [15] O. Anaya-Lara, E. Acha, "Modeling and analysis of custom power systems by PSCAD/EMTDC," IEEE Trans. Power Delivery, vol. 17, no . I, pp. 266-272, January 2002.
- [16] S. Ravi Kumar, S. Sivanagaraju, "Simualgion of D-Statcom and DVR in power system," ARPN jornal of engineering and applied science, vol. 2, no. 3, pp. 7-13, June 2007.
- [17] A.E. Hammad, Comparing the Voltage source capability of Present and future Var Compensation Techniques in Transmission System, *IEEE Trans, on Power Delivery. Volume 1. No.1* Jan 1995.
- [18] G.Yalienkaya, M.H.J Bollen, P.A. Crossley, "Characterization of Voltage Sags in Industrial Distribution System", *IEEE transactions on industry applications, volume 34, No. 4, July/August*, PP.682- 688, 1999.