

## Mitigate Voltage Sag/Swell Condition and Power Quality Improvement in Distribution Line Using D-STATCOM

Pragti Jyotishi\*, Proff. Deeparamchandani\*\*

### Abstract

In this paper “Mitigate voltage sag/swell condition and power quality improvement in distribution line using D-STATCOM”. In power quality problems occur many types of disturbance in voltage, current or frequency failure in distribution networks, sensitive industrial loads. This paper shows the techniques of correcting the supply voltage sag, swell and interruption in a distributed system power electronics, based equipment called Distribution Static Compensator (D-STATCOM). A D-STATCOM injects a current into the system to correct the voltage sag, swell and interruption. Distribution STATCOM (D-STATCOM) exhibits high speed control of reactive power to provide voltage stabilization, protects distribution system from voltage sag and /or flicker caused by rapidly varying reactive current demand. During the transient conditions the D-STATCOM provides leading or lagging reactive power to active system stability, power factor correction and load balancing.

**Keywords:** Power quality, D-STATCOM, Voltage Sag, Voltage Source Converter (VSC), Energy storage system.

### I. INTRODUCTION

In recent years, there has been an increased emphasis and concern for the quality of power delivered to factories, commercial establishments and residences [1]. The most common problem in power quality today is voltage sag. Power engineers are increasingly concerned over the electrical power quality. Electrical power is perhaps the most essential raw material used by commerce and industry today. In a three phase system voltage sag by nature is three phase phenomena, which effect phase -to -phase voltages and phase-to-ground voltages both. Power-quality happens during fault condition, lightning strikes and other occurrences that adversely affect the line-voltage and/or current waveforms. The FACTS devices are introduced to electrical system to improve the power quality of the electrical power. Use of these FACTS controllers to enable corresponding power to flow through such line under normal and contingency conditions there are different type of FACTS device DVR, STATCOM, DSTATCOM, UPQC, UPFC, SVC, SSG, TCR, TSC, TSR, SSSC and etc. The reactive power at the terminals of the STATCOM depends on the amplitude of the voltage source. And these STATCOM in distribution system is called DSTACOM (Distribution-STACOM). Distribution-STATCOM (D-STATCOM) exhibits high speed and control reactive power, to give voltage stabilization flicker suppression [2]. A DSTATCOM is a controlled reactive source which includes a Voltage Source converter (VSC) and a DC link capacitor connected in shunt, capable of generating and /or absorbing reactive power [3]. FACTS applications represent a three-phase power rating from tens to hundreds of megawatts. Basically, FACTS

Controllers are based on an assembly of ac/dc and/or dc/ac converters and/or high power ac switches. D-STATCOM has been used to compensate reactive power and to prevent the voltage ‘flickers’ and improve power quality problem with the help of MATLAB SIMULINK software and used MATLAB version R 2010 A 7.10 / R 2010 B 7.11/ SIMULINK VERSION: 7.5.

### II. POWER QUALITY

#### 2.1 Overview:

Electric Power quality is a term which has captured increasing attention in power engineering in the recent years. The term power quality refers to maintaining a sinusoidal waveform of bus voltages at rated voltage and frequency. Power quality areas may be made according to the source of the problem such as converters, magnetic circuit non linearity by the wave shape of the signal such as harmonics, flicker or by the frequency spectrum (radio frequency interference). Power quality is simply the interaction of electrical power with electrical equipment. Power quality is the cause, and the ability of the electrical equipment to function in the power quality environment is the effect. Various sources use the term “power quality” with different meaning. It is used synonymously with “supply reliability,” “service quality,” “voltage quality,” “current quality,” “quality of supply” and “quality of consumption [13].

1. Low power quality problems Service entrance switchboard, lighting power distribution panel.
2. Moderate power quality problems HVAC power panels.

3. High power quality problems Panels supplying adjustable speed drives.

## 2.2 Power Quality Issues

Power quality problems have many names and descriptions. Surges, spikes, transients, blackouts, noise, voltage sag, voltage swell, interruption, dc offset are some common descriptions. In order to increase the reliability of a power distribution system, many methods of power quality problems have been following:

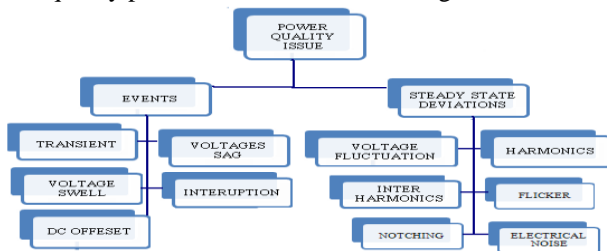

Figure 2.1 Power quality issues

### 2.2.1 Power Quality events

1. **Transients:** Transients, commonly called “surges” are sub-cycle disturbances of very short duration that vary greatly in magnitude.

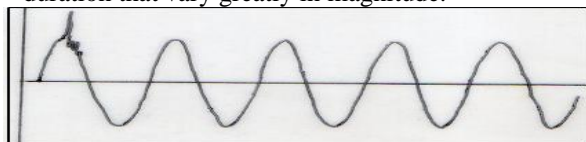

Figure 2.2 Transient event

2. **Voltage sag:** Sag is a reduction of AC voltage at a given frequency for the duration of 0.5cycles to 1 minute’s time.

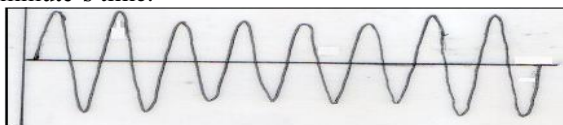

Figure 2.3 Voltage sag

3. **Voltage swells:** A voltage swell is an increase in the RMS voltage above the nominal voltage or a sliding reference voltage.

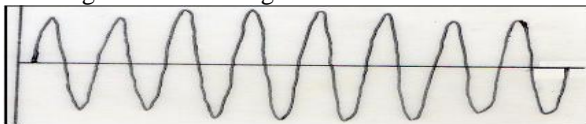

Figure 2.4 Voltage swell

4. **Interruptions:** An interruption is defined as a reduction in the supply voltages or load current to a level less than 0.1 p.u. for a time not more than 1 minute.

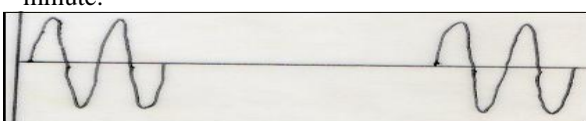

Figure 2.5 Interruption

5. **DC Offset:** Direct current (DC) can be induced into an AC distribution system, often due to failure

of rectifiers within the many AC to DC conversion technologies.

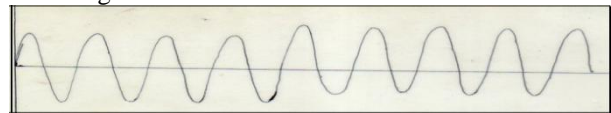

Figure 2.6 DC offset

### 2.2.2 Power quality steady state deviations

1. **Voltage fluctuation:** A voltage fluctuation is a systematic variation of the voltage waveform or a series of random voltage changes.

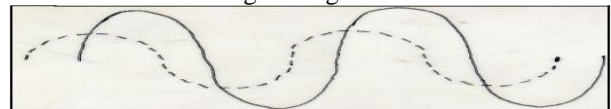

Figure 2.7 Voltage fluctuation

2. **Harmonic:** Harmonic distortion is the corruption of the fundamental sine wave at frequencies that are multiples of the fundamental voltage varies sinusoid ally at a specific frequency, usually 50 or 60 hertz.

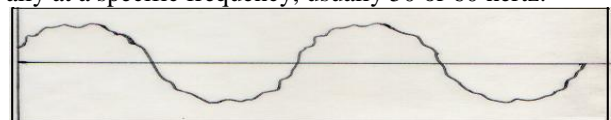

Figure 2.8 Harmonic distortion

**Odd and even order harmonics:** odd harmonics have odd numbers (e.g., 3, 5, 7, 9, 11), and even harmonics have even numbers (e.g., 2, 4, 6, 8, 10)

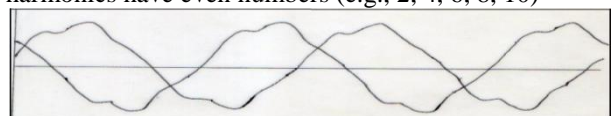

Figure 2.9 Odd & Even Harmonic

3. **Inter harmonic:** Inter harmonics are a type of waveform distortion that is usually the result of a signal imposed on the supply voltage by electrical equipment such as static frequency converters etc.

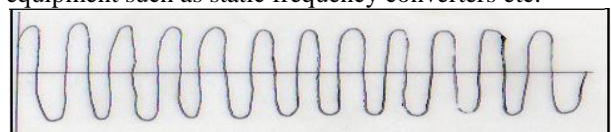

Figure 2.10 Inter Harmonic

4. **Notching:** Notching is a periodic voltage disturbance caused by electronic devices, such as variable speed drives and arc welders under normal operation.

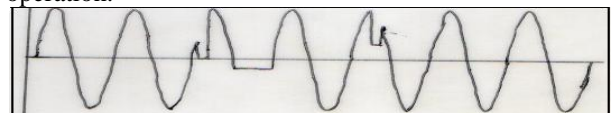

Figure 2.11 Notching

5. **Electrical noise:** Noise is unwanted on the power system voltage or current waveform. It is high frequency interference caused by a number of factors, including arc welding or the operation of some electrical motors.

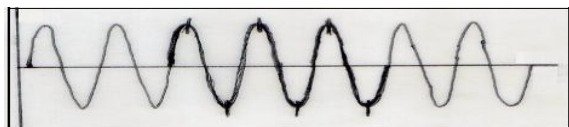

Figure 2.12 Electrical noise

### 2.3 Solution of Power Quality Problem

A power quality issue, especially, voltage problem is the vital concern in most distribution system today. The voltage problem is mainly from under-voltage (voltage sag) condition due to a short circuit or fault. Solving power quality problems depends on acquiring meaningful data at the optimum locations and within an expedient time frame.

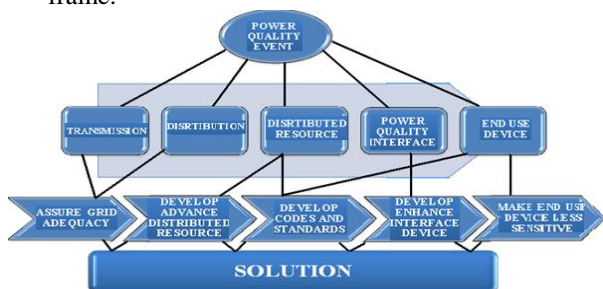

Figure: 2.13 Steps for power quality solutions

**1. Grounding & bonding integrity:** Grounding is a conducting connection by which an electrical circuit or equipment is connected to earth. Bonding is intentional electrical interconnecting of conductive paths in order to ensure common electrical potential between the bonded parts.

**2. Proper wiring:** An overall equipment inspection to ensure proper wiring within a facility. The entire electrical system should be checked for loose, missing or improper connections at panels, receptacles and equipment.

**3. Restoring technologies:** These restoring technologies are used to electrical loads to improve the power quality problem. For example: Voltage sag, Transients, Frequency variation, Spikes, Interruption.

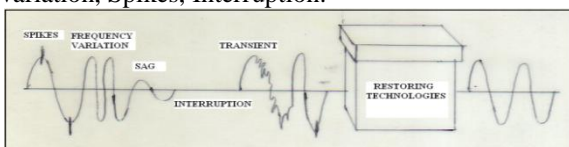

Figure: 2.14 Restoring technologies

**4. Distributed generation:** Distributed Generation units can be used to provide clean power to critical loads, isolating them from disturbances with origin in the grid.

**5. Harmonic filters:** Nonlinear loads produce harmonic currents that can ensure that harmonic currents produced by a nonlinear current source will not unduly interfere with the rest of the power [4].

### 2.3.1 Role of facts device

A flexible alternating current transmission system (FACTS) is a system composed of static equipment used for the AC transmission of electrical energy. It is generally a power electronics-based system [5]. These devices are capable of mitigating multiple PQ problems which is applicable to distribution systems to provide power quality solutions.

#### 1. Static synchronous compensator (STATCOM):

A “Static synchronous compensator (STATCOM) is a regulating device used on alternating current electricity transmission networks. STATCOM based on a voltage-sourced converter and a current-sourced converter.

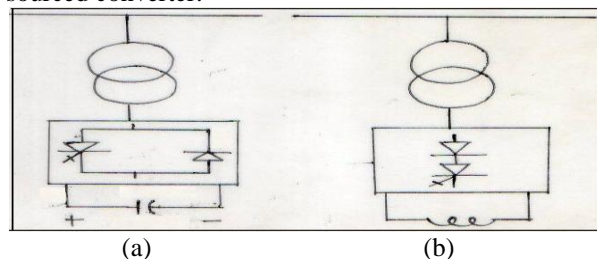

Figure: 2.15 (a) STATCOM based on a Voltage source Converters. (b) STATCOM based on a Current source Converters.

**2. Static var compensator (SVC):** The SVC is an impedance matching device, designed to bring the system closer to unity power factor. A combination of different static and mechanically-switched var compensators whose outputs are coordinated.

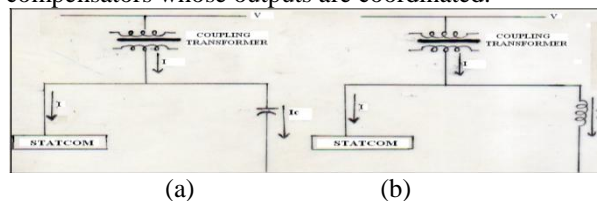

Figure: 2.16 (a) Static Var Compensator with capacitor. (b) Static Var Compensator with inductor.

**3. Dynamic voltage restorer (DVR):** Dynamic voltage restorer (DVR) can provide the variety of transmission and distribution systems solution to mitigate voltage sag it is recently being used as the active solution for voltage sag mitigation by and establishing the voltage quality. It's a series compensation device, which protects sensitive electric load from power quality problems such as voltage sags, voltage swells, interruption and use voltage source converters (VSC).

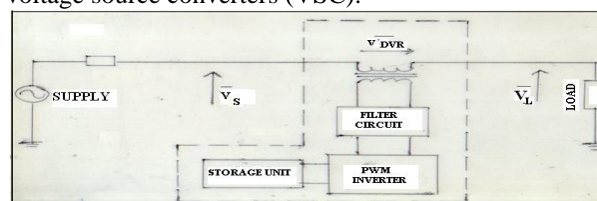

Figure: 2.17 Dynamic voltage restorer

**4. Static synchronous series compensator (SSSC):** SSSC is a solid-state voltage source inverter, injects an almost sinusoidal voltage, of variable magnitude in series with the transmission line. The injected voltage is almost in quadrature with the line current.

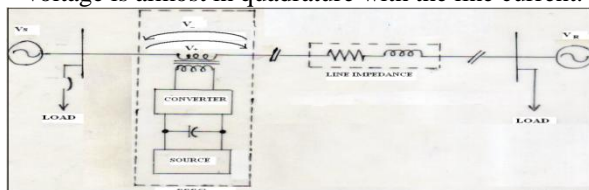

Figure: 2.18 Static synchronous series compensator

**5. Unified power flow controller (UPFC):** It is the only device with series and parallel compensation operated by a common link of direct current. The series compensator has a three-phase inverter and voltage source (series converter). A UPFC system can regulate the active and reactive power at the same time.

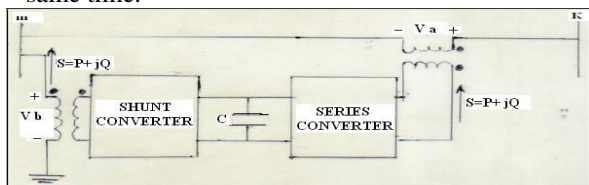

Figure: 2.19 Unified power flow controller

### III. METHODOLOGY

#### 3.1 Distribution Static Compensator (D-STATCOM)

D-STATCOM is the most important controller for distribution networks. It has widely used to regulate system voltage, improve voltage profile, reduce voltage harmonics, reduce transient voltage disturbances and load compensation. The D-STATCOM uses a power-electronics converter is controlled using pulse width modulation (PWM). The designed D-STATCOM is connected in shunt to the 11 kV test distribution system [6]. It can exchange both active and reactive power with the distribution system.

#### 3.2 Basic Principal and Connection of D-STATCOM

A single line diagram has shown in (figure 3.1) (D-STATCOM) static compensator. In this single line diagram are connected in a step-up transformer, and a controller this D-STATCOM consists of self-commutated converters using Gate Turn off (GTO) Thyristors, a dc voltage source.

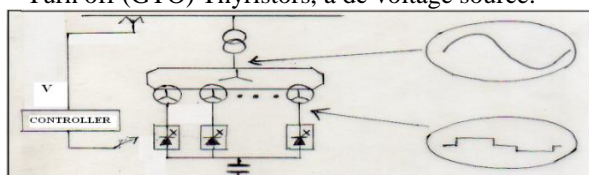

Figure: 3.1 Single Line diagram of D-STATCOM.

The Distribution Static Compensator (D-STATCOM) is a voltage source inverter based static

compensator that is used for the correction of bus voltage sags.

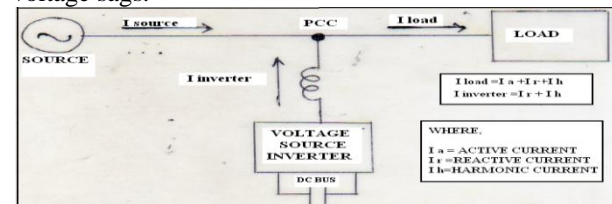

Figure: 3.2 Basic structure of D-STATCOM

The major components of a D-STATCOM are shown in Fig.3.2. It consists of a source, DC link capacitor, one or more inverter modules, an ac filter, a transformer to match the inverter output to the line voltage, and a PWM control strategy [7].

#### Equation Related D-STATCOM:

The shunt injected current  $I_{sh}$  corrects the voltage sag by adjusting the voltage drop across the system impedance  $Z_{th}$ . The value of  $I_{sh}$  can be controlled by adjusting the output voltage of the converter. The shunt injected current  $I_{sh}$  can be written as,

$$I_{sh} = I_L - I_S \quad (3.1)$$

$$I_L - I_S = I_L - \left\{ \frac{(V_{th} - V_L)}{Z_{th}} \right\} \quad (3.2)$$

$$I_{sh} \angle \eta = I_L \angle -\theta - \frac{V_{th}}{Z_{th}} \angle (\delta - \beta) + \frac{V_L}{Z_{th}} \angle (-\beta) \quad (3.3)$$

The complex power injection of the D-STATCOM can be expressed as,

$$S_{sh} = V_L I_{sh}^* \quad (3.4)$$

Where,

$I_{out}$  = Output current,  $I_L$  = Load current,  $I_S$  = Source current,  $V_{Th}$  = Thevenin voltage,  $V_L$  = Load voltage,  $Z_{Th}$  = Impedance ( $Z_{Th} = R + j X$ )

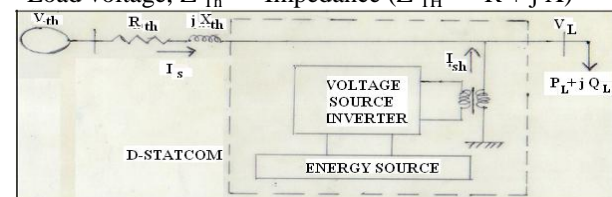

Figure: 3.3 Basic circuit diagram of D-STATCOM.

It may be mentioned (Figure 3.3) that the effectiveness of the D-STATCOM in correcting voltage sag depends on the value of  $Z_{th}$  or fault level of the load bus. When the shunt injected current  $I_{sh}$  is kept in quadrature with  $V_L$ , the desired voltage correction can be achieved without injecting any active power into the system when the value of  $I_{sh}$  is minimized.

A (Figure 3.4) shows D-STATCOM connection is based on an input current  $I_S$  is equal to the sum of  $I_C$  and  $I_L$  and a simple two-level VSC

which is controlled using conventional sinusoidal pulse width modulation (PWM) [8].

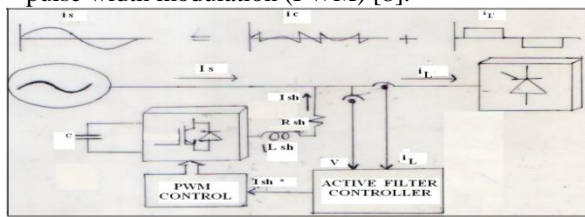

Figure: 3.4 System connection of DSTATCOM.

### 3.3. Basic Configuration and Operating of D-STATCOM

The D-STATCOM employs an inverter to convert the DC link voltages  $V_{dc}$  on the capacitor to a voltages source of adjustable magnitude and phase. In (Figure 3.5) the D-STATCOM is shows that the construction controller of the D-STATCOM is used to operate the inverter in such a way that the phase angle between the line voltage and the inverter voltage is accurately adjusted so that the D-STATCOM generates or absorbs the desired VAR at the point of connection [14].

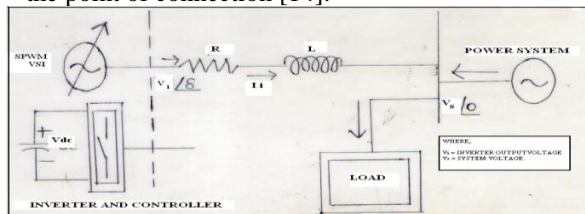
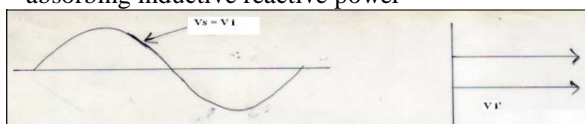
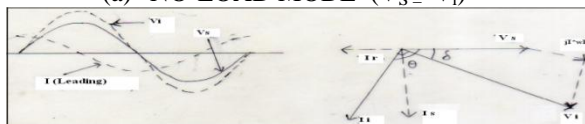

Figure: 3.5 Basic building blocks of the D-STATCOM

The phase of the thyristor-based inverter,  $V_i$  is controlled in the same way as the distribution system voltage,  $V_s$  (Figure 3.6) shows the three basic operation modes of the D-STATCOM output current,  $I$ , which varies depending upon  $V_i$ . [Fig. (a)] shows, If  $V_i$  is equal to  $V_s$ , the reactive power is zero and the D-STATCOM does not generate and absorb reactive power. [Fig. (b)] shows, When  $V_i$  is greater than  $V_s$ , the D-STATCOM shows an inductive reactance connected at its terminal. The current  $I$  flows through the transformer reactance from the D-STATCOM to the ac system, and the device generates capacitive reactive power. [Fig. (c)] shows, If  $V_s$  is greater than  $V_i$ , the D-STATCOM shows the system as a capacitive reactance. Then the current flows from the ac system to the D-STATCOM resulting in the device absorbing inductive reactive power



(a) NO-LOAD MODE ( $V_s = V_i$ )



(b) CAPACITIVE MODE ( $V_i > V_s$ )

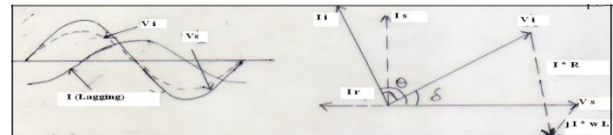

(c) INDUCTIVE MODE ( $V_i < V_s$ )

Figure: 3.6 Operation modes of D-STATCOM

### 3.4. Voltages Source Converter

Three phases Voltage Source Converter (VSC) is heart of most new FACTS power equipments. Voltage source converters (VSC) are commonly used to transfer power between a dc system and an ac system or back to back connection for ac systems with different frequencies. A basic VSC structure is shown in (Figure.3.7) where  $R_s$  and  $L_s$  represent the resistance and inductance between the converter ac voltages  $V_c$  and the ac system voltage  $V_s$  and  $I_s$  the current injected into the grid. A dc capacitor is connected on the dc side to produce a smooth dc voltage. The IGBTs are connected anti parallel with diodes for commutation purposes and charging of the DC capacitor [10] [12].

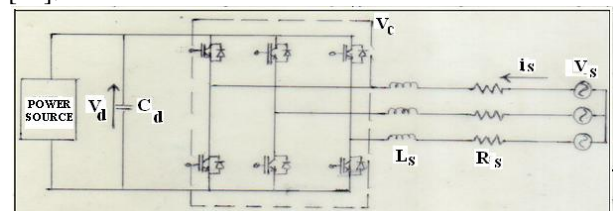

Figure: 3.7 Voltages source converter (VSC)

### 3.5. D-STATCOM Controllers

**1. Proportional integral (pi) controller:** The proportional and Integral (PI) controllers were developed because of the desirable property that systems with open loop transfer functions of type 1 or above have zero steady state error with respect to a step input it terms is important to increase the speed of the response and also to eliminate the steady state error adjusting the process control inputs.

**Proportional Action:** Responds quickly to changes in error deviation.

**Integral Action:** Is slower but removes offsets between the plants output and the reference.

**The PI regulator is:**

$$\frac{U(s)}{E(s)} = Kp + K1/s \quad (3.5)$$

$$\frac{U(s)}{E(s)} = -\frac{\frac{1}{sC1} + R2}{R1} \quad (3.6)$$

$$\frac{U(s)}{E(s)} = -\left\{ \frac{R1}{R2} + \frac{1}{sC1R1} \right\} \quad (3.7)$$

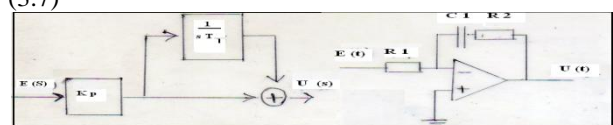

Figure: 3.8 Proportional Integral (PI) Controller

#### IV. D-STATCOM MODELING USING THE SIMULINK POWER SYSTEM BLOCK

The control system only measures the rms voltage at the load point i.e., no reactive power measurements are required. The VSC switching strategy is based on sinusoidal PWM technique which offers simplicity and good response shown (figure 4.1). The PI controller process identifies the error signal and generates the required angle  $\delta$  to drive the error to zero, i.e. the load rms voltage is brought back to the reference voltage. The main parameters of the sinusoidal PWM scheme are the

amplitude modulation index  $M_a$  of signal control and the frequency modulation index  $M_f$  of the triangular signal [9].

The amplitude index  $M_a$  is kept fixed at 1 pu.

$$M_a = V_{\text{control}} / V_{\text{tri}}$$

The frequency of modulation index is given by,

$$M_f = F_s / F_f$$

Where,

$V_{\text{control}}$  = Peak amplitude of the signal.

$V_{\text{tri}}$  = Peak amplitude of the Triangular signal.

$M_f$  = Frequency of modulation index.

$F_s$  = Switching frequency.

$F_f$  = Fundamental frequency

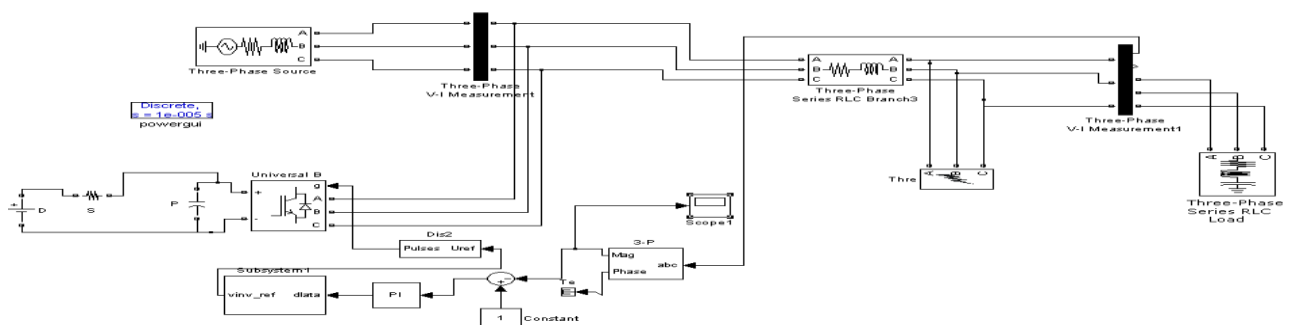

Figure: 4.1 D-STATCOM connect in distribution line reduced three phase fault implemented with MATLAB/SIMULINK.

#### 4.1. D-STATCOM Simulations and Results for Voltage Sag

##### 4.1.1 Performance of voltage $v_{\text{rms}}$ at load point, with three-phase-to-ground fault:

##### (A) CASE1. Three phase- to-ground fault without D-STATCOM

In the first case simulation contains no D-STATCOM and a three phase-to-ground fault is applied at point A, via a fault resistance 0.20  $\Omega$ , Ground Resistance 0.001. The fault is created for the duration of 0.3seconds to 0.5seconds. The output wave for the load without D-STATCOM shown in figure 4.2.

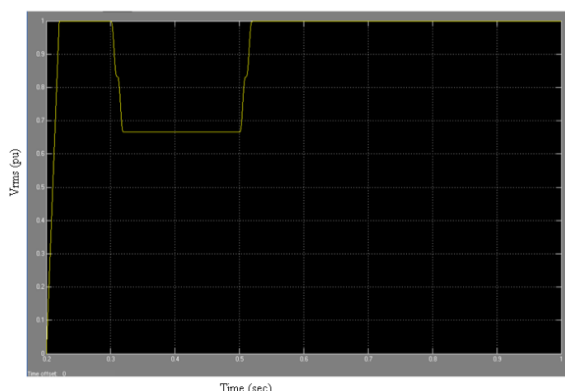

Figure: 4.2 Output Response of the distribution line without D-STATCOM

##### (B) CASE2. Three phase-to- ground fault with D-STATCOM

The second simulation is carried out using the same scenario DSTATCOM is connected to the system, then the voltage sag is mitigated almost completely .The output wave for the load with D-STATCOM shown in figure4.3

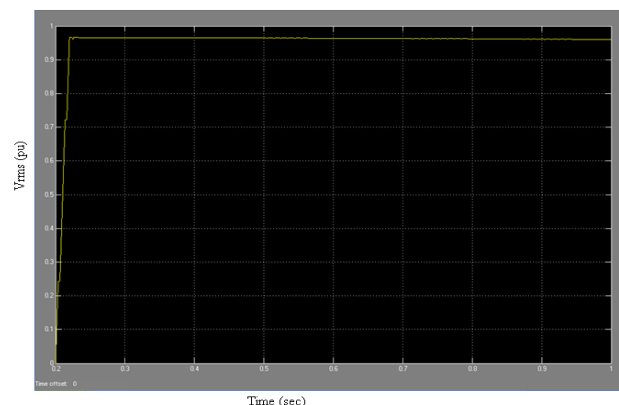

Figure: 4.3. Output Response of the Distribution line with D-STATCOM

##### 4.1.2 Performance of voltage $v_{\text{rms}}$ at load point, with three phase-to-ground fault:

##### (A) CASE1. Three phase ground fault without D-STATCOM

In the first case simulation contains no D-STATCOM and a three phase-to-ground fault is applied at point A, via a fault resistance 0.40  $\Omega$ , Ground Resistance 0.001. The fault is created for the duration of 0.3seconds to 0.5seconds. The output

wave for the load without D-STATCOM shown in figure 4.4.

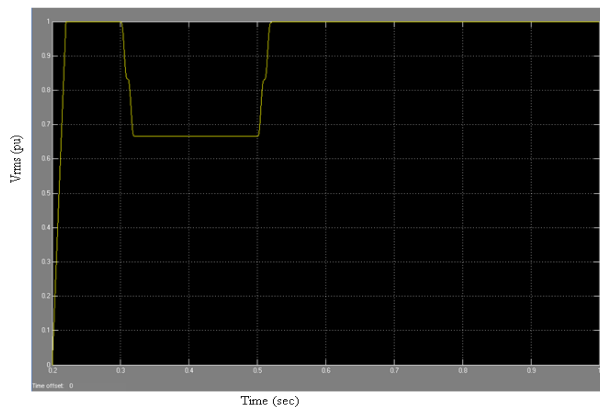

Figure: 4.4. Output Response of the Distribution line without D-STATCOM

#### (B) CASE2. Three phase-to-ground fault with D-STATCOM

The second simulation is carried out using the same scenario DSTATCOM is connected to the system, then the voltage sag is mitigated almost completely. The output wave for the load with D-STATCOM shown in figure 4.5.

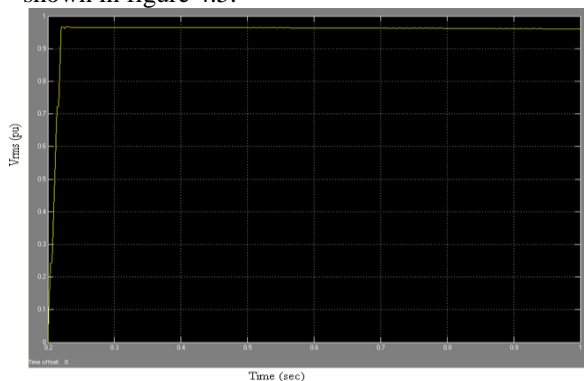

Figure: 4.5. Output response of the line with D-STATCOM

### V. CONCLUSION

In this work, the investigation on the role of Distribution Static Synchronous Compensator (DSTATCOM) can compensate the voltage sag and swells conditions. In order to achieve improved power quality levels simulated with or without DSTATCOM connected to the distribution system. The Simulation results show that the DSTATCOM can compensate the voltage sag and swell conditions. In this thesis work, mitigate Voltage Sag condition and Power Quality improvement on 25 % in fault resistance 0.20  $\Omega$  with DSTATCOM and in fault resistance 0.40  $\Omega$  mitigate Voltage Sag condition and Power Quality improvement on 30 % with DSTATCOM. It can be concluded that DSTATCOM improves the power quality and remove the voltage sag condition in distribution network.

### REFERENCES

- [1] Manoj nair "Power quality" text book balaji learning published Edition: 11 is bn no. 978-81-910618-6-4.
- [2] C8-12,"DSTATCOM (Distribution Static Compensator)", 24/08/2007 VIGO (Spain).
- [3] N.G. Hingorani and L. Gyugyi, "Understanding FACTS: Concepts and Technology of Flexible AC Transmission Systems", 1st edition, The Institute of Electrical and Electronics Engineers, 2000.
- [4] B. K. Prusty & S. M. Ali. "Power quality issue and its parameters measurement technique with improvement feature in a distribution system." ISSN (Print) : 2319 – 2526, Volume-2, Issue-1, 2013.
- [5] Dr. S.M. Ali B.K.Prusty M.K.Dash S. P. Mishra. "Role of facts devices in improving power quality in a grid connected renewable energy system." Journal of Engineering Research and Studies E-ISSN0976-7916.
- [6] Hendri Masdi, Norman Mariun Senior MIEEEE, S.M.Bashi MIEEEE, A. Mohamed Senior MIEEEE,Sallehudin Yusuf MIEEEE "design of a prototype d-statcom for voltage sag mitigation."
- [7] Veeraiah Kumbha, N. Sumathi "Power quality improvement of Distribution lines using DSTATCOM under various loading conditions." International Journal of Modern Engineering Research (IJMER) www.ijmer.com Vol. 2, Issue. 5, Sep.-Oct. 2012 pp-3451-3457 ISSN: 2249-6645.
- [8] Ch. Siva Koti Reddy, Dr. P.Linga Reddy. "A DSTATCOM-Control Scheme for Power Quality Improvement of Grid Connected Wind Energy System for Balanced and Unbalanced Non linear Loads." International Journal of Modern Engineering Research (IJMER) www.ijmer.com Vol.2, Issue.3, May-June 2012 pp-661-666 ISSN: 2249-6645.
- [9] Ravilla Madhusudan,Ramamohan Rao "Modeling and simulation of a Distribution STATCOM (DSTATCOM) for power quality problems voltage sag and swell Based on sinusoidal pulse width modulation (SPWM)".IEEE-International conference on advances in engineering ,science and management (ICAESM-2012)March 30,31,2012.ISBN: 978-81-909042-2-3©2012 IEEE.
- [10] Dr. Alka Singh, Dr. Bhim Singh. "An application of iterative learning control applied to distribution static compensator system." ITM Gurgaon, IIT Delhi.
- [11] Irena Wasiak, Rozmyslaw Mienski, Ryszard Pawelek, Piotr Gburczy. "Application of DSTATCOM

- compensators for mitigation of power quality disturbances in low voltage grid with distributed generation.”9th International Conference Electrical Power Quality and Utilisation Barcelona 9-11 October 2007.
- [12] Pradeep Kumar, Niranjan Kumar & A.K.Akella. “Review of D-STATCOM for Stability Analysis.”IOSR Journal of Electrical and Electronics Engineering (IOSRJEEE), ISSN: 2278-1676 Volume 1, Issue 2 (May-June 2012), PP 01-09.
- [13] Dr. S.M. Ali B.K.Prusty M.K.Dash S. P. Mishra. “Role of facts devices in improving power quality in a grid connected renewable energy system.” Journal of Engineering Research and Studies E-ISSN0976-7916.
- [14] S.Sundeeep, Dr. G. MadhusudhanaRao “Modelling and Analysis of Custom Power Devices for Improve Power Quality” International Journal of Electrical and Computer Engineering (IJECE) Vol.1, No.1, September 2011, pp. 43~48 ISSN: 2088-8708.
- [15] Pull venkata kishore, S.Rama reddy and P.V.Kishore. “Modelling and simulation of 14 bus system with D-STATCOM for power quality improvement.” Indian J.Sci.Res.3 (1): 73-79, 2012.
- [16] P.Suman Pramod Kumar, N.Vijaysimha, C.B.Saravanan. “Static synchronous series compensator for series compensation of ehv transmission line.”International Journal of Advanced Research in Electrical, Electronics and Instrumentation Engineering Vol. 2, Issue 7, July 2013 ISSN (Print): 2320 – 3765 ISSN (Online): 2278 – 8875.
- [17] Hariyani Mehul p “Voltage stability with the help of D-STATCOM.” National Conference on Recent Trends in Engineering & Technology 13-14 May 2011 B.V.M. Engineering College, V.V.Nagar, and Gujarat, India.
- [18] Yueqiu Wang, Jie Tang, Xionger Qiu “Analysis and Control of D-STATCOM under unbalanced voltage condition” 2011 International Conference on Mechatronic Science, Electric Engineering and Computer August 19-22, 2011, Jilin, China.
- [19] S. Elango Dr. E.Chandra Sekaran “Mitigation of voltage sag using Distribution Static Compensator (D-Statcom).” 978-1-61284-764-1/11/\$26.00 ©2011 IEEE.
- [20] Sambugari Anil Kumar, D. vanurrappa “Voltage Dip mitigation in Distribution System by Using DStatcom” Journal of Energy Technologies and Policy www.iiste.org ISSN 2224-3232 (Paper) ISSN 2225-0573 (Online) Vol.1, No.1, 2011.