

Performance Analysis of Beacon Enabled IEEE 802.15.4 Using GTS in Zigbee

Abhinav Singh¹, Pankaj Kumar Patel², P.C.Jain³

School Of Electronics Centre For Development Of Advanced Computing Noida, India

Abstract—The current IEEE 802.15.4 standard restricts the beacon enabled approach to star networks, while they support multi-hop networking in mesh but with no synchronization. In this paper there is proposal of a distributed IEEE802.15.4 MAC modification to improve GTS usability in cluster networks. Location of BOP in inactive period with Virtual GTS is proposed and throughput is observed for chain topology.

Keywords- GTS, Beacon Only Period(BOP), MAC,PNC

I. INTRODUCTION

The IEEE 802.15.4 [1] MAC protocol supports two operational modes: the beaconless mode, in which nodes stay active all the time, and the beacon mode, in which beacon frames are periodically sent by coordinators to synchronize sensor nodes. The advantage of this synchronization scheme is that all nodes can wake up and sleep at the same time allowing very low duty cycles and hence save energy. In addition, when the beacon mode is used, nodes can use Guaranteed Time Slots specifically designed to fulfil application's QoS requirements but due to beacon frame collision beacon mode is limited.

There can be up to three types of periods in a superframe: the contention access period (CAP), the contention-free period (CFP), and the inactive period .The combination of CAP and CFP is known as the *active period*. The active period is divided into 16 equal time slots. The beacon frame always starts at the beginning of first time slot. There can be up to seven GTSs in CFP. Each GTS can occupy one or more time slots. A superframe may optionally have an inactive period.

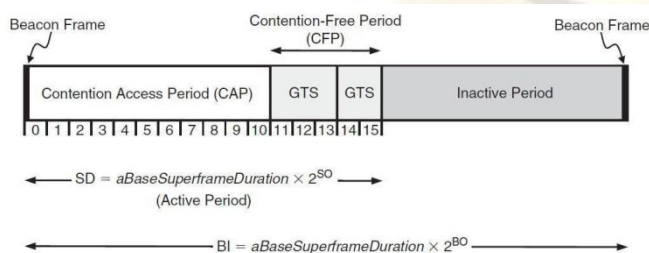

Fig.1 Superframe Structure

The Beacon-Only-Period [2] approach is one of the proposals suggested to remedy the beacon collision problem in 802.15.4/Zigbee cluster-tree topology. It was proposed for the discussion at the IEEE 802.15.4b Study Group as a response to the call for proposal of IEEE 802.15.4b, MAC Enhancement. This proposal introduces a new mechanism at the MAC layer to avoid beacon collisions. It is based on a new Super frame structure. The new structure will start with a period reserved to beacon frame transmissions. During this period, each coordinator will have a Contention-Free Time Slot to send his beacon frame.

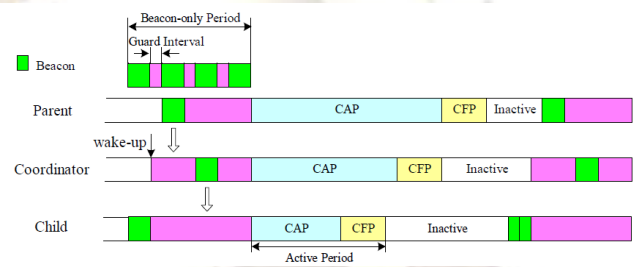

Fig.2 Beacon Only Period

II. RELATED WORK

A. Beacon Scheduling

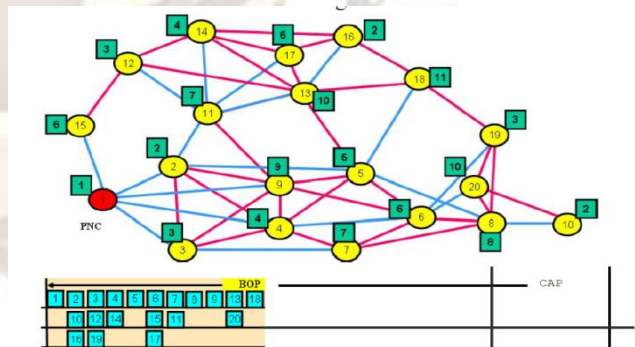

Fig.3 Beacon scheduled network

Every node sends beacon with beacon payload [3] containing its depth information and Beacon Transmission Time Slot of node and its neighbors and neighbor's neighbor. The beacon scheduling is performed by choosing the smallest

time slot of the BOP slots which avoids the time slots occupied by neighbors and its neighbor's neighbor.

B. GTS Blockage Problem

The problem [2] with BOP based approach and the use of the GTS lies in the fact that since nodes share the same super-frame duration, once a node occupies a GTS, its neighbors and neighbor's neighbor cannot reuse it to avoid collisions.

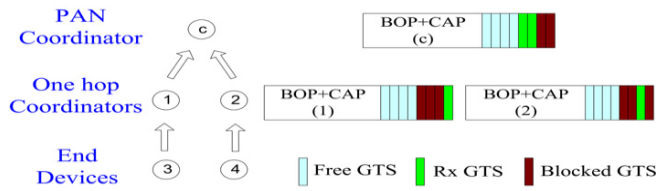

Fig.4 GTS blockage problem

C. Efficiency Problem

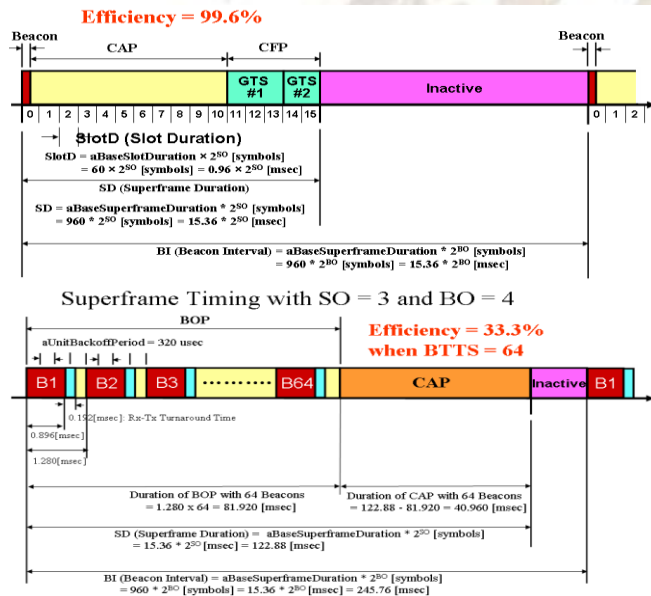

Fig.5 Efficiency problem in BOP

Above figure [6] shows that efficiency is decreased to 33.3% from 99.6% if beacon only period is added.

D. Concept of Virtual GTS

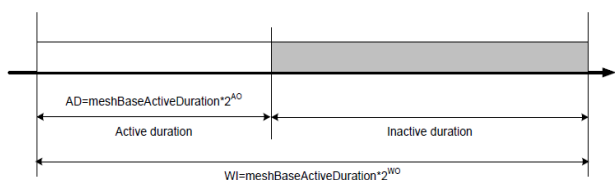

Fig.6 Time structure of IEEE 802.15.5

To remove GTS blockage problem introduction of time slots are needed in inactive period. Time structure in

IEEE 802.15.5 [8] is similar to superframe structure. The reservation based method first completes reservation by transmitting a reservation request frame for data transmission in the active duration and then actually transmits data at the reserved time slot in the inactive duration.

With the design shown in Fig.8, each node has a different set of VCFP [2] within its two hop neighbourhood so data frame collisions are avoided. The term virtual is used because the coordinator does not need to stay active in the VGTS if the slot is not allocated to any node which in turn saves energy.

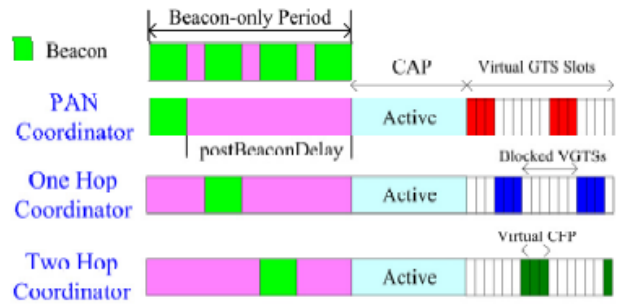

Fig.7 Virtual GTS

E. Location Of BOP

The size of the BOP [4] may become too large as the network grows having many nodes, and thus the efficiency in data communication can be very low. Beacon of all the nodes except PNC can be moved to inactive period as shown in Fig.9.

BOP Position Change for Legacy Devices-

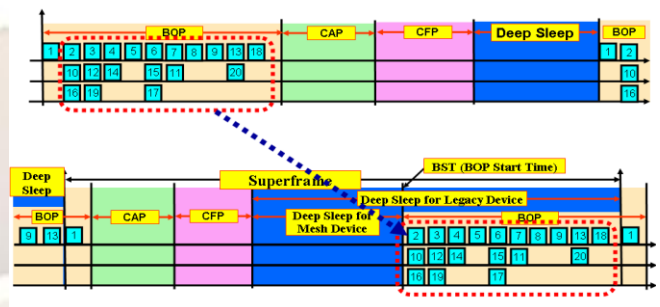

Fig.8 Location of BOP in inactive period

III. PROPOSAL OF VGTS AND BOP IN CHAIN TOPOLOGY

Chain topology is a special case of cluster tree network. All the nodes are connected in a chain fashion. In the Fig.9 ten nodes are shown connected in chain topology. PNC is marked as P and shown in red color. All the nodes except the last node marked as A are FFD. Node marked as A is RFD. Data transmission is from node A to PNC through VGTS. Superframe structure is modified as shown in Fig.10 in which BOP is located in inactive period. Superframe

duration is modified and in proposed scheme VGTS a part of inactive period is added to superframe duration. So, new superframe duration can be defined as:

$$aBaseSuperframeDuration \times 2^{SO} + VGTS \text{ Period} \quad (1)$$

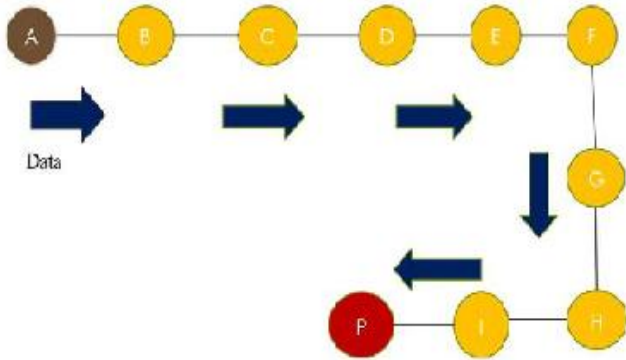

Fig.9 Chain topology showing data transfer from A to P

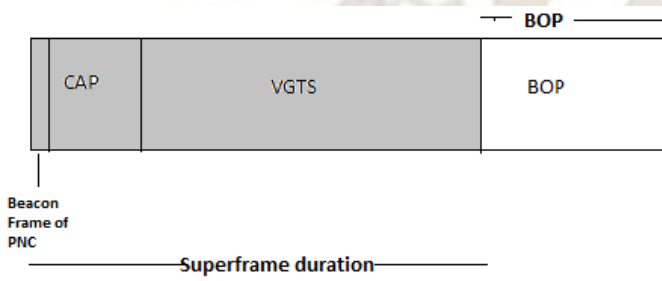
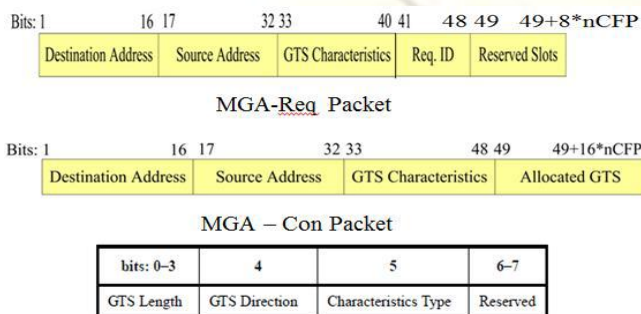

Fig.10 Modified Superframe structure

VGTS in our new superframe structure is the period containing data slots. CAP is used for GTS allocation requests and confirm. PNC sends beacon frame in the superframe duration and rest all nodes send beacon frame in the inactive period which is named as BOP in our modified superframe duration. First beacon frame will be sent by PNC. After that all remaining nodes send their beacon frames in BOP and then reserve slots of VGTS as shown in Fig.12&13. Node A requests for reservation slot from PAN Coordinator through intermediate nodes by reservation request frame i.e. MGA-Req Packet in CAP.



GTS Characteristic Field
 Fig.11 Request and confirm packet

GTS Allocation Request is received by the PAN Coordinator through intermediate nodes and responds by allocating the VGTS, the period defined in new superframe structure by sending MGA-Con Packet. As the MGA-Con packet passes through nodes it allocates the slot as shown in Fig.12. At the last Mesh GTS Allocation Confirm packet reaches A and allocates a slot of VGTS.

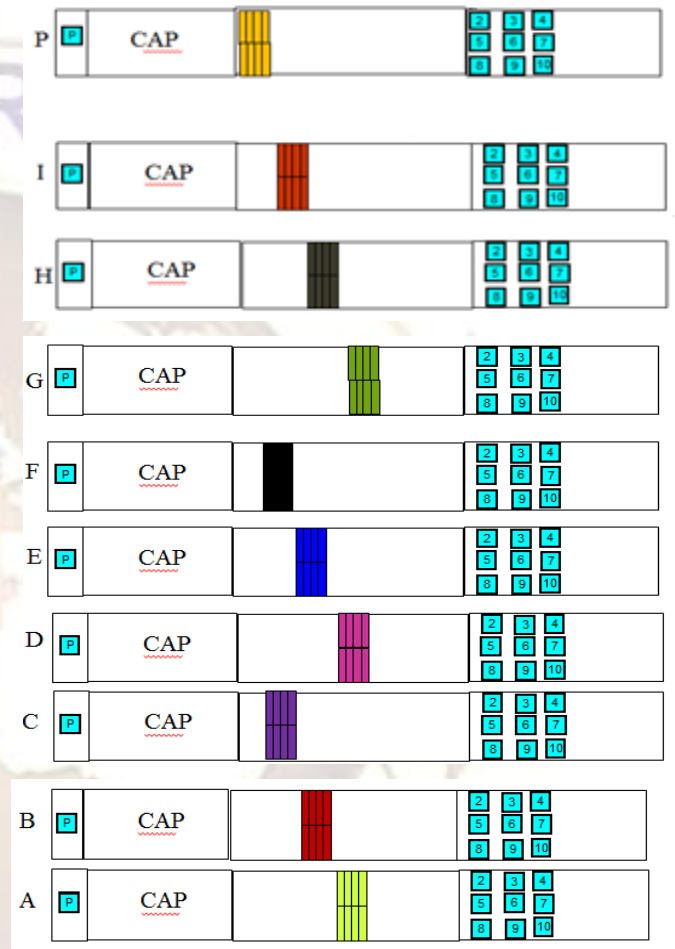

Fig.12 Allocation of GTS/VGTS and scheduled BOP

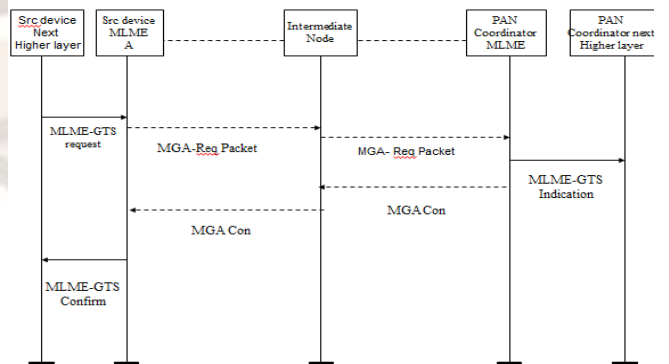

Fig.13 GTS allocation request

IV. EVALUATION AND RESULTS

A node that has been [5] allocated a VGTS can transmit a message if and only if the whole transaction, including data transmission, the Intra-Frame Spacing (IFS), can be completed before the end of the GTS. Otherwise, it must wait until the next GTS. Parameters defined in our proposal are given in Table I.

TABLE I
PARAMETERS

Parameters	Values
SIFS	48 bits
LIFS	160 bits
Beacon Frame Time	0.896 msec
Rx-Tx Turnaround Time	0.192 msec
aMaxPHYPacketSize	1016 bits
aUnitBackoff Period	0.320 msec
aBaseSuperframeDuration	15.36 msec
aMaxSIFSFrameSize	144 bits
aMinCAPLength	7.04 msec
SO	3
BO	5

For our proposed scheme we took 5Kbps data rate and 10 Micaz nodes. SoC used for our proposal analysis is XbeePro with development kit CC2520, Iwise-msp430f2618 and TELOS-B-msp430f1611.

Equations from network calculus are used for analytical results and throughput is calculated at each and every node. Throughputs at some of the nodes are given in Table II.

TABLE II
THROUGHPUT AT SOME NODES

Node	Throughput
2	1.158 Kbps
4	0.0168Kbps
6	0.00329 Kbps
8	0.000176 Kbps
10	0.00000939 Kbps

As the number of nodes increases throughput of the network decreases and for very large network throughput becomes negligible. Calculation for throughput is done considering long frames and the neglecting time for GTS allocation request and GTS confirm request.

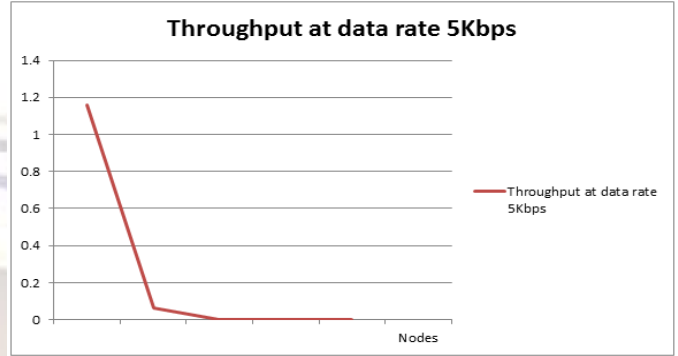

Fig.14 Throughput curve

Curve obtained after throughput analysis shows that using GTS approach in chain topology gives very low throughput. Bar diagram in Fig. 15 shows the efficiency for our proposed scheme.



Fig. 15 Efficiency bar diagram

As the number of nodes increases efficiency for BOP located in active period decreases whereas efficiency for BOP located in inactive period remains constant.

V. CONCLUSION

The scheme proposed in this approach provides a convenient way to use GTS in multihop. It also removes the limitations of GTS but shows that a very low throughput is achieved when GTS is used in chain topology. Efficiency can be made constant by changing the position.

REFERENCES

[1] IEEE 802.15.4 Wireless LAN Medium Access Control (MAC) and Physical Layer (PHY) specifications for Low-Rate Wireless Personal Area Networks (LR-WPANs), 2006.

- [2] Berta Carballido, Susan Rea, Dirk Pesch, "Guaranteeing Reliable Communications in Mesh Beacon-Enabled IEEE802.15.4 WSN for Industrial Monitoring Applications", The Second International Conference on Ad Hoc Networks (AdHocNets10), Victoria, British Columbia, Canada, August, 2010
- [3] H. Jeon and Y. Kim, "BOP (Beacon-Only Period) and Beacon Scheduling for MEU (Mesh- Enabled USN) Devices," The 9th International Conference on Advanced Communication Technology, vol. 2, pp. 1139-1142, February 2007.
- [4] H.-I. Jeon, Y. Kim, "BOP Location Considerations and Beacons Scheduling for Backward Compatibility to Legacy IEEE 802.15.4 Devices", TG 5, July 2006.
- [5] Anis KOUBAA, Mário ALVES, Eduardo TOVAR, "GTS Allocation Analysis in IEEE 802.15.4 for Real-Time Wireless Sensor Networks". 20th International Conference on Parallel and Distributed Processing Symposium, pp. 8, April 2006.
- [6] Ho-In Jeon and Yeonsoo Kim, "An Analysis of 802.15.4-Based Mesh Network Architecture", TG5, May 2006.
- [7] IEEE 802.15.5 Mesh Topology Capability in Wireless Personal Area Networks (WPANs). 2009.

